

Company: San Diego Gas & Electric Company (U 902 M)
Proceeding: 2024 General Rate Case
Application: A.22-05-XXX
Exhibit: SDGE-08-WP-S

PUBLIC

**SUPPLEMENTAL WORKPAPERS TO
PREPARED DIRECT TESTIMONY
OF NORM G. KOHLS
(PIPELINE SAFETY ENHANCEMENT PLAN)
ON BEHALF SAN DIEGO GAS AND ELECTRIC COMPANY
VOLUME I of II**

**BEFORE THE PUBLIC UTILITIES COMMISSION
OF THE STATE OF CALIFORNIA**

MAY 2022



TABLE OF CONTENTS

VOLUME	WORKPAPER CHAPTER TITLE	PAGE NO.
I.	Introduction to Workpapers Supporting the Testimony of Norm Kohls	WP-1 – 19
	SDG&E Reasonableness Review Pipeline Project Workpapers	WP-20 – 197
	SDG&E Reasonableness Review Valve Enhancement Project Workpapers	WP-198 – 301
II.	<i>Appendix A</i> – Summary of Standard Planning and Construction Practices for Replacement, Hydrotest, Valve, and Abandonment Projects	WP-A1 – A26
	<i>Appendix B</i> – Glossary of Terms	WP-B1 – B14

VOLUME I

WP-1 – 19

Introduction to Workpapers Supporting the Testimony of Norm Kohls

WP-20 – 197

SDG&E Reasonableness Review Pipeline Project Workpapers

WP-198 – 301

SDG&E Reasonableness Review Valve Project Workpapers

WP-1 – 19

Introduction to Workpapers Supporting the Testimony of Norm Kohls

I. INTRODUCTION

In D.14-06-017 the California Public Utility Commission (CPUC) approved SoCalGas and SDG&E's plan to execute hundreds of unique and discrete in-service pressure test, replacement, abandonment, and valve enhancement projects as soon as practicable as part of the Pipeline Safety Enhancement Plan (PSEP)¹. This Decision also adopted a process for reviewing and approving PSEP implementation costs after-the-fact and established balancing accounts to record PSEP expenditures². To recover PSEP costs, SDG&E was ordered to "file an application with testimony and work papers to demonstrate the reasonableness of the costs incurred which would justify rate recovery."³ In D.16-08-003, the CPUC modified this decision and directed SDG&E to submit two standalone reasonableness review applications for PSEP⁴ and, among other things, stated that future GRC applications should include additional PSEP costs until implementation of the plan is complete⁵.

The workpapers that follow describe SDG&E's approach to completed pipeline and valve enhancement projects which are managed according to the following objectives:

- 1) Enhance public safety.
- 2) Comply with the directives of the Commission as set forth in Decision (D.)11-06-017.
- 3) Minimize customer and community impacts; and
- 4) Maximize the cost effectiveness of safety enhancement investments for the benefit of our customers.

As described in testimony, SDG&E PSEP Projects are managed according to the Stage Gate Review Process which sequences and schedules PSEP project workflow deliverables. Key design, management and execution actions and activities occur within and across the various stages. The Stage Gate Review Process for PSEP projects presented for review in this Application consisted of seven stages with specific objectives

¹ D.14-06-007 at 2-3

² *Id.*, Ordering Paragraph 2 at 59. The balancing accounts that were subsequently created for capital and O&M are known as the Safety Enhancement Capital Cost Balancing Account (SECCBA) and Safety Enhancement Expense Balancing Account (SEEBBA), respectively.

³ *Id.* at 39.

⁴ SDG&E has previously submitted A.16-09-005 (approved in D.19-02-004), and A.18-11-010 (approved in D.20-08-034).

⁵ D.16-08-003, OP 5 at 16.

for each stage, and an evaluation gate at the end of each stage to verify that those objectives have been met prior to proceeding to the next stage⁶.

Each workpaper that follows describes the activities and decision making undertaken in each functional area (Scoping, Engineering, Design and Planning, and Construction) to address the unique aspects of each project and details the final project costs that resulted from those activities. Two appendices have been included to aid in review of the workpapers; these include *Appendix A – Summary of Standard Planning and Construction Practices for Replacement, Hydrotest, Valve and Abandonment Projects*, which provides a synopsis of typical pre-construction and construction activities that occurred during SDG&E PSEP pipeline and valve enhancement projects, and *Appendix B – PSEP Glossary of Terms and Acronyms*, which will assist in defining specific construction and financial terminology used throughout the workpapers.

Sections II and III below provide a description of the structure of individual workpapers comprising of the completed pipeline and valve projects that are included for reasonableness review in this proceeding.

⁶ The seven-stage Stage Gate Review Process was implemented by the PSEP organization beginning in the First Quarter of 2013. It has since been reduced to five stages that still encompass all the deliverables of the seven stages, by combining Stages 1 and 2 and Stages 6 and 7. All of the projects in this Application were completed following the seven-stage Stage Gate Review Process. Future projects will be completed using the five-stage review process.

II. SDG&E REASONABLENESS REVIEW PIPELINE PROJECT WORKPAPERS STRUCTURE

The project workpapers that follow provide detailed components of the workpapers for the seven PSEP Pipeline pressure test, replacement, and abandonment projects subject to reasonableness review. The workpapers that follow support SDG&E’s first reasonableness review of its PSEP pipeline projects being submitted in a GRC. These projects were primarily placed in operation (NOP-ed) prior to April 30, 2019, and the costs have been reconciled as of December 31, 2020. Trailing costs or adjustments posted after December 31, 2020, are not reflected in the totals shown in Table 2 below nor in the workpapers.

Table 2 – Pipeline Hydrotest, Replacement and Abandonment Projects for the 2024 Reasonableness Review

Pipeline Workpaper Title	Project Scope (miles, rounded)			Workpaper Page
	Hydrotest	Replace	Abandon	
49-1 Replacement Project	0	5.207	5.291	WP-20
49-17 East Replacement Project	0	5.244	0	WP-47
49-17 West Replacement Project	0	1.671	0	WP-75
49-32-L Replacement Project	0	0.203	0	WP-100
La Mesa Gate Station Replacement Project	0	0.059	1.676	WP-118
49-16 Replacement and Hydrotest Project	0.295	0.804	0	WP-138
49-28 Abandonment Project	0	0	N/A	WP-181

Each workpaper is divided into five sections: A) Project Introduction; B) Engineering, Design and Planning; C) Construction; D) Project Costs; and E) Conclusion.

A general explanation is provided for each section’s objective is as follows:

A. PROJECT INTRODUCTION

1. Background and Summary

This section includes a high-level summary of the project scope which is also summarized in *Table 1: General Project Information*, providing overall project details such as mileage, pipe diameter (confidential), construction start/stop, project costs, etc. The pipe vintage listed reflects the vintage of the Category 4 Criteria mileage⁷.

⁷ Category 4: Pipelines segments that lack sufficient documentation of a post-construction strength test to at least 1.25 times the MAOP.

In addition, maps and satellite images are included to provide a perspective of the project in relation to the community it impacts and demonstrate the reasonable inclusion of accelerated and incidental pipe when remediating the Category 4 Criteria pipe segments and, when applicable, the rerouted pipeline alignment. Schematic drawings are sometimes included to illustrate and magnify pipeline interconnections and features that are not discernable from the map images.

B. ENGINEERING, DESIGN, AND PLANNING

1. Project Scope:

This section consists of *Table 2: Mileage Information* depicted by mileage type: Criteria, Accelerated, Incidental, New, and Total (both miles and feet). In some instances, an alignment offset, or rerouted pipeline results in “New” mileage that is greater than or less than the original route. The terms are defined as follows:

- Criteria Mileage is Phase 1A mileage. These are pipeline segments that lack sufficient documentation of a post-construction strength test to at least 1.25 times the MAOP and are located in Class 3 & 4 locations and Class 1 & 2 High Consequence Areas (HCA).
- Accelerated Mileage is pipeline that would otherwise be addressed in a later phase of PSEP under the approved prioritization process but have been advanced to Phase 1A to realize operating and cost efficiencies. Accelerated miles may be Phase 1B or Phase 2 mileage.
- Incidental Mileage is pipeline that does not fall within the scope of the Commission’s directives in D.11-06-017 or California Public Utilities Code section 958, but is addressed as part of a PSEP project, where its inclusion is determined to improve cost and program efficiency, address constructability, or facilitate continuity of testing.
- New Mileage is an alignment offset or rerouted pipeline segment that resulted in mileage that is greater than the original route.

A high-level summary of the progression of the project follows that chronicles the project evolution is typically organized as follows:

1. 2011 PSEP Filing indicates the type of project (replacement or hydrotest) and the Phase 1A mileage type as submitted in A.11-11-002.

2. Scope Validation summarizes the outcome of scope validation that included evaluation of existing pipeline documentation to confirm the project scope. Criteria mileage originally included for remediation may be increased or decreased due to the scope validation efforts. Criteria mileage may have been removed if a reduction in Maximum Allowable Operating Pressure (MAOP) was determined to be appropriate from a gas operating system perspective.
3. Engineering, Design and Constructability summarizes the constructability factors that influenced the project design, mileage, route, and construction methods.
4. Final Project Scope: summarizes the final project scope including mileage, construction method and other project activity, such as engineered crossings or new mainline valves (MLV) that contributed to the project complexity and/or cost.

2. Decision Tree Analysis

This section describes the Decision Tree Analysis that confirmed or modified the 2011 PSEP filing project's designation as either a pressure test or replacement project. In some instances, and after careful analysis, a third option (abandonment) is recommended, which determined that the pipeline is no longer needed for reliability from a gas operating system perspective. Typically, for pipeline projects greater than 1,000 feet in length, a Test-versus-Replace Analysis was conducted to compare costs of at least two scenarios (test or replace) and in some cases route alternatives were also considered. The project execution options were then presented to PSEP leadership at a stage gate review and approval was given to move forward with more detailed engineering and design efforts for the recommended project type. The workpapers summarize the relevant data points that were known at that time which influenced leadership's approval of the Decision Tree outcome. These data points are listed in the workpapers. Included are only the data points that influenced the Decision Tree outcome.

1. Shut In Analysis – describes the conditions, if any, when this pipeline can be shut in and if alternate service is available.
2. Customer Impacts – describes the impact, if any, to customers should a shut in be necessary.
3. Community Impacts – describes the construction activity impact on the neighboring community, typically traffic and noise impacts. The project alignment and route were influenced by the desire to minimize the impact on the community.

4. Permit Conditions – lists the known jurisdictional agencies in the construction area.
5. Piggability – states if the existing pipeline was/is piggable.
6. Pipe Vintage – reflects the predominate vintage of the preexisting Category 4 Criteria mileage pipeline segments.
7. Existing Pipe Attributes – lists the known pipeline features that could prevent the pipeline from being pigged or features that would need to be addressed prior to a hydrotest.
8. Longseam Type – states the longseam type, if known.
9. Longseam Repair History – provides a summary of recorded history of repair to the pipeline section.
10. Condition of Coating – provides a description of the coating, if known.
11. History of Leaks - provides a summary of recorded history of leaks on the pipeline section.
12. Constructability – describes the known factors that influenced the preliminary project design such as geographic constraints, existing substructures, adjacent highways, railroads, waterways, etc.
13. Other – describes other factors that influenced the Decision Tree outcome.

3. Engineering, Design, and Planning Factors

This section summarizes the notable engineering, design and planning activities. Planning is initiated by the analysis of pipeline attribute records, survey and mapping activities and site visits. During the initial planning and design process, information is updated, and new information is acquired regarding the permit conditions, existence of substructures, land rights, environmental issues, etc. that may differ from the original assumptions. These data points serve to influence the routing and design of the project, and the project schedule.

Once the detailed design is finished and construction documents are completed, necessary permits and authorizations are attained, pipeline materials are purchased, received, inspected, and prepared for turnover to the construction contractors. Material procurement is identified in two main phases, long-lead items and short-lead items. Long-lead material is identified and purchased at the 30% design stage while short-lead material is identified and purchased at the 60% design stage. When possible, SDG&E acquires materials by aggregating anticipated material needs (bulk purchasing) from many projects thereby making periodic purchases for larger quantities of material at a lower unit cost.

The information that influenced the preliminary pre-construction design described in this section of the workpaper and will include a summary of the conditions that influenced the preliminary pre-construction design and was the basis for the preliminary cost estimate. Only the relevant factors that impacted the project design are listed in the workpaper.

4. Scope Changes

This section describes any major scope or redesign changes made after the preliminary design and estimate were authorized. Changes are initiated to accommodate constructability or scheduling challenges⁸ and can occur at any stage of the Project lifecycle. Scope changes are authorized and documented using a scope change form. The revised project scope and design, given all the unique conditions and constraints of each project, considered cost effectiveness, system operating efficiencies, mitigation of customer and community impacts, and system capacity. The incremental costs associated with scope changes are *not* reflected in the estimated costs in Tables 4 and 5.

It is important to note that in some instances, when there are obstacles that apply to only a portion of the project, a project scope change involves the sectionalizing of the Project so that the unimpeded sections can be remediated as soon as practicable. The remaining sections are postponed until the obstacles have been addressed.

C. CONSTRUCTION⁹

1. Construction Contractor Selection

This section details the estimated (confidential) Construction Contractor Costs and the final negotiated (confidential) Construction Contractor costs. Construction activity begins with the selection of the Construction Contractor. For PSEP projects, the Construction Contractors are predominately selected through the Performance Partner Program process which are assigned to a geographical area. Five of the seven pipeline projects in this Reasonableness Review were assigned to the Performance Partner selected for that region. The Performance Partner Program allows for competitive pricing of projects and provides incentives associated with the program to encourage

⁸ Examples of the challenges frequently encountered are permit or land use restrictions, environmental constraints, customer impacts, traffic and other community impacts, system constraints, or pipe conditions identified once the pipe is exposed through potholing efforts.

⁹ Construction Activities further detailed in Appendix A to these workpapers, which provides a description of the large variety of field activities that may take place on a PSEP pipeline or valve project.

the Construction Contractors to further reduce costs. Occasionally, Performance Partners work outside their assigned regions to maintain a balance of work across all Performance Partners. When it was not practical to use a Performance Partner, the Construction Contractor was chosen through a competitive solicitation process.

In either instance, based on the Issue-for-Bid design (90% design drawing), a final scope of work (SOW) was prepared and provided to the Construction Contractor which was used to prepare a Target Price Estimate (TPE). Each project executed by a Performance Partner required negotiation to reach an agreed-upon TPE. In a competitive bidding process, SDG&E awarded the construction contract to the bidder that best met the selection criteria for the Project. For each Project, the workpaper will state in this section if the Project was executed through the Performance Partnership or through Competitive Bid and further details:

- SDG&E preliminary, confidential cost estimate for Construction Contractor costs, sometimes referred to as the Total Installed Cost (TIC).
- The Construction Contractor's confidential Target Price Estimate (TPE) or bid and the variance between the final bid and SDG&E preliminary estimate/TIC.

2. Construction Schedule

This section consists of *Table 3: Construction Timeline* depicting the construction start date, completion date and Notice of Operation (NOP) date for each project. For projects with more than one section, Table 3 will reflect the construction start date for the first section and the construction completion and NOP dates for the last section, if completed under different timelines.

3. Changes During Construction

This section summarizes the notable change orders that were initiated after the Project went to construction. Most of the pipeline replacement, hydrotest and abandonment projects presented for review in this Application are located in dense urban environments, which greatly adds to the complexity of the construction activities. Many of the construction challenges were mitigated and planned for; however, others were unanticipated and were addressed as they arose in the field. These unforeseen conditions may have required activities that were outside of the original scope of work upon which the TPE was established. As unexpected conditions were encountered during construction, the Construction Contractor described the conditions and the proposed solution to

SDG&E via a Request for Information (RFI) form. If authorized by the PSEP Project Manager, the solution was executed, and any incremental costs were documented via a change order. The workpapers for each project describe notable construction change orders (i.e. when the total construction change order costs are more than 10% of the TPE). Change orders are summarized in the workpapers and are categorized generally by cause.

4. Commissioning and Site Restoration

This section describes site restoration activities that are typically completed several weeks or even a month or more after the pipeline is returned to service. The site is demobilized, test water is disposed of or stored and removed for use on an adjacent project and the area is returned to its previous condition, which may include repaving and restoration of landscaping. Closeout activities are executed within the final months of the project lifecycle and include finalization of as-built drawings and uploading of updated information into the company's documentation and recordkeeping systems to reflect the final scope of work.

D. PROJECT COSTS

1. Cost Avoidance Actions:

This section describes the notable cost avoidance decisions and actions that are described in the project workpapers. Because PSEP projects are thoughtfully and prudently designed with safety and cost efficiency at top of mind, not all cost avoidance actions are specifically noted, and it would be impractical to list all the costlier design options that were briefly considered and rejected. Some typical areas of cost avoidance and cost savings are derived from planning and design choices that include reduction of project scope, choice of materials or bulk purchasing of materials, project designs that eliminate or reduce features that would complicate routine maintenance activities to reduce future maintenance costs, and planning and coordination of the PSEP project schedule to incorporate other projects to share resources or avoid duplicative or wasted effort. Prudent negotiation of terms with landowners and permit terms, as well as shared land use, are additional means of avoiding costs. Finally, costs are avoided through prudent engineering and design decisions made in the field to address and mitigate unanticipated conditions revealed once the pipe was exposed or otherwise identified during the latter stages of project execution.

2. Cost Estimate

Estimating activities were initiated with the approval of the Phase 1 Work Order Authorization (WOA) reflecting the estimated costs for preliminary design, mapping and survey activities. Subsequently, based on 30% design drawings, a Total Installed Cost (TIC) estimate was prepared using the most current version of the PSEP Estimating Tool. The TIC was presented to PSEP leadership and approval was required to move forward.

The TIC costs reflect Direct Costs only, which are typically used to prepare the Phase 2 WOA. The Phase 2 WOA includes Indirect Costs, and therefore, reflects the Total Loaded Project Cost estimate.

The approval of the Phase 2 WOA was required to proceed with execution of the project. Any significant project activities and costs subsequently added to the project scope after execution of the TIC would not be reflected in the estimated costs presented in Tables 4 and 5. These additional costs and activities are authorized and documented through the scope change process.

3. Actual Direct and Indirect Costs

The Estimated and Actual Costs shown in *Table 4: Estimated and Actual Direct Costs and Variances* in workpapers are defined as follows:

- Company Labor: Labor costs for SDG&E employees charging directly to the project, such as project managers, engineers, land services personnel, environmental services personnel, communication and outreach managers, construction managers, and field support personnel.
- Materials: Costs for materials that SDG&E purchased to complete the project, such as piping, valves, fittings, and other miscellaneous materials. Materials planned to be purchased by the construction contractor may be included in the construction contractor costs.
- Construction Contractor: Costs for Construction Contractor activity and materials or equipment acquired by the contractor. The actual construction contractor costs also include authorized change order costs and risk reward payments, minus construction credits, when applicable.

- Construction Management and Support: Costs for construction inspection, contamination mitigation, environmental monitoring, hydrotesting services, and other miscellaneous activities that occur in the field.
- Environmental: Costs for environmental assessments, monitoring, asbestos abatement, water and waste management, and miscellaneous environmental permits and fees not reflected in other cost categories.
- Engineering and Design: Costs for planning and design services, engineering, environmental services, land use and permitting fees not included in other categories, and project support, such as survey, mapping and miscellaneous expenses.
- Project Management Services: Contracted costs for project management services and general PSEP program support.
- ROW & Permits: Costs associated with permitting fees and land easement, or acquisition expenses not reflected in other cost categories.
- GMA: Programmatic PSEP costs.

Indirect Costs are listed in *Table 5: Estimated and Actual Indirect Costs, Total Costs, and Variances*. These costs are incremental overheads applied to PSEP projects. Indirect costs are for those activities and services that are associated with direct costs – such as payroll taxes, pension, benefits, and GMA. Also included is interest that SDG&E earns for funds used during construction for capital projects (AFUDC) and Property Tax for construction work in progress (CWIP) for capital projects.

There are several factors that may cause a variance between actual and estimated costs. Most of the differences are attributable to one or more factors: 1) estimates are based on a preliminary design, 2) reasonable changes in project scope are required to address conditions identified after the preliminary estimate was prepared, and 3) unforeseen and unplanned field conditions also contribute to variances between the preliminary estimate and actual costs.

4. Disallowances

Of the seven PSEP pipeline projects presented for review in this Application, five projects addressed footages of post-1955 pipe that lacked pressure test records, making portions of those projects subject to disallowance. In the project workpapers for these five projects, the disallowed scope is described, and the calculation of disallowed costs is provided. The disallowed project costs are



provided in the final workpapers for completeness, but the disallowed costs were previously recognized by SDG&E, are not recorded in the PSEP balancing accounts, and are not included in the revenue requirement presented for review in this Application, as described in testimony.

III. SDG&E REASONABLENESS REVIEW VALVE ENHANCEMENT PROJECT WORKPAPER STRUCTURE

The workpapers that follow consist of final reports that describe the actions taken in each of SDG&E six Pipeline Safety Enhancement Plan (PSEP) valve enhancement projects included in the 2024 Reasonableness Review. The workpapers support SDG&E’s first reasonableness review of its PSEP valve enhancement projects being submitted in a GRC. These projects were primarily placed in operation (NOP-ed) prior to July 23, 2019 and the costs have been reconciled as of December 31, 2020. Trailing costs or adjustments posted after December 31, 2020 are not reflected in the totals shown in Table 2 below nor in the workpapers.

Table 3 – Valve Project Bundles submitted in the 2024 Reasonableness Review

Valve Workpaper Title	Project Scope (valves, sites)	Workpaper Page
49-11 Valve Enhancement Project	1 Valve, 1 Site	WP-198
49-16 Valve Enhancement Bundle	4 Valves, 3 Sites	WP-213
49-18 Mission Valley Valve Enhancement Project	1 Valve, 1 Site	WP-238
49-23 Valve Enhancement Bundle	2 Valves, 2 Sites	WP-253
49-32 Valve Enhancement Project	1 Valve, 1 Site	WP-270
1601 Valve Enhancement Project	1 Valve, 1 Site	WP-287

Each workpaper is divided into five sections: A) Project Introduction; B) Engineering, Design and Planning C) Construction; D) Project Costs; and E) Conclusion.

An explanation describing each section’s objective is as follows:

A. PROJECT INTRODUCTION

1. Background and Summary

When practical and anticipated to provide project management and cost efficiencies, SDG&E bundled multiple valve enhancement project sites for project management and execution. Included in this background and summary section is *Table 1: General Project Information*, which provides overall valve project details by site such as location, valve type(s), and valve and site enhancements. In addition, maps and satellite images are included for the entire bundle (when applicable) and for each site to provide a perspective of the project in relation to the community it impacts, and the other project sites. Schematic drawings are sometimes included to illustrate and magnify pipeline interconnections and features that are not discernable from the map images.

B. ENGINEERING, DESIGN, AND PLANNING

As described in testimony, the SDG&E Engineering group guides execution of the Valve Enhancement Plan and designates which valves require remote automation capability to enable optimal system isolation in the event of an emergency.

1. Project Scope

Included in this section is *Table 2: Final Project Scope* which details valve number, valve size (confidential), installation type and function. Project scoping activities include review of existing documentation and a detailed system flow analysis to confirm the scope of the project. As appropriate, modifications are made to the plan to update the scope to include or remove valves as necessary to achieve planned isolation.

- 2011 PSEP Filing indicates valves identified as a candidate for automation as submitted in A. 11-11-002.
- Updated Scope summarizes the outcome of scope validation and documentation to confirm the project scope.
- Engineering, Design and Constructability summarizes the constructability factors that influenced the project design and route.
- Final Project Scope summarizes the final project scope including the installation of any new automated valves, actuators, vaults, power equipment, communications equipment, or the necessary automation equipment that contributed to the project complexity and/or cost.

2. Site Evaluation and Planning

Once a PSEP valve project is initiated and preliminary scope is identified, a site visit is conducted to inspect the valve, confirm the normal valve position (open or closed), location of the valve (above-grade or below-grade), valve type and identify other field and site conditions that could impact the successful automation of the valve. Upon receipt of these data points, project engineering and design commences. In cases where it is warranted, the PSEP project team recommends modifications to the project scope and selects an alternate valve for automation or recommends that the valve be moved to a location out of a roadway that is safer and less impactful to customers when routine maintenance is being conducted. A schematic drawing is included in this section to

depict the existing valves and valves that were enhanced with remote isolation capability to enable system isolation.

Once the detailed design is prepared and construction documents are completed, necessary permits and authorizations are attained, and required valve materials are purchased, received, and prepared for turnover to contractors.

3. Scope Changes

Throughout the Engineering, Design and Planning process, constructability or scheduling hurdles are sometimes revealed that require design changes, such as the addition or removal of valves from the project scope, a change in which valves were being enhanced, or a change in the type of enhancement. Scope changes are reviewed and authorized. The incremental costs associated with a subsequent scope change would *not* be reflected in the estimated costs in *Tables 4 and 5*.

C. CONSTRUCTION

1. Construction Contractor Selection

SDG&E utilize electrical contractors to execute PSEP valve automation work (installation of controls, wiring, communication and electrical work) and requires additional services of a mechanical construction contractor when a valve is relocated or other pipeline work is required. Valve mechanical work is included within the Performance Partner's anticipated activities within each geographic region. When a Performance Partner is not used, the project is competitively bid. Similar to the Performance Partner Program, SDG&E created an Alliance Contractor Program for PSEP electrical contractors. Unlike the Performance Partner Program however, the Alliance Partnership does not include a risk reward provision. Three electrical contractors were selected as Alliance Contractors, following receipt of competitive bids from eight qualified electrical contractors through a competitive solicitation process. Alliance Contractors are assigned projects based on workload and geographic considerations.

Once the Issue-for-Bid design (90% design drawing) is completed, a final scope of work is prepared and provided to the Electrical and Mechanical Contractors, which is used by the Electrical and Mechanical Contractors to prepare their construction cost estimates. Each project executed by an Alliance Contractor or Performance Partner requires negotiation of an agreed-upon estimated cost. The Contractor selection process for each project is described in the project workpapers.

2. Construction Schedule

Valve projects typically require less mobilization efforts than a pipeline project because the scope of work is much more contained and less invasive to the project site. Demobilization requires less effort therefore, contractors frequently work on and manage multiple adjacent projects at the same time, moving from site to site to execute work when materials and other conditions are available. This creates efficiencies and reduces downtime or standby charges as the project team can remain active, but extends the duration of the construction. *Table 3: Construction Timeline* lists the Construction Start and Completion Dates and includes the days on site which is a better indicator of the complexity of the project execution. It also lists the Commissioning Date which is the date that point-to-point contact verification was achieved indicating that the valve was remotely operable.

3. Changes During Construction

Once the project proceeds to construction, site conditions may have changed, or other unanticipated factors may be identified. The Construction Contractor describes the unanticipated conditions encountered during construction and the proposed solution to SDG&E via an RFI form. If authorized by the PSEP Project Manager, the solution is executed, and the incremental costs are documented via a change order. The workpapers for each project describe notable construction change orders (i.e., when the total construction change order costs are more than 10% of the TPE).

4. Commissioning and Site Restoration

Commissioning activities include site restoration, a site Acceptance Test, which is necessary to obtain agreement from SDG&E Gas Operations that the valve project is complete before turnover. The site is demobilized, and the area is returned to its previous condition. This may include repaving and restoration of landscaping. Closeout activities are executed within the final months of the project lifecycle and include finalization of as-built drawings and uploading of updated information into the company's documentation and recordkeeping systems to reflect the final scope of work.

D. PROJECT COSTS

1. Cost Avoidance Actions

This section describes the notable cost avoidance decisions and actions that are described in the project workpapers. Because PSEP projects are thoughtfully and prudently designed with safety and cost efficiency at top of mind, not all cost avoidance actions are specifically noted, and it would

be impractical to list all the costlier design options that were briefly considered and rejected. Some typical areas of cost avoidance and cost savings are derived from planning and design choices that include reduction of project scope, choice of materials or bulk purchasing of materials, project designs that eliminate or reduce features that would complicate routine maintenance activities to reduce future maintenance costs, and planning and coordination of the PSEP project schedule to incorporate other projects to share resources or avoid duplicative or wasted effort. Prudent negotiation of terms with landowners and permit terms, as well as shared land use, are additional means of avoiding costs. Finally, costs are avoided through prudent engineering and design decisions made in the field to address and mitigate unanticipated conditions identified during construction.

2. Cost Estimate

Estimation activity is initiated in Stage 1 with approval of the Phase 1 WOA reflecting the estimated costs for preliminary design, mapping and survey activities. Subsequently, based on 60% design drawings, a TIC estimate is prepared using the most current version of the PSEP Estimating Tool available. The TIC is presented to PSEP leadership at a Stage 3 gate review and approval is required to move forward. The TIC costs reflect direct costs only, which are typically used to prepare the Phase 2 WOA. The Phase 2 WOA includes indirect costs, and therefore, provides a total loaded project cost estimate. Approval of the Phase 2 WOA is required to proceed with execution of the project. Any significant project activity and costs subsequently added to the project scope after execution of the TIC would not be reflected in the estimated costs presented in Tables 4 and 5 in the project workpapers. These additional costs and activities are authorized and documented through the scope change process discussed above.

3. Actual Direct and Indirect Costs

The Estimated and Actual Costs shown in *Table 4: Estimated and Actual Direct Costs and Variances* in workpapers are defined as follows:

- Company Labor: Labor costs for SDG&E employees charge directly to the project, such as project managers, engineers, land services personnel, environmental services personnel, communication and outreach managers, construction managers, and field support personnel.

- Materials: Costs for materials that SDG&E purchased to complete the project, such as valves, fittings, and other miscellaneous materials. Materials planned to be purchased by the construction contractor may be included in the construction contractor's costs.
- Mechanical Construction Contractor: Costs for mechanical construction activities performed by the Mechanical Contractor and materials or equipment acquired by the contractor. The actual Mechanical construction contractor costs also include authorized change order costs and risk reward payments, minus construction credits, when applicable.
- Electrical Contractor: Costs for electrical construction activity and materials or equipment acquired by the Electrical Contractor. The actual Electrical construction contractor costs also include authorized change order costs, when applicable.
- Construction Management and Support: Costs for construction inspection, contamination mitigation, environmental monitoring, hydrotesting services, and other miscellaneous activities that occur in the field.
- Environmental: Costs for environmental assessments, monitoring, asbestos abatement, water and waste management, and miscellaneous environmental permits and fees not reflected in other cost categories.
- Engineering and Design: Costs for planning and design services, engineering, environmental services, land use and permitting fees not included in other categories, and project support, such as survey, mapping, and miscellaneous expenses.
- Project Management Services: Contracted costs for project management services and general PSEP program support.
- ROW & Permits: Costs associated with permitting fees and land easement, or acquisition expenses not reflected in other cost categories.
- GMA: Programmatic PSEP costs.

Indirect Costs are listed in *Table 5: Estimated and Actual Indirect Costs, Total Costs, and Variances* in the workpapers. These costs are incremental overheads applied to PSEP projects. Indirect costs are for those activities and services that are associated with direct costs – such as payroll taxes, pension, benefits, and GMA. Also included is interest that SDG&E earns for funds used during construction for capital projects (AFUDC) and Property Tax for construction work in progress (CWIP) for capital projects.

There are several factors that may cause a variance (delta) between actual and estimated costs. Most of the differences are attributable to one or more factors: 1) estimates are based on a preliminary design, and 2) unforeseen and unplanned field conditions also contribute to variances between the preliminary estimate and actual costs.

WP-20 – 197

SDG&E Reasonableness Review

Pipeline Project Workpapers

REASONABLENESS REVIEW PIPELINE PROJECTS

Table 2 – Pipeline Hydrotest, Replacement and Abandonment Projects for the 2024 Reasonableness Review

Pipeline Workpaper Title	Project Scope (miles, rounded)			Workpaper Page
	Hydrotest	Replace	Abandon	
49-1 Replacement Project	0	5.207	5.291	WP-20
49-17 East Replacement Project	0	5.244	0	WP-47
49-17 West Replacement Project	0	1.671	0	WP-75
49-32-L Replacement Project	0	0.203	0	WP-100
La Mesa Gate Station Replacement Project	0	0.059	1.676	WP-118
49-16 Replacement and Hydrotest Project	0.295	0.804	0	WP-138
49-28 Abandonment Project	0	0	N/A	WP-181

I. SUPPLY LINES 49-1 REPLACEMENT PROJECT

A. Background and Summary

Supply Lines 49-25 and 49-26 were contiguous pipelines that extended approximately five miles across the Mission Valley corridor in a highly developed and heavily congested area in San Diego. The two pipelines ran parallel to, and in some locations, under major interstate highways. The alignment of Supply Line 49-25 and Supply Line 49-26 began east of Interstate 5 in the Old Town area and continued east crossing under Interstate 8, Interstate 805, and Route 163 a total of four times. These pipelines supported Supply Line 49-32 to the west and Supply Line 49-12 and Supply Line 49-17 to the east. The pipelines were primarily routed across a Class 3 location. The original vintage of these pipelines dates back to 1948 and 1942 respectively; however, throughout the years as the area became more developed, the pipelines were modified to accommodate various underground civil projects and as a result, the pipelines had multiple bends installed rendering the pipelines non-piggable.

This report describes the activities associated with the Supply Line 49-1 Replacement Project that consists of the replacement and reroute of approximately five miles of pipeline for Supply Line 49-25 and Supply Line 49-26, the installation of two new mainline valves (MLVs), installation of three new regulator stations, and the abandonment of four regulator stations. Both existing pipelines, Supply Line 49-25 and Supply Line 49-26, were abandoned and replaced by one new pipeline named Supply Line 49-1. The new pipeline was downsized from the existing pipelines predominate [REDACTED] diameter pipeline to a [REDACTED] diameter pipeline to standardize the pipeline and enhance piggability. The specific attributes of this project are listed in Table 1 below. The total loaded project costs are \$64,339,516.

Final Report for Supply Lines 49-1 Replacement Project

Table 1: General Project Information

Project Name	Supply Line 49-1
Project Type	New - Replacement
Length	5.207 miles
Location	City of San Diego
Class	3
MAOP (<i>confidential</i>)	[REDACTED]
Pipe Vintage	2019
Construction Start	08/11/2014
Construction Finish	06/14/2019
New Diameter (<i>confidential</i>)	[REDACTED]
New SMYS (<i>confidential</i>)	[REDACTED]
Project Name	Supply Line 49-25
Project Type	Abandonment
Length	1.745 miles
Location	Mission Valley
Class	3
MAOP (<i>confidential</i>)	[REDACTED]
Pipe Vintage	1948
Construction Start	08/11/2014
Construction Finish	05/27/2016
Original Pipe Diameter (<i>confidential</i>)	[REDACTED] h
Original SMYS ¹ (<i>confidential</i>)	[REDACTED]
Project Name	Supply Line 49-26
Project Type	Abandonment
Length	3.546 miles
Location	City of San Diego
Class	3
MAOP (<i>confidential</i>)	[REDACTED]
Pipe Vintage	1942
Construction Start	10/30/2014
Construction Finish ²	12/20/2018
Original Pipe Diameter (<i>confidential</i>)	[REDACTED]
Original SMYS ³ (<i>confidential</i>)	[REDACTED]

¹ Highest percentage of Specified Minimum Yield Strength (SMYS) of Category 4 Criteria pipe.

² Construction Finish duration includes abandonment site restoration related activities.

³ Highest percentage of Specified Minimum Yield Strength (SMYS) of Category 4 Criteria pipe.

Final Report for Supply Lines 49-1 Replacement Project

Table 1: General Project Information (cont)

Project Costs (\$)	Capital	O&M	Total
Loaded Project Costs	64,339,516	-	64,339,516
Disallowed Costs	1,040,938	-	1,040,938

Final Report for Supply Lines 49-1 Replacement Project

B. Maps and Images

Figure 1: Satellite Image of Supply Line 49-1 Replacement Project

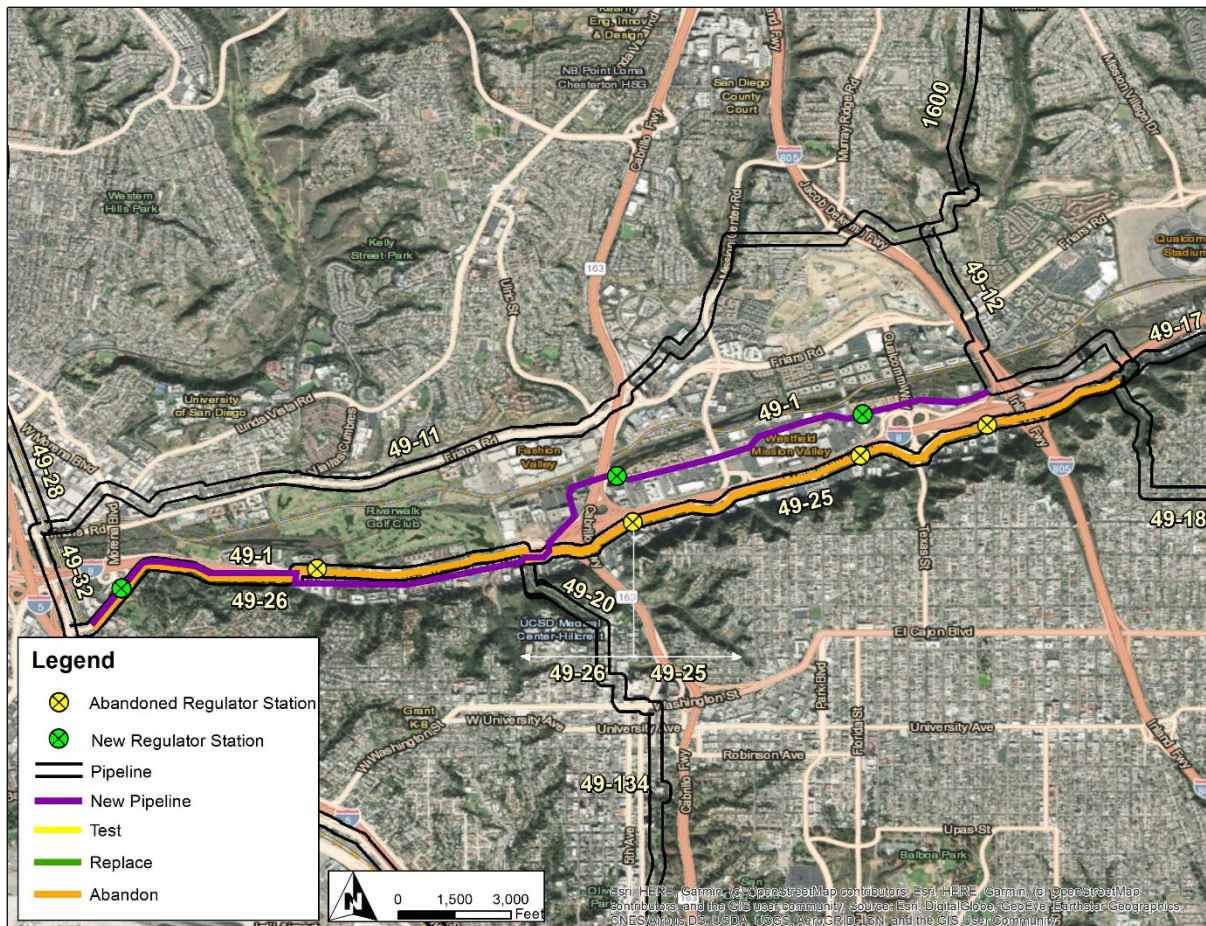

Final Report for Supply Lines 49-1 Replacement Project

Figure 2: Overview Map of Supply Line 49-1 Replacement Project

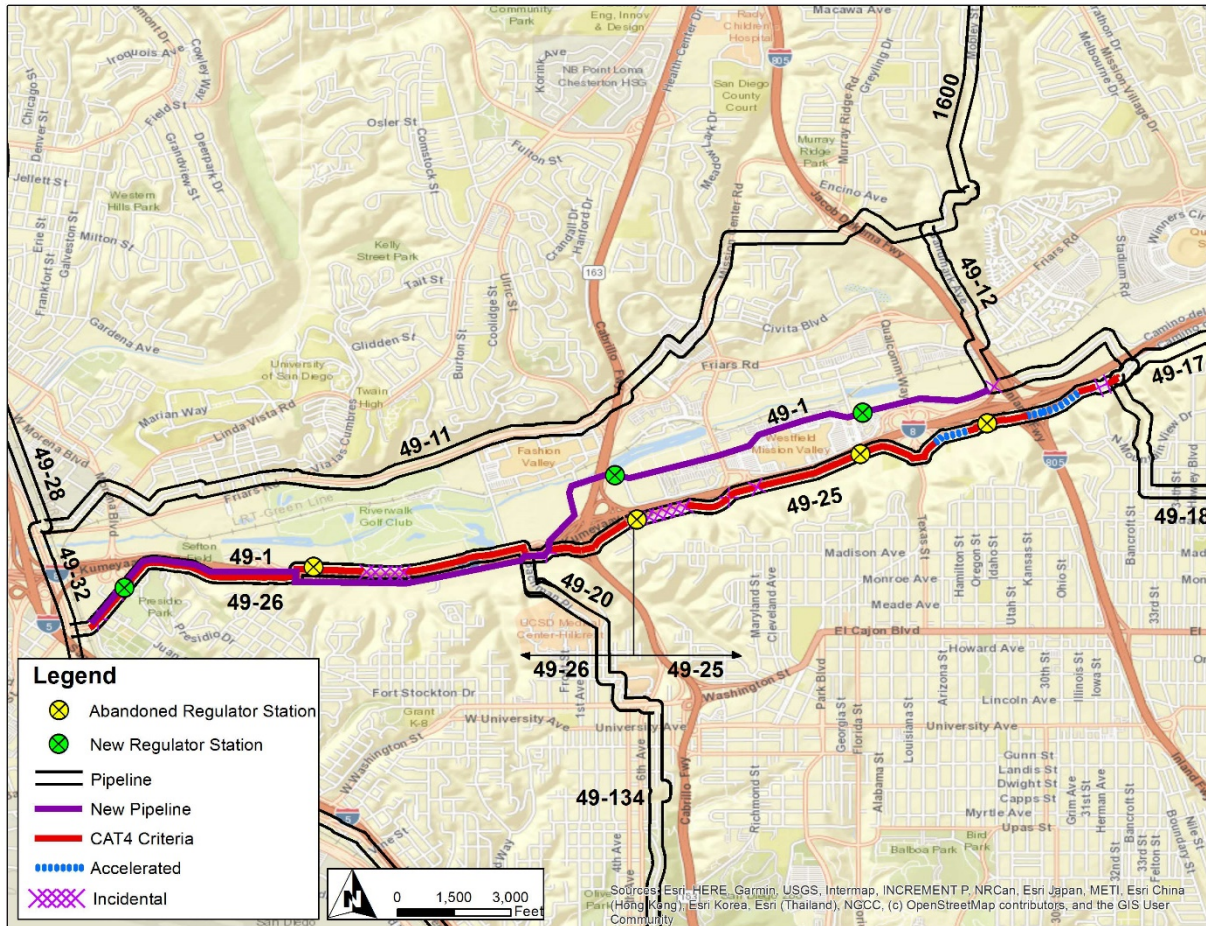

Final Report for Supply Line 49-1 Replacement Project

II. ENGINEERING, DESIGN, AND PLANNING

A. Project Scope

Table 2: Mileage Information

	Criteria	Accelerated ⁴	Incidental	New	Total ⁵
Final Mileage	3.968 mi.	0.441 mi.	0.717 mi.	0.081 mi.	5.207 mi.
New Supply Line 49-1	20,953 ft.	2,328 ft.	3,788 ft.	429 ft.	27,498 ft.

SoCalGas and SDG&E presented a conceptual project scope in workpapers supporting the 2011 PSEP filing.⁶ Prior to initiating execution of the Project in 2014, SDG&E reviewed existing pipeline records to validate the scope of these projects. During the Engineering, Design, and Planning phase, SDG&E further refined the scope. This progression of the project scope is summarized as follows:

1. 2011 PSEP Filing: SoCalGas and SDG&E identified Supply Line 49-25 as a Phase 1A Replacement Project comprised of 1.566 miles of Category 4 Criteria pipe and 0.712 miles of Accelerated pipe and Supply Line 49-26 as a Phase 1A Replacement Project comprised of 2.396 miles of Category 4 Criteria pipe and 0.219 miles of Accelerated pipe.
2. Scope Validation: Through SDG&E’s scope validation activities, after the 2011 filing and before initiating execution of the Project, SDG&E reduced the scope of the Supply Line 49-25 project by 137 feet of Category 4 Criteria pipe and increased the scope of the Supply Line 49-26 project by 174 feet of Category 4 Criteria pipe.

⁴ Accelerated mileage includes Phase 2B pipe. Phase 2 includes pipelines with record of a pressure test, but without record of a pressure test to modern – Subpart J – standards (Phase 2B). The Accelerated mileage was included to realize efficiencies and to enhance project constructability.

⁵ Values may not add to total due to rounding.

⁶ See Amended PSEP of SoCalGas and SDG&E, submitted December 2, 2011, in R.11-02-019 and subsequently transferred to A.11-11-002.

Final Report for Supply Line 49-1 Replacement Project

3. Engineering, Design, and Constructability:
 - a. The Project Team determined that a new supply line that rerouted the existing Supply Line 49-25 north of the highway and replaced and realigned Supply Line 49-26 would be the most effective means of meeting the PSEP objectives.
 - b. The Project Team determined that the replacement pipe could be downsized to the same diameter pipe as the pipelines being tied into because there were no existing nor future demand expectations that required the larger capacity.
 - c. The Project Team determined that the rerouted alignment would reduce the number of regulator stations and highway crossings and would reduce the number of trenchless highway under crossings from four to one by locating three of the crossings through existing underpasses using open trench installation.
 - d. The Project Team determined that Supply Line 49-25 and Supply Line 49-26 should remain in service until the new Supply Line 49-1 was completed in order to maintain uninterrupted service to customers. Both lines were to then be abandoned once Supply Line 49-1 was operational and in service.
4. Final Project Scope: The final project scope consists of the installation of a new pipeline, Supply Line 49-1, comprised of 5.207 miles of [REDACTED] diameter pipeline, the replacement and relocation of three new regulator stations, two MLVs, and the abandonment of Supply Line 49-25 and Supply Line 49-26.

B. Decision Tree Analysis

SDG&E performed separate but simultaneous PSEP Decision Tree analyzes of Supply Line 49-25 and Supply Line 49-26 and in both instances SDG&E identified replacement as the more prudent option.

Supply Line 49-25:

For pipeline segments longer than 1,000 feet in length, under the approved PSEP Decision Tree, SDG&E completes a preliminary review to determine whether SDG&E can manage customer service impacts if the pipeline segment is taken out of service for a

Final Report for Supply Line 49-1 Replacement Project

period of two to six weeks to complete pressure testing. Where mitigation of customer impacts to remove the line from service for pressure testing is feasible, SDG&E compares the costs, constructability, risks, and benefits of pressure testing and replacement to determine whether pressure testing or replacement is the more prudent option. Key considerations that support SDG&E's determination to replace this segment include:

1. Shut-In Analysis: The Project Team completed a Request for Engineering Review (RER) analysis and concluded that this pipeline could not be taken out of service. The RER also concluded that if a replacement pipe were installed, the system could still operate adequately if a smaller replacement pipe diameter was used.
2. Customer Impact: This pipeline serves three regulator stations and over 400 customers, and directly feeds Supply Lines 49-12 and 49-17.
3. Community Impacts: Pipeline alignment runs along a heavily traveled street where multiple commercial and retail businesses are located.
4. Permitting Agencies: The Project Team obtained permits from the City of San Diego, Caltrans and the San Diego Metropolitan Transit System (MTS).
5. Piggability: Non-piggable.
6. Predominant Pipe Vintage: The pipeline was installed in 1948 with some modifications made between 1949 and 1994.
7. Existing Pipe Attributes: Supply Line 49-25 consists of varying pipe diameters, non-piggable miter bends, and elbows.
8. Long Seam Type: Varies. Unknown, longitudinal seam and girth welds identified as early submerged arc weld (SAW).
9. Long Seam Repair History: The Project Team did not identify any issues.
10. Condition of Coating: The Project Team did not identify issues.
11. History of Leaks: Longitudinal seam leak repaired in 1968.

Supply Line 49-26:

Pipeline segments installed prior to 1946 that are not capable of being assessed using in-line inspection technology are identified for replacement under the approved PSEP Decision Tree. As explained in the testimony supporting the approved PSEP, as part of

Final Report for Supply Line 49-1 Replacement Project

the work previously completed during implementation of the federal gas transmission pipeline integrity management regulations (49 CFR 192, Subpart O), SDG&E had already identified, retrofitted, and in-line inspected pre-1946 transmission pipelines that were constructed using acceptable welding techniques, and are operationally suited to in-line inspection. The remaining pre-1946 segments in the SDG&E system are not suited for in-line inspection, likely have non-state-of-the-art welds, and would require significant investment for retrofitting to accommodate in-line inspection tools. Accordingly, consistent with the Commission's directive in D.11-06-017 to "address retrofitting pipeline to allow for inline inspection tools," the requirement in California Public Utilities Code section 958 that upon completion of the PSEP, where warranted, pipelines are to be capable of accommodating in-line inspection devices, and the overarching objectives of PSEP to enhance the safety of the pipeline system in a proactive, cost effective manner, the approved PSEP Decision Tree identifies pre-1946 non-piggable pipeline segments for abandonment and/or replacement. Key considerations that support SDG&E's determination to replace this segment include:

1. Shut-In Analysis: The Project Team completed a Request for Engineering Review (RER) analysis and concluded that this pipeline could not be taken out of service. The RER also concluded that if a replacement pipe were installed, the system could still operate adequately if a smaller replacement pipe diameter was used.
2. Customer Impact: This pipeline serves over 32,000 customers and another major noncore customer with a cogen plant. It is also the direct feed to Supply Line 49-32.
3. Community Impacts: Pipeline alignment runs along a heavily traveled street where multiple commercial and retail businesses are located, including the San Diego Hotel Circle.
4. Permitting Agencies: The Project Team obtained permits from City of San Diego, Caltrans and the San Diego Metropolitan Transit System (MTS).
5. Piggability: Non-piggable.
6. Pipe Vintage: The pipeline was originally installed in 1942 with modifications made between 1946 and 2012.

Final Report for Supply Line 49-1 Replacement Project

7. Existing Pipe Attribute: The Project Team identified back to back elbows on Supply Line 49-26 rendering the pipeline non-piggeable.
8. Long Seam Type: Unknown.
9. Long Seam Repair History: No identified issues.
10. Condition of Coating: No identified issues.
11. History of Leaks: No Identified issues.

C. Engineering, Design, and Planning Factors

SDG&E reviewed pipeline drawings and other information, contacted internal planning groups, communicated with external stakeholders, conducted survey activities, including reviewing public records and potholing of the area to confirm the presence of underground utilities and substructures, and completed a pre-design site walk and determined that combining these two replacement projects into a single new rerouted and realigned pipeline would most effectively meet the objectives of PSEP. Key factors that influenced the engineering and design of the Project are as follows:

1. Reroute: The Project Team determined that the rerouted pipeline would run north of Interstate 8 along Camino De La Reina. The rerouted alignment could be executed by crossing through existing underpasses using open trench excavation rather than trenchless construction methods directly beneath the interstate. This reroute was determined to be the best option as it eliminated the following conditions:
 - a. A portion of existing Supply Line 49-26 ran underneath Interstate 8 in two locations with limited accessibility. Avoiding this location allowed for sufficient room to safely perform future maintenance on the pipeline.
 - b. The realignment eliminated one of the highway under crossings under Interstate 8.
 - c. The new alignment allowed redesign of taps off the pipeline and eliminated one regulator station, reducing future inspection and maintenance costs.
 - d. The selected route was most optimal due to the least amount of known substructure conflicts and ease of obtaining land rights for the new pipeline.

Final Report for Supply Line 49-1 Replacement Project

2. Shut-In Analysis: The Project Team completed a Request for Engineering Review (RER) analysis that concluded the lines could not be shut in and that service would need to be maintained through the existing pipelines. The Project Team determined that the existing pipelines could only be abandoned once the installation of the new Supply Line 49-1 was completed and operational.
3. Customer Impact: When transitioning from the old pipeline to the replacement pipeline, and to maintain service to a cogen plant, the Project Team coordinated the shut-in with the customer's operational schedule. For other situations, the Project Team utilized pressure control fittings (PCF) to maintain uninterrupted service to customers served by Supply Line 49-32.
4. Community Impact: The location of the project is in a very busy commercial and residential area which required extensive traffic control measures and work restrictions to mitigate construction impact to businesses and residents along the construction route.
5. Diameter Changes: Supply Line 49-25 consisted of predominately [REDACTED] diameter pipe. The Project Team analyzed typical load demands and future capacity planning with a replacement diameter of [REDACTED] and determined it to be sufficient to support existing and anticipated capacity demands and would further enhance piggybackability by standardizing the pipeline diameter.
6. Schedule Coordination:
 - a. The Project Team executed construction in non-contiguous sections to coincide with the issuance of the Caltrans permits to offset and minimize delays.
 - b. Supply Line 49-25 and Supply Line 49-26 remained in service until the new Supply Line 49-1 was completed in order to maintain uninterrupted service to customers. Supply Line 49-25 and Supply Line 49-26 were abandoned once Supply Line 49-1 was operational and in service.
7. Known Substructures: The Project Team reviewed existing records and identified multiple substructures along the replacement route.
8. Permit Conditions:

Final Report for Supply Line 49-1 Replacement Project

- a. The Project Team obtained encroachment, noise control, resurfacing moratorium, and traffic control from the City of San Diego.
 - b. The Project Team obtained encroachment and traffic control from Caltrans.
 - c. The Project Team obtained traffic control from MTS/MTDB.
9. Land Use:
- a. The Project Team installed the new regulator stations in the franchise right of way (ROW) in the City of San Diego.
 - b. The Project Team received approval from Caltrans to utilize one of their properties as a laydown yard.
 - c. The Project Team utilized multiple other laydown yards along the new pipeline route for equipment storage and staging.
10. Environmental: Portions of the pipeline route were within the historic and culturally sensitive Old Town area necessitating on-site archaeological and environmental monitors during construction. Construction activity in this area required soil screening during excavation and pipelay thus adding more time and labor to the project schedule.
11. Valves: The Project Team installed two new [REDACTED] MLVs on the new Supply Line 49-1.
12. Constructability: The pipeline is routed along a densely populated commercial area along a heavily traveled roadway. The pipeline ties-in under Interstate 805, crosses State Route 163, and crosses Interstate 8.

D. Scope Changes

Through engineering, design, and planning activities, SDG&E determined that changes in scope were appropriate to enhance the design of the Project and address engineering factors. As a result, the scope of work that the preliminary cost estimate was based on does not fully reflect the final scope. Summarized below are notable changes in scope made after the preliminary cost estimate was developed and approved.

1. Permit Restrictions (City of San Diego):

Final Report for Supply Line 49-1 Replacement Project

- a. For this project, more detailed and complex Traffic Control Plans (TCP) were required than anticipated when the Total Installed Cost (TIC) was prepared. For example, the work area was restricted to one city block and the City of San Diego requested that CAD drawings for each site be provided when applying for TCPs for each site adding to the cost and extending the project schedule.
 - b. The permit conditions required that the road be completed repaved during restoration activities.
 - c. The permit conditions limited the number of trench plates that could be used at one time impacting construction productivity.
 - d. Due to the high volume of traffic, work hours were shortened in some areas and in other areas, work hours were restricted to evening hours, increasing cost and extending the schedule.
2. Scheduling/Permit Delays (Caltrans): The Project Team scheduled construction based on the anticipated delivery dates of the Caltrans permits, however, the receipt of these permits was delayed.
 3. Constructability: To resolve constructability challenges, a segment of the project was redesigned to include a 300 foot horizontal directional drill (HDD) to cross under multiple utilities and the east tie-in location was redesigned to avoid conflicting substructures.

III. CONSTRUCTION

A. Construction Contractor Selection

The Project Team prepared an initial cost estimate based on the preliminary design. Following completion of the more detailed engineering, design, and planning activities described above, the Project Team directed SDG&E crews to start construction on the portion of the project that was short and less complex, similar to routine work that SDG&E crews typically perform. The Project Team took this approach due to limited contractor crew availability and to initiate construction as soon as practicable. For the remaining project segments, the Project Team directed the Performance Partner contractor to prepare cost estimates based on the more detailed engineering package, that included the updated design described in the discussion of notable Scope Changes above. SDG&E awarded the construction contract for this Project to the Performance Partner.

1. SDG&E’s Preliminary Construction Cost Estimate (confidential): SDG&E’s preliminary cost estimate for construction was [REDACTED].
2. Construction Contractor’s Target Price Estimate⁷ (confidential): The Construction Contractor’s cost estimate was [REDACTED], which was [REDACTED] than SDG&E’s preliminary cost estimate for construction.

B. Construction Schedule

Table 3: Construction Timeline

Supply Line 49-1 Replacement	
Construction Start Date	08/11/2014
Construction Completion Date ⁸	06/14/2019
NOP Date	09/20/2016
Supply Line 49-25 and 49-26 Abandonment	
Construction Start Date	05/14/2018
Construction Completion Date	06/14/2019
NOP Date	04/30/2019

⁷ Scope of work estimated by the Construction Contractor was for the remaining scope of work after the SDG&E crews construction efforts.

⁸ Construction Finish duration includes abandonment site restoration related activities.

Final Report for Supply Line 49-1 Replacement Project

C. Changes During Construction

The conditions summarized below were encountered during construction. Activities to address or mitigate these conditions resulted in approximately \$826,000 in change orders.

1. Schedule Delay: The Project Team identified multiple unknown substructures during construction that resulted in alignment changes and unforeseen conditions, personnel and equipment were on site for an additional 27 days. Field overheads (fixed costs) were also extended to support the completion of this project.
2. Tie-In: The Construction Contractor exposed the proposed tie-in location and identified an unknown bend in the pipe resulting in additional excavation to relocate the tie-in point and avoid the bent pipe.
3. Field Design Changes:
 - a. The Construction Contractor provided additional support with field testing the regulator stations.
 - b. Due to additional pipeline depth requirements to go beneath structures, the blow-off extensions of the valves being installed had to be extended. Additional traffic control and moving the trench plates was also necessary.
 - c. The Project Team installed 2-inch steel lines for active carbon canisters to filter higher than expected odorant levels during the nighttime purging the new pipeline.
4. Weather: Throughout the Project, the Project Team remediated stormwater damage by covering open excavations, pumping water, re-shoring washouts, stabilizing excavations with sand, continued temporary backfill of excavations where the road had undermined, revalidating the integrity of the pipe coating, clearing pipe of debris, replacing temporary asphalt patches, removing asphalt and rocks, and also replacing 15 feet of pavement.
5. Excavation:

Final Report for Supply Line 49-1 Replacement Project

- a. During excavation, construction crews encountered ground water. To address this unanticipated condition and enhance employee safety, SDG&E authorized construction crews to excavate larger trenches and construct additional shoring.
 - b. The Contractor prepared a laydown yard for the delivery of contaminated soil by installing additional Best Management Practices (BMPs) around soil piles.
6. Other: The Construction duration was four months longer than estimated. This resulted in the use of a laydown yard four additional months. The Project Team initially planned to use the laydown yard for five months.
7. Substructures: This project underwent additional alignment changes due to the discovery of an unmarked waterline. The Construction Contractor also excavated a previously unidentified concrete treated road base, this resulted in the Construction Contractor providing additional potholing, saw cutting, paving, shoring, and excavation activities to maintain minimum separation from road base.

Final Report for Supply Line 49-1 Replacement Project

Figure 5: Nighttime Trenching Under the Interstate 8 Freeway



Final Report for Supply Line 49-1 Replacement Project

Figure 6: Nighttime Pipelay Under the Interstate 8 Freeway



Final Report for Supply Line 49-1 Replacement Project

Figure 7: Highway 163 HDD Crossing



Final Report for Supply Line 49-1 Replacement Project

Figure 8: Typical Congestion Along Abandonment Route Near Demarcation of Supply Line 49-25 and Supply Line 49-26



Final Report for Supply Line 49-1 Replacement Project

Figure 9: Western Tie-In Location in Old Town



Final Report for Supply Line 49-1 Replacement Project

D. Commissioning and Site Restoration

Commissioning activities include restoration of the site, final inspection and placement of the pipeline into service, transportation and disposal of hydrotested water and hazardous material, and site demobilization. Closeout activities include development of final drawings, finalization of a reconciliation package, and updates to company recordkeeping systems to reflect the completed scope of work.

IV. PROJECT COSTS

A. Cost Avoidance Actions

SDG&E exercised due diligence in the planning, design, and construction activities for this Project to minimize or avoid costs when prudent to do so. As discussed above, the Project Team conducted a site visit to identify and incorporate discernible site conditions into the engineering, design, and planning of the Project. Specific examples of cost avoidance actions taken on this Project are:

1. Engineering and Design: The rerouted alignment that was selected resulted in a number of cost avoidances:
 - a. Developed a design that eliminated two Caltrans highway crossings. This eliminated what would have been engineered crossings, such as jack and bore or HDD. The final design was able to utilize standard trenching, saving both time and costs.
 - b. Elimination of one regulator station avoided the cost of an additional tie-in and reduced future inspection and maintenance costs.
 - c. Relocation of the new regulator stations from private property to locations within existing franchises proved to be less costly.
 - d. Reduction in pipe diameter provided cost savings in construction activities, such as reduced welding times and smaller excavation volumes.
2. Materials:
 - a. Reduction in pipe diameter provided cost savings in material purchases.
 - b. The Project Team ordered the Project pipe in bulk.
3. Water Management: Reclaimed water for hydrotesting resulted in cost savings.

B. Cost Estimates

Once the primary elements of the project scope were confirmed and engineering, design, and planning activities were underway, SDG&E prepared an estimate of the Direct Costs of the Project in the amount of \$34,972,411, based on the preliminary design. The Project

Final Report for Supply Line 49-1 Replacement Project

Team considered the conditions known at the time to prepare the preliminary Direct Cost estimate. This estimate reflects the projected Labor, Material, and Services costs anticipated to be incurred to execute the Project.

SDG&E estimated the Indirect Costs of the Project based on the estimated Direct Costs and other project-related variables.

C. Actual Direct and Indirect Costs

Actual Direct Costs reflect the Labor, Material, and Services costs incurred to execute the Project. Actual Indirect Costs reflect costs for incremental overhead loaders in accordance with Company overhead allocation policies. The total loaded cost of the Project is \$64,339,516.

Table 4: Estimated and Actual Direct Costs and Variances⁹

Direct Costs (\$)	Estimate	Actuals	Delta Over/(Under)
Company Labor	1,956,845	1,445,057	(511,788)
Materials	3,661,030	2,042,840	(1,618,189)
Construction Contractor	19,483,451	27,255,530	7,772,079
Construction Management & Support	443,040	6,760,700	6,317,660
Environmental	1,047,973	1,291,216	243,243
Engineering & Design	3,124,271	8,012,948	4,888,678
Project Management & Services	1,217,935	1,720,346	502,411
ROW & Permits	1,123,499	1,331,902	208,403
GMA	2,914,368	3,951,634	1,037,266
Total Direct Costs	34,972,411	53,812,173	18,839,763

⁹ Values may not add to total due to rounding.

Final Report for Supply Line 49-1 Replacement Project

Table 5: Estimated and Actual Indirect Costs, Total Costs, and Variances¹⁰

Indirect Costs/Total Costs (\$)	Estimate	Actuals	Delta Over/(Under)
Overheads	4,945,737	6,944,146	1,998,409
AFUDC	1,248,977	3,094,557	1,845,580
Property Taxes	-	488,639	488,639
Total Indirect Costs	6,194,714	10,527,343	4,332,629
Total Direct Costs	34,972,411	53,812,173	18,839,763
Total Loaded Costs	41,167,125	64,339,516	23,172,391

¹⁰ Values may not add to total due to rounding.

Final Report for Supply Line 49-1 Replacement Project

D. Disallowances

For this replacement project, SoCalGas identified 3,215 feet of pipe as being installed after 1955 and lacking records that provide the minimum information necessary to demonstrate compliance with then-applicable industry standards or regulatory strength testing and recordkeeping requirements. Of the pipeline that was replaced, 3,215 feet of Phase 1A pipe is disallowed. Therefore, a \$1,040,938 reduction to ratebase was calculated by multiplying 0.609 miles¹¹ of pipe by \$1,709,257 million per mile, which was SoCalGas and SDG&E's system average cost of pressure testing at the time the pipeline was returned to service.

¹¹ Of the disallowed mileage, 0.454 miles are from Supply Line 49-25 and 0.155 miles from Supply Line 49-26.

V. CONCLUSION

SDG&E enhanced the safety of their integrated natural gas transmission system by prudently executing the Supply Line 49-1 Replacement Project. Through this Replacement Project, SDG&E successfully replaced 5.207 miles of pipeline and two MLVs in the City of San Diego. The total loaded cost of the Project is \$64,339,516.

SDG&E executed this Project prudently through analyzing all options to ultimately select a reroute that was safer, making the new pipeline more accessible and with fewer crossings under the highway, and responding prudently to unanticipated soil and water conditions which impacted construction. SDG&E adhered to all permit requirements for site restoration and completed work in accordance with permit requirements for traffic control and work hours that minimized impacts to the community.

SDG&E engaged in prudent cost avoidance efforts by locating the regulator stations on city property rather than private property, eliminating one regulator station from the system, sharing laydown yards, and using reclaimed water for hydrotesting. In addition, downsizing the pipe diameter provided cost savings in material costs as well as in construction activities, such as reduced welding times and smaller excavation volumes.

End of Supply Lines 49-1 Replacement Project Final Report

I. SUPPLY LINE 49-17 EAST REPLACEMENT PROJECT

A. Background and Summary

Supply Line 49-17 is a predominantly [REDACTED] diameter pipeline that runs approximately six and a half miles from San Diego to La Mesa, through heavily developed residential and commercial areas, as well as alongside and underneath Interstate Highway 8. The pipeline is primarily routed across a Class 3 location. This report describes the activities associated with Supply Line 49-17 East Replacement Project which consists of the replacement and reroute of 5.244 miles of pipeline from Alvarado Road and Fairmount Avenue, to the La Mesa Gate Station, the installation of four cased jack and bore crossings under water channels, Caltrans, and Metropolitan Transit System (MTS) rights of ways (ROWs), the installation of four new mainline valves (MLVs), and the grout fill of carrier and casing pipe in Caltrans and MTS ROWs. The specific attributes of this Project are detailed in Table 1 below. The total loaded cost of the Project is \$72,364,240.

Final Report for Supply Line 49-17 East Replacement Project

Table 1: General Project Information

Project Name		Supply Line 49-17 East		
Project Type	Replacement			
Length	5.244 miles			
Location	San Diego, La Mesa			
Class	3			
MAOP (<i>confidential</i>)	[REDACTED]			
Pipe Vintage	1948			
Construction Start	08/29/2016			
Construction Finish	12/20/2018			
Original Pipe Diameter (<i>confidential</i>)	[REDACTED]			
New Diameter (<i>confidential</i>)	[REDACTED]			
Original SMYS ¹ (<i>confidential</i>)	[REDACTED]			
New SMYS (<i>confidential</i>)	[REDACTED]			
Project Costs (\$)	Capital	O&M	Total	
Loaded Project Costs	72,364,240	-	72,364,240	
Disallowed Costs	1,606,360	-	1,606,360	

¹ Highest percentage of Specified Minimum Yield Strength (SMYS) of Category 4 Criteria pipe.

Final Report for Supply Line 49-17 East Replacement Project

B. Maps and Images

Figure 1: Overview Image of Supply Line 49-17 West and Supply Line 49-17 East Replacement Projects

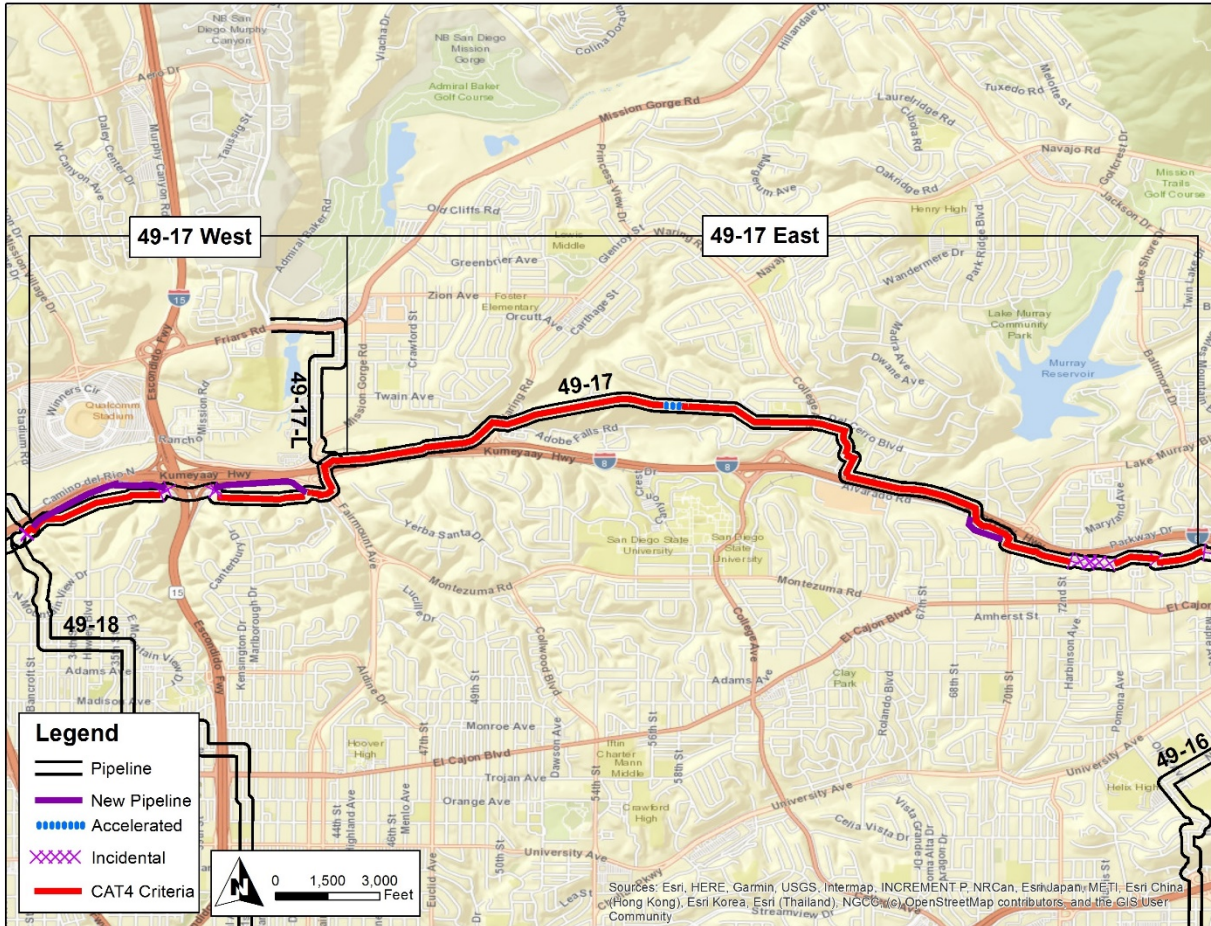

Final Report for Supply Line 49-17 East Replacement Project

Figure 2: Satellite Image of Supply Line 49-17 East Replacement Project

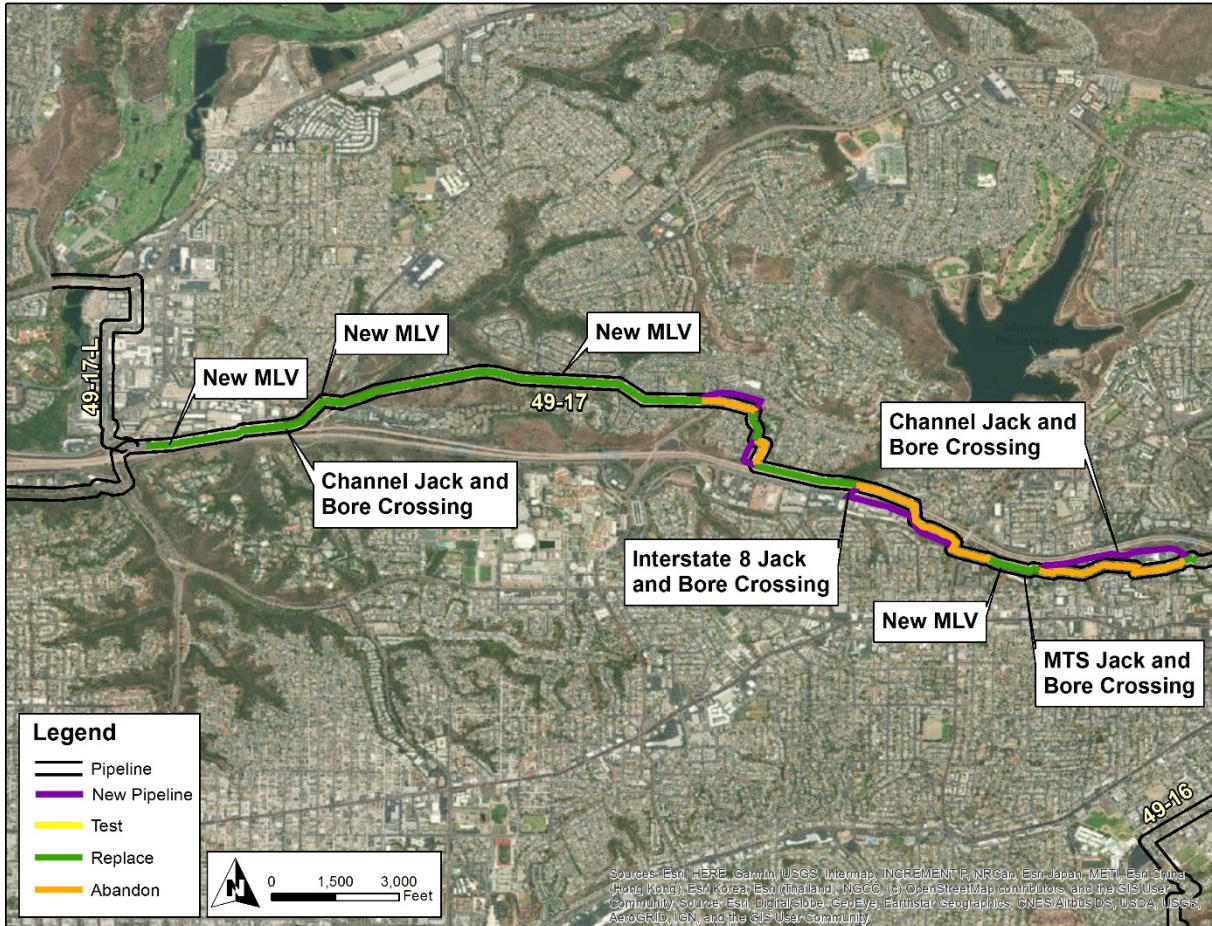

Final Report for Supply Line 49-17 East Replacement Project

Figure 3: Overview Map of Supply Line 49-17 East Replacement Project

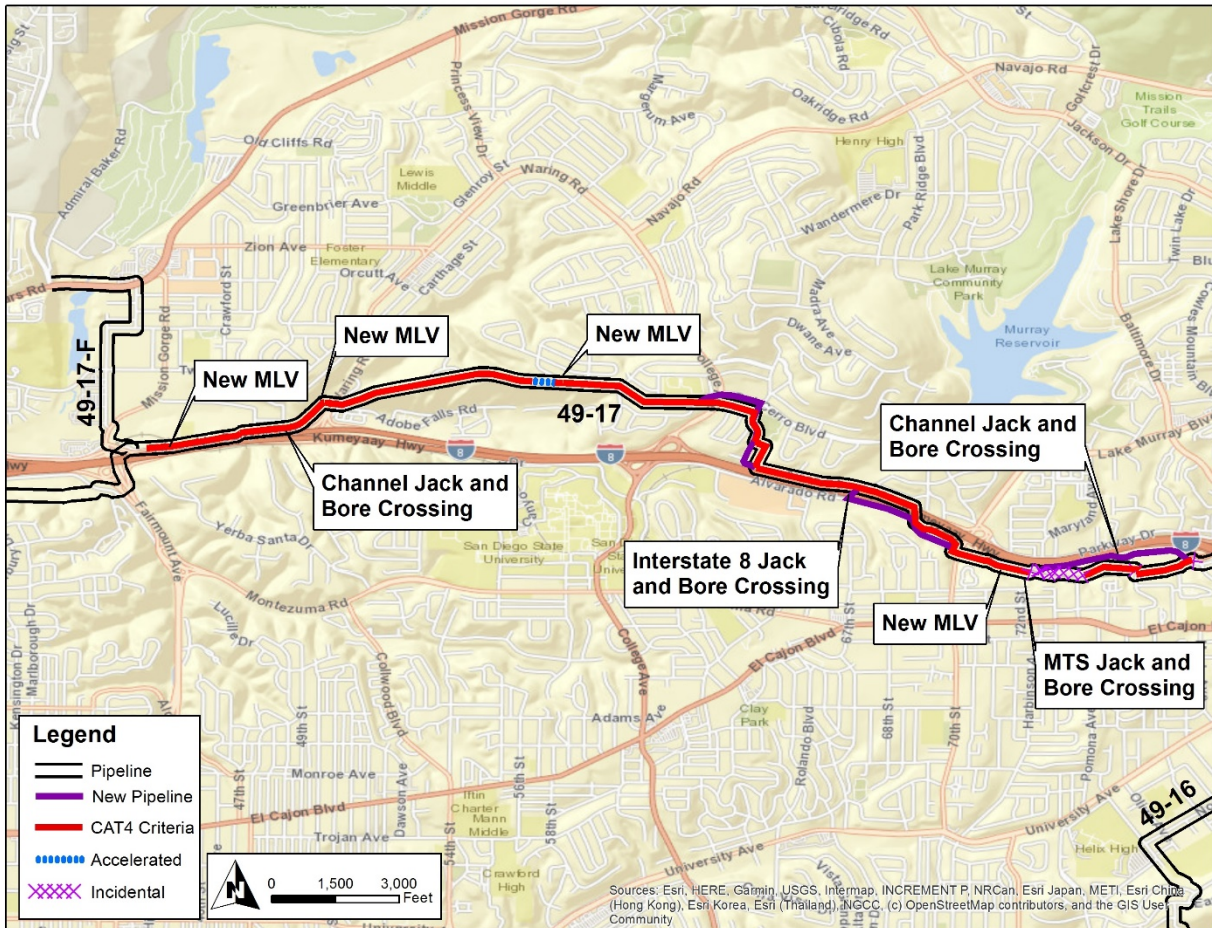

Final Report for Supply Line 49-17 East Replacement Project

Figure 4: Satellite Image of Jack and Bore Crossing Along Alvarado Canyon Road



Final Report for Supply Line 49-17 East Replacement Project

Figure 5: Satellite Image of MLV On Del Cerro Boulevard



Final Report for Supply Line 49-17 East Replacement Project

Figure 6: Satellite Image of Interstate 8 Jack and Bore Crossing

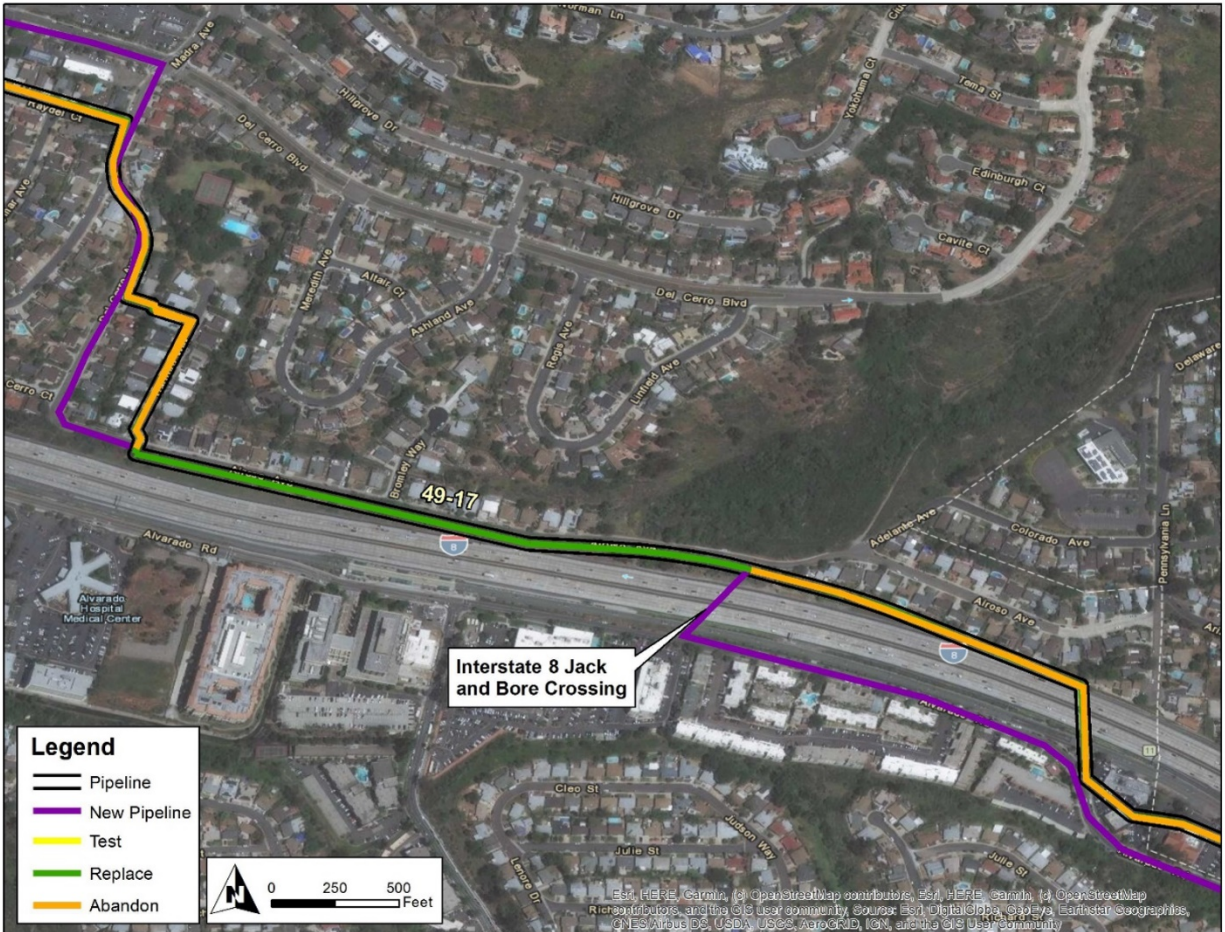

Final Report for Supply Line 49-17 East Replacement Project

Figure 7: Satellite Image of Jack and Bore Crossings Along Alvarado Road

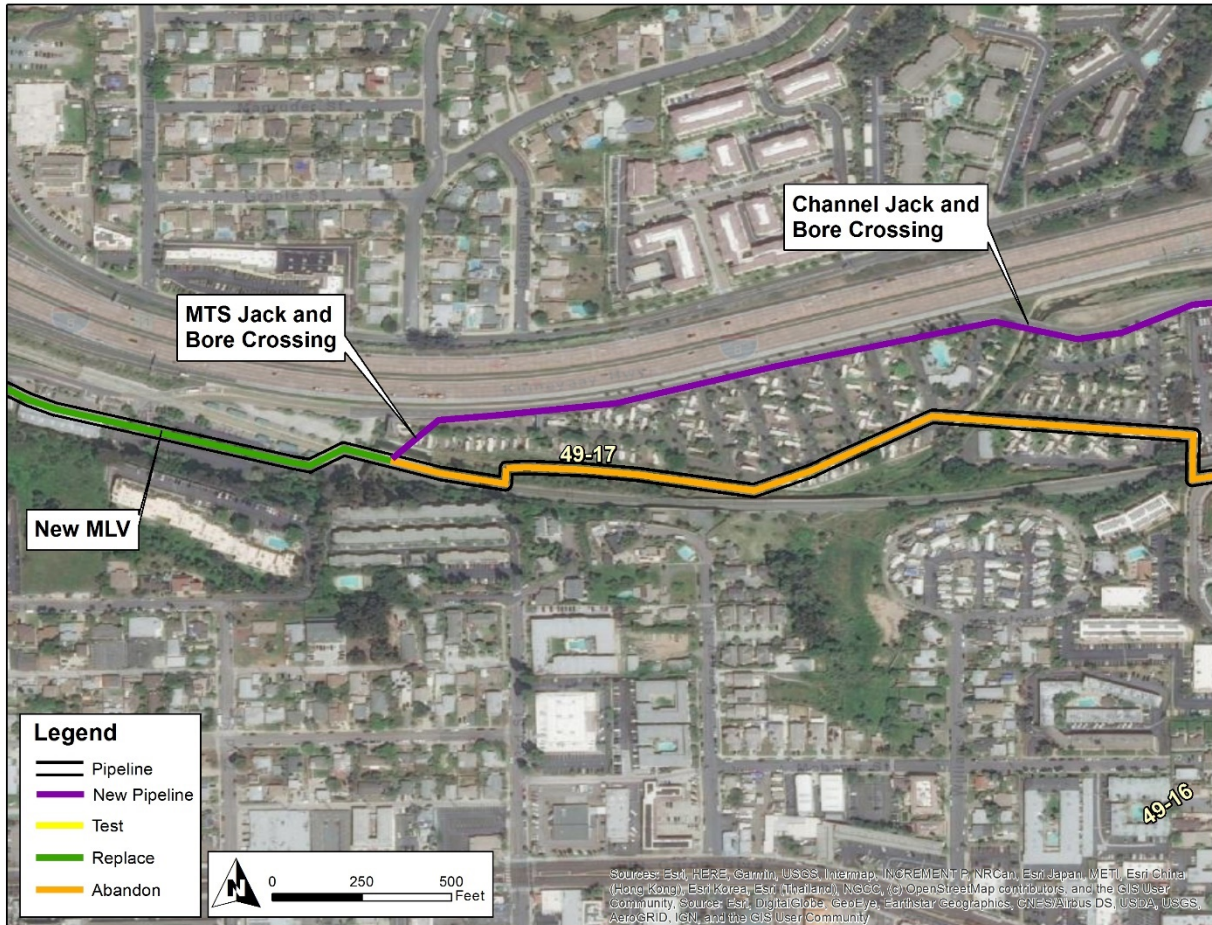

II. ENGINEERING, DESIGN, AND PLANNING

A. Project Scope

Table 2: Mileage Information (Supply Line 49-17 East Replacement Project)

	Criteria	Accelerated ²	Incidental	New	Total ³
Final Mileage	4.186 mi.	0.084 mi.	0.357 mi.	0.617 mi.	5.244 mi.
	22,103 ft.	443 ft.	1,886 ft.	3,258 ft.	27,690 ft.

SoCalGas and SDG&E presented a conceptual project scope in workpapers supporting the 2011 PSEP filing.⁴ Prior to initiating execution of the Project in 2015, SDG&E reviewed existing pipeline records to validate the scope of the Project. During the Engineering, Design, and Planning phase, SDG&E further refined the scope. This progression of the project scope is summarized as follows:

1. 2011 PSEP Filing: SoCalGas and SDG&E identified Supply Line 49-17 as a Phase 1A Replacement Project comprised of 5.259 miles of Category 4 Criteria pipe and 0.553 miles of Accelerated pipe.
2. Scope Validation: Through SDG&E’s scope validation activities, after the 2011 filing and before initiating execution of the Project, an additional 0.443 miles of Category 4 Criteria pipe was determined to be within the overall scope of the Supply Line 49-17 Project. For the reasons described below, this full scope of work associated with Supply Line 49-17 was divided into two projects: the Supply Line 49-17 East Replacement Project and the Supply Line 49-17 West Replacement Project. The

² Accelerated mileage includes Phase 2B pipe. Phase 2B includes pipelines without record of a pressure test to modern – Subpart J – standards (Phase 2B). The Accelerated mileage was included to realize efficiencies and to enhance project constructability.

³ Values may not add to total due to rounding.

⁴ See Amended PSEP of SoCalGas and SDG&E, submitted December 2, 2011, in R.11-02-019 and subsequently transferred to A.11-11-002.

Final Report for Supply Line 49-17 East Replacement Project

focus of this report is the Supply Line 49-17 East Replacement Project consisting of the pipeline mileage described in Table 2 above.

3. Engineering, Design, and Constructability:

- a. The Project Team determined that to minimize system capacity impacts and prevent service disruptions to customers, Supply Line 49-17 Replacement Project should be split into two Projects: Supply Line 49-17 East and Supply Line 49-17 West. Unless noted otherwise, information contained in this report is associated with the Supply Line 49-17 East Project.
- b. The Project Team utilized pressure control fittings (PCFs) at the regulator stations and customer taps to prevent service disruptions to customers.
- c. The Project Team rerouted portions of the replacement pipeline within the city franchise to avoid environmentally sensitive areas and to improve accessibility for routine maintenance and emergency response.
- d. The Project Team utilized four cased jack and bore crossings to go under water channels, Caltrans ROW, and MTS ROW.
- e. Accelerated and Incidental pipe was included for constructability.

4. Final Project Scope: The final Supply Line 49-17 East Replacement Project scope consists of the reroute and replacement of 5.244 miles of pipeline utilizing engineered crossings to address crossing at a water channel, the highway and MTS ROW, and the installation of four new MLVs. The Accelerated mileage consists of 443 feet of Phase 2B pipe and 0.357 miles of Incidental pipe.

B. Decision Tree Analysis

SDG&E performed a PSEP Decision Tree analysis of Supply Line 49-17 East and confirmed the project design should commence as a Replacement Project.

For pipeline segments longer than 1,000 feet in length, under the approved PSEP Decision Tree, SDG&E completes a preliminary review to determine whether SDG&E can manage customer service impacts if the pipeline segment is taken out of service for a period of two to six weeks to complete pressure testing. Where mitigation of customer

Final Report for Supply Line 49-17 East Replacement Project

impacts to remove the line from service for pressure testing is feasible, SDG&E compares the costs, constructability, risks, and benefits of pressure testing and replacement to determine whether pressure testing or replacement is the more prudent option.

Through this Decision Tree analysis, SDG&E identified replacement as the more prudent option. Key considerations that support SDG&E's determination to replace this segment include:

1. Shut-In Analysis: The Project Team completed a Request for Engineering Review (RER) analysis and concluded that due to the single feed servicing core customers, service could not be maintained during a single hydrostatic test. The Project Team utilized PCFs to prevent service disruptions to customers.
2. Customer Impacts: The Project Team identified approximately 44,000 customers along the Project route, including a cogeneration plant for a large university. The Project Team utilized PCFs to prevent service disruptions to customers.
3. Community Impacts: The location of this project is in a very busy commercial and residential area that required extensive traffic control measures and work hour restrictions to mitigate construction impact to business and residents along the construction route.
4. Piggability: Non-piggable.
5. Pipe Vintage: 1948.
6. Existing Pipe Attributes: The Project Team identified multiple existing non-piggable features such as bends, plug valves, and back-to-back elbows on the existing pipeline rendering the pipeline non-piggable.
7. Longseam Type: Unknown.
8. Longseam Repair History: The Project Team identified a leak along the longitudinal seam that was repaired in 1968.
9. Condition of Coating: The Project Team did not identify any issues.
10. History of Leaks: The Project Team identified a leak along the longitudinal seam that was repaired in 1968.

Final Report for Supply Line 49-17 East Replacement Project

C. Engineering, Design, and Planning Factors

SDG&E reviewed pipeline drawings and other information, contacted internal planning groups, communicated with external stakeholders, conducted survey activities, including reviewing public records and potholing of the area to confirm the presence of underground utilities and substructures, and completed a pre-design site walk. Key factors that influenced the engineering and design of the Project are as follows:

1. Reroute: The Project Team encountered a number of constraints along the preexisting route and determined that they could be mitigated by rerouting the pipeline alignment. In determining the rerouted alignment, the Project Team considered the following:
 - a. Due to the residential and commercial development that had occurred since the original installation of the pipeline in 1948, the Project Team determined that a rerouted alignment primarily within the city franchise which runs alongside Interstate 8 would improve accessibility for routine maintenance and emergency response.
 - b. A portion of Supply Line 49-17 East is aligned in hilly terrain in an existing 20 foot easement. The Project Team determined that there was not sufficient space to safely complete construction in these areas. The Project Team rerouted the pipeline into the city streets to provide adequate space for construction and to improve safety when accessing the pipeline for routine maintenance.
 - c. The Project also rerouted the pipeline to avoid disturbing environmentally sensitive areas.
2. Constructability: Based on the geotechnical evaluation, which identified large cobble rock and possible liquefaction, the Project Team determined that a [REDACTED] cased jack and bore crossings was necessary under the water channels, Caltrans ROW, and MTS ROW.

Final Report for Supply Line 49-17 East Replacement Project

3. Shut-In Analysis: The Project Team completed an RER analysis and concluded the line could not be shut in and that customer service would need to be maintained through alternate means.
4. Customer Impact: Per the RER, approximately 44,000 customers and a cogeneration plant for a large university are served off this pipeline. The Project Team utilized PCFs to prevent service distributions to customers.
5. Schedule Coordination: The Project Team coordinated the tie-in with the large university cogeneration plant to prevent any disruptions to their service.
6. Community Impact: The location of this project is in a very busy commercial and residential area that required extensive traffic control measures and work hour restrictions to mitigate construction impact to business and residents along the construction route.
7. Permit Conditions:
 - a. The Project Team obtained encroachment and traffic control permits from Caltrans for construction activities occurring in their ROW.
 - b. The Project Team filled all abandoned casing and carrier pipe with grout within the Caltrans and MTS ROWs per the permit requirements.
 - c. The Project Team obtained an encroachment permit from the MTS for activities occurring in their ROW and when accessing areas beneath the rail overpasses.
 - d. The Project Team obtained encroachment and traffic control permits from the City of San Diego for activities occurring in their ROW. The Project Team also obtained a noise permit from the City of San Diego for night work.
 - e. The Project Team obtained encroachment and traffic control permits from the City of La Mesa for construction activities occurring within their ROW.
 - f. The Project Team obtained groundwater permits to discharge any groundwater encountered during construction.
8. Environmental:
 - a. The Project Team determined that ground water was likely to affect construction in some areas of the new alignment. To mitigate potential impacts, the Project

Final Report for Supply Line 49-17 East Replacement Project

- Team obtained discharge permits to dispose of any groundwater encountered during construction.
- b. The Project Team utilized reclaimed water for the hydrotest of the new pipeline.
 - c. The Project Team identified endangered bird and plant species located along the pipeline route near San Diego City Hill between Waring Road and Del Cerro Boulevard. An environmental monitor was onsite during construction to ensure compliance with environmental requirements was maintained.
 - d. The Project Team determined that the pipe coating on the existing pipeline likely contained asbestos and planned for abatement activities wherever existing pipe was to be exposed.
9. Substructures: The ground penetrating radar (GPR) report revealed and confirmed substructures. The Project Team identified multiple substructures along the new alignment. The design of the new pipeline avoided these substructures.
10. Land Use:
- a. The City of San Diego Parks and Recreation approved only a 20 foot construction easement rather than the requested 50 foot construction easement, reducing construction productivity due to working in limited area.
 - b. The Project Team shared a laydown yard with the PSEP Supply Line 49-17 West Replacement Project and the PSEP La Mesa Gate Replacement Project.
11. Valves: The Project Team installed four MLVs on the new pipeline alignment to replace the MLVs on the abandoned pipeline.

D. Scope Changes

Through engineering, design, and planning activities, SDG&E determined that changes in scope were appropriate to enhance the design of the Project and address engineering factors. As a result, the scope of work that the preliminary cost estimate was based on does not fully reflect the final scope.

Final Report for Supply Line 49-17 East Replacement Project

1. The Project Team redesigned the location of a bore crossing from Interstate 8 to a franchise location within the City of San Diego to avoid the cost of acquiring a private easement.
2. The Project Team executed the design and construction of the Project in the order that permits were being issued and/or reissued due to changes in design during construction. This allowed the Project Team to initiate construction as soon as construction risks were identified, mitigation measures were in place and all necessary permits were obtained. As construction proceeded, unanticipated conditions resulted in delays and redesigns.
 - a. MTS permitting was delayed for 12 months for the grout filling of the abandoned pipeline for three locations within MTS ROW. This impacted the Construction Contractor ability to completely demobilize following the completion of Project.
 - b. City of La Mesa permitting was delayed 10 months from the planned three-month period to include late changes and requirements to include recessed plating of trenches, paving over areas where new pipe was not installed, and curb to curb paving.

III. CONSTRUCTION

A. Construction Contractor Selection

The Project Team prepared an initial cost estimate based on the preliminary design. Following completion of the engineering, design, and planning activities described above, SDG&E entered a competitive bidding process to select a construction contractor, that included the updated design described in the discussion of notable Scope Changes above. SDG&E awarded the construction contract to the bidder that best met the selection criteria for this project.

1. SDG&E’s Preliminary Construction Cost Estimate (confidential): SDG&E’s preliminary cost estimate for construction was [REDACTED].
2. Construction Contractor’s Bid (confidential): The Construction Contractor’s bid was [REDACTED], that was [REDACTED] than SDG&E’s preliminary cost estimate for construction.

B. Construction Schedule

Table 3: Construction Timeline

Construction Start Date	08/29/2016
Construction Completion Date ⁵	12/20/2018
NOP Date	02/21/2017

⁵ Construction finish duration includes abandonment site restoration related activities.

Final Report for Supply Line 49-17 East Replacement Project

C. Changes During Construction

The conditions summarized below were encountered during construction. Activities to address or mitigate these conditions resulted in approximately \$7,890,000 in change orders.

1. Constructability Issues:

- a. Due to unanticipated challenging field conditions, it became necessary to redesign a jack and bore crossing due to space constraints. During the boring operations, the construction team encountered unanticipated oversized cobble, unstable soil conditions, and groundwater, impacting productivity resulting in a change to a hand mining operation to work through the obstructions and limitations of the jack and bore equipment.
- b. During excavation, construction crews determined that an existing [REDACTED] gas distribution line would interfere with the installation of the planned bore pit for a channel crossing. The Project Team relocated a bore pit to avoid the conflicting utility.
- c. The Project Team relocated a bore to avoid previously unidentified utilities and substructures and MTS crossing which conflicted with the planned bore and to avoid impacting a bus route.

2. Field Design Changes:

- a. Caltrans and MTS required that SDG&E remove the existing [REDACTED] carrier pipe from the existing pipe casing prior to filling the casing with grout.
- b. Following the post-completion hydrotest, the Project Team replaced two new [REDACTED] MLVs due to concerns that the valves suffered damaged during the hydrotest. The replacement of the valves required additional excavation, removal of the valves, fabrication, assisting with the nitrogen pressure test of the replacement valves, backfill, and paving.

Final Report for Supply Line 49-17 East Replacement Project

- c. SDG&E requested that the construction contractor remove line markers, valve cans, vaults, regulator set, meter sets, pipeline marker disc, and temporary fence from the ROW where the existing pipeline was being abandoned.
 - d. The Project Team reversed the direction of one of the bore pits due to space constraints. The new launching pit required additional shoring and encountered unanticipated groundwater. During boring operations, due to the need to continuously mitigate groundwater, work proceeded on a 24 hour a day, 7 day a week schedule and included unanticipated hand mining operations to install a [REDACTED] casing.
 - e. During excavation, the Project Team encountered some previously unidentified substructures. The Project Team relocated and redesigned one of the new MLVs and the associated piping in order to maintain an uninterrupted feed to a cogeneration plant for a large university. This work included the removal of the existing MLV, the installation of the new MLV, the removal and replacement of an existing [REDACTED] valve, the installation of PCF fittings, and the necessary site restoration.
 - f. During construction, the Project Team determined that an existing storm drain was at a shallower depth than anticipated. The Project Team altered the depth of a portion of the pipeline to go below a storm drain in order to maintain the necessary separation between the pipeline and the storm drain and to maintain the necessary pipeline depth.
3. Site Restoration: The City of La Mesa required additional paving restoration following the replacement of multiple valves within the city.
4. Traffic: Additional flaggers were required at each driveway, intersection, and obstructed line of sign along Alvarado Road and Alvarado Canyon Road per the approved traffic control plans.

Final Report for Supply Line 49-17 East Replacement Project

Figure 8: Preheating of Casing Pipe Between Welding Passes



Final Report for Supply Line 49-17 East Replacement Project

Figure 9: Groundwater Removal from Trench



Final Report for Supply Line 49-17 East Replacement Project

Figure 10: Saw Cutting Operations



Final Report for Supply Line 49-17 East Replacement Project

D. Commissioning and Site Restoration

Commissioning activities include restoration of the site, final inspection and placement of the pipeline back into service, transportation and disposal of hydrotest water and hazardous material, and site demobilization. Closeout activities include development of final drawings, finalization of a reconciliation package, and updates to company recordkeeping systems to reflect the completed scope of work.

IV. PROJECT COSTS

A. Cost Avoidance Actions

SDG&E exercised due diligence in the planning, design, and construction activities for this project to minimize or avoid costs when prudent to do so. As discussed above, the Project Team conducted a site visit to identify and incorporate discernible site conditions into the engineering, design, and planning of the Project. Specific examples of cost avoidance actions taken on this project are:

1. Land Use:
 - a. The Project Team shared a laydown yard with the PSEP Supply Line 49-17 West Replacement Project and the PSEP La Mesa Gate Replacement Project.
 - b. The Project Team relocated a jack and bore pit from private property to City franchise to reduce land acquisition costs.
2. Water Management: The Project Team filtered and discharged groundwater to the sewer onsite rather than hauling offsite for disposal.
3. Construction Execution:
 - a. The Project Team utilized additional field bends to minimize the material and weld costs.
 - b. The Project Team redesigned the four jack and bore designs to reduce the launching and receiving pit depths.

Final Report for Supply Line 49-17 East Replacement Project

B. Cost Estimate

Once the primary elements of the project scope were confirmed and engineering, design, and planning activities were underway, SDG&E prepared an estimate of the Direct Costs of the Project in the amount of \$58,214,864, based on the preliminary design. The Project Team considered the conditions known at the time to prepare the preliminary Direct Cost estimate. This estimate reflects the projected Labor, Material, and Services costs anticipated to be incurred to execute the Project.

SDG&E estimated Indirect Costs of the Project based on the estimated Direct Costs and other project-related variables.

C. Actual Direct and Indirect Costs

Actual Direct Costs reflect the Labor, Material, and Services costs incurred to execute the Project. Actual Indirect Costs reflect costs for incremental overhead loaders in accordance with Company overhead allocation policies. The total loaded cost of the Project is \$72,364,240.

Final Report for Supply Line 49-17 East Replacement Project

Table 4: Estimated and Actual Direct Costs and Variances⁶

Direct Costs (\$)	Estimate	Actuals	Delta Over/(Under)
Company Labor	1,377,491	500,222	(877,269)
Materials	5,580,745	2,559,097	(3,021,647)
Construction Contractor	31,084,374	40,219,091	9,134,717
Construction Management & Support	2,431,012	5,065,487	2,634,475
Environmental	2,921,054	3,058,188	137,134
Engineering & Design	6,059,295	5,808,426	(250,869)
Project Management & Services	1,960,884	1,196,695	(764,189)
ROW & Permits	1,948,770	1,017,277	(841,493)
GMA	4,851,239	3,826,194	(1,025,045)
Total Direct Costs	58,214,864	63,340,678	5,125,814

Table 5: Estimated and Actual Indirect Costs, Total Costs, and Variances⁷

Indirect Costs/Total Costs (\$)	Estimate	Actuals	Delta Over/(Under)
Overheads	6,779,458	4,843,259	(1,936,199)
AFUDC	2,581,551	3,615,291	1,033,740
Property Taxes	0	565,013	565,013
Total Indirect Costs	9,361,009	9,023,563	(337,447)
Total Direct Costs	58,214,864	63,340,678	5,125,814
Total Loaded Costs	67,575,872	72,364,240	4,788,367

⁶ Values may not add to total due to rounding.

⁷ Ibid.

Final Report for Supply Line 49-17 East Replacement Project

E. Disallowance

For this replacement project, SDG&E identified 4,929 feet of pipe as being installed after 1955 and lacking records that provide the minimum information necessary to demonstrate compliance with then-applicable industry standards or regulatory strength testing and recordkeeping requirements. Of the pipeline that was replaced, 4,929 feet of Phase 1A pipe is disallowed. Therefore, a \$1,606,360 reduction to ratebase was calculated by multiplying 0.9398 miles of pipe by \$1,709,257 million per mile, which was SoCalGas and SDG&E's system average cost of pressure testing at the time the pipeline was returned to service.

V. CONCLUSION

SDG&E enhanced the safety of its natural gas transmission system by prudently executing the Supply Line 49-17 East Replacement Project. Through this Replacement Project, SDG&E successfully replaced 5.244 miles of pipeline and approximately 378 feet of jack and bore in the City of San Diego. The total loaded cost of the Project is \$72,364,240.

SDG&E executed this project prudently through rerouting within city franchise to improve accessibility to the pipeline, minimize impact to private landowners and to avoid environmentally sensitive areas. SDG&E adhered to all permit requirements for site restoration and completed work in accordance with permit requirements for traffic control and work hours that minimized impacts to the community.

SDG&E engaged in prudent cost avoidance efforts by sharing laydown yards with other projects, utilizing reclaimed water for the hydrotest, locally treating groundwater so it could be disposed of in the nearby sewer system, minimizing the use of [REDACTED] fittings in construction to avoid additional materials and welding costs, and utilizing bulk ordered pipe provided volume pricing for the [REDACTED] pipe.

End of Supply Line 49-17 East Replacement Project Final Report

I. SUPPLY LINE 49-17 WEST REPLACEMENT PROJECT

A. Background and Summary

Supply Line 49-17 is a predominantly [REDACTED] diameter pipeline that runs approximately six and a half miles from San Diego to La Mesa, through heavily developed residential and commercial areas, as well as alongside Interstate Highway 8. The pipeline is primarily routed across a Class 3 location. This report describes the activities associated with Supply Line 49-17 West Replacement Project, which consists of the partial reroute and replacement of 1.671 miles of pipeline and one cased jack and bore under a box culvert. The pipeline alignment was rerouted to be within city franchise to improve accessibility for routine maintenance, emergency response, and to avoid environmentally sensitive areas. The specific attributes of this Project are detailed in Table 1 below. The total loaded cost of the Project is \$37,512,409.

Final Report for Supply Line 49-17 West Replacement Project

Table 1: General Project Information

Project Name		Supply Line 49-17 West		
Project Type	Replacement			
Length	1.671 miles			
Location	San Diego			
Class	3			
MAOP (<i>confidential</i>)	[REDACTED]			
Pipe Vintage	1948			
Construction Start	10/15/2014			
Construction Finish ¹	06/15/2018			
Original Pipe Diameter (<i>confidential</i>)	[REDACTED]			
New Diameter (<i>confidential</i>)	[REDACTED]			
Original SMYS ² (<i>confidential</i>)	[REDACTED]			
New SMYS (<i>confidential</i>)	[REDACTED]			
Project Costs (\$)	Capital	O&M	Total	
Loaded Project Costs	37,512,409	-	37,512,409	
Disallowed Costs	550,381	-	550,381	

¹ Construction activity was staggered due to delays in obtaining permits. For more details see Engineering, Design, and Planning.

² Highest percentage of Specified Minimum Yield Strength (SMYS) of Category 4 Criteria pipe.

Final Report for Supply Line 49-17 West Replacement Project

A. Maps and Images

Figure 1: Overview Image of Supply Line 49-17 West and Supply Line 49-17 East Replacement Projects

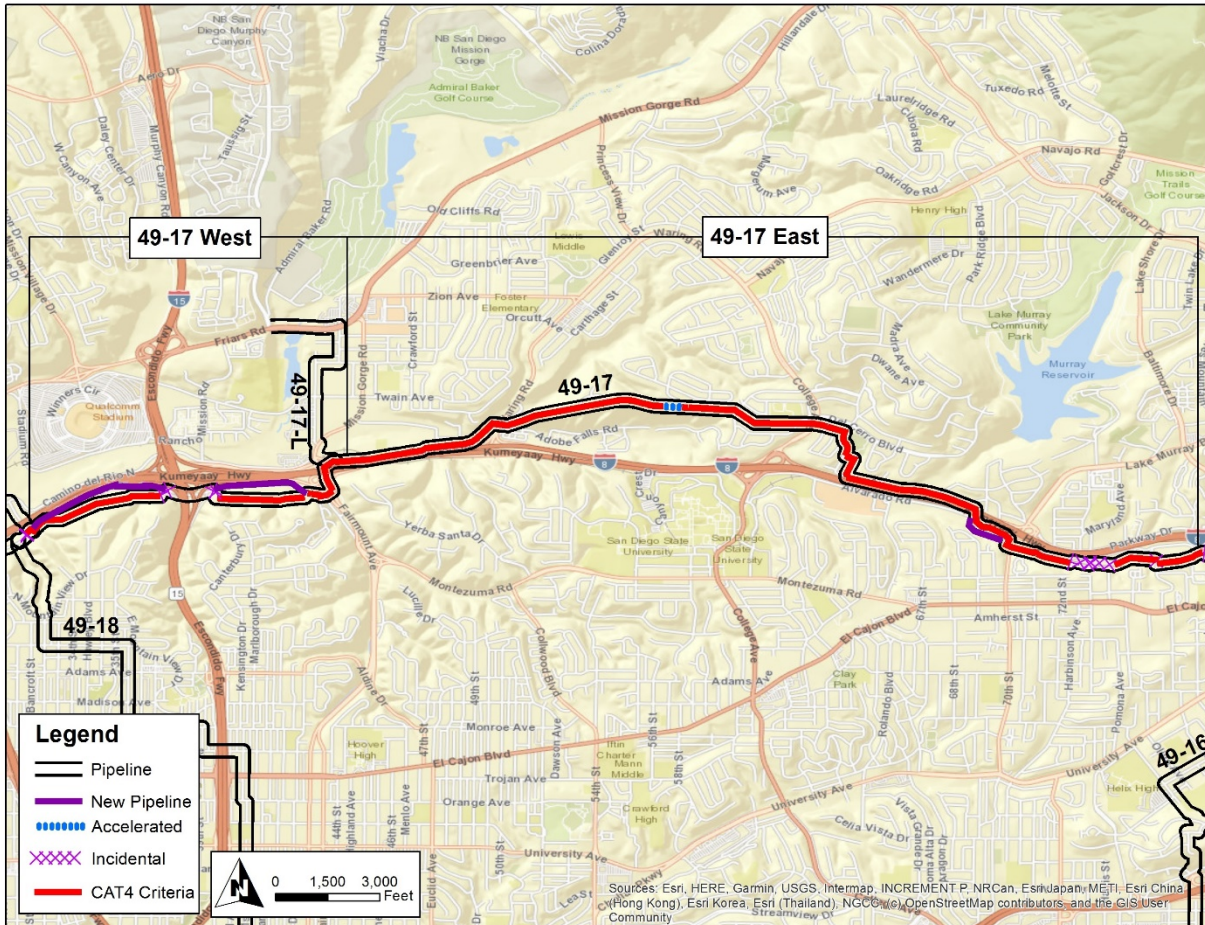

Final Report for Supply Line 49-17 West Replacement Project

Figure 3: Overview Map of Supply Line 49-17 West Replacement Project

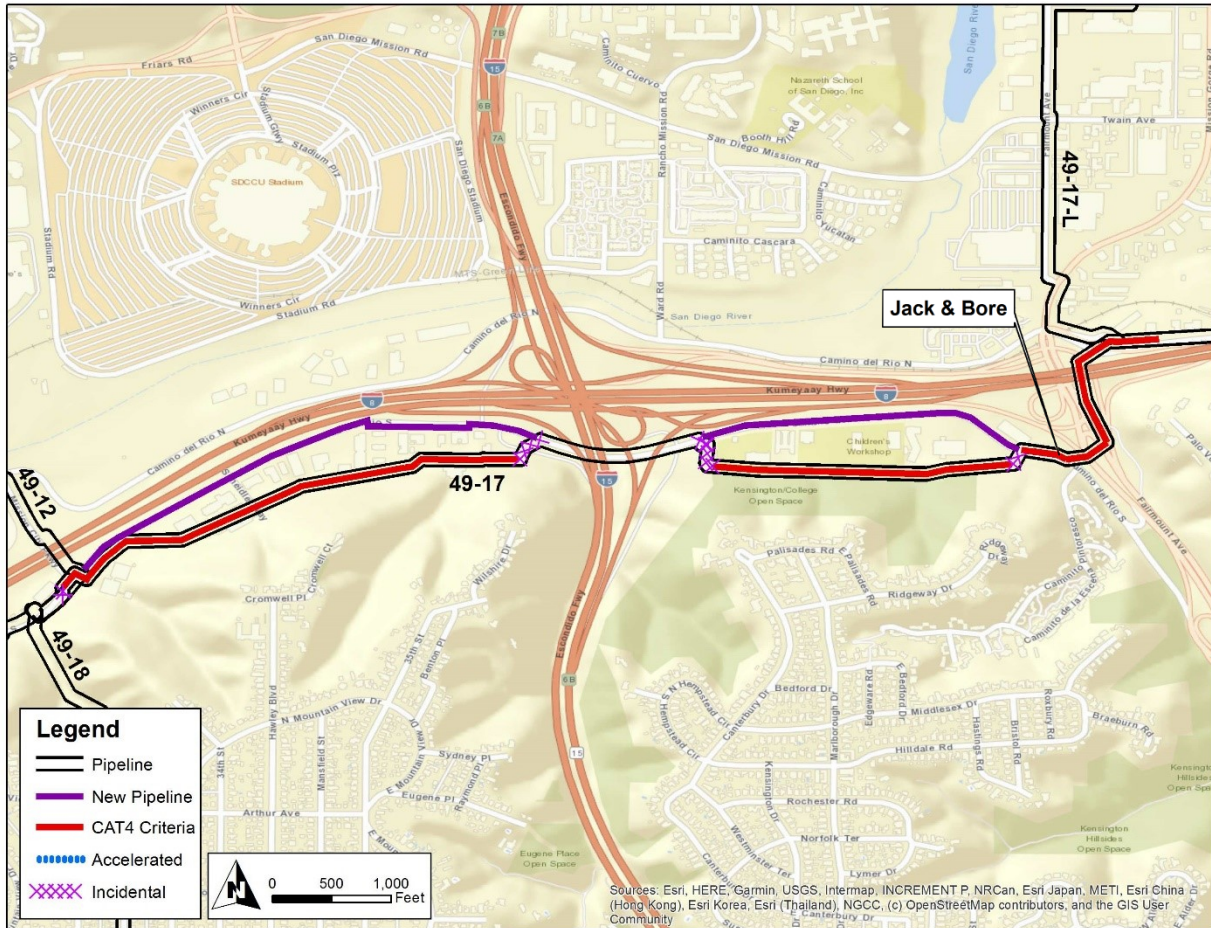

II. ENGINEERING, DESIGN, AND PLANNING

A. Project Scope

Table 2: Mileage Information (Supply Line 49-17 West Replacement Project)

	Criteria	Accelerated	Incidental	New	Total ³
Final Mileage	1.494 mi.	0 mi.	0.168 mi.	0.009 mi.	1.671 mi.
	7,891 ft.	0 ft.	888 ft.	47 ft.	8,826 ft.

SoCalGas and SDG&E presented a conceptual project scope in workpapers supporting the 2011 PSEP filing.⁴ Prior to initiating execution of the Project in 2014, SDG&E reviewed existing pipeline records to validate the scope of the Project. During the Engineering, Design, and Planning phase, SDG&E further refined the scope. This progression of the project scope is summarized as follows:

1. 2011 PSEP Filing: SoCalGas and SDG&E identified Supply Line 49-17 as a Phase 1A Replacement Project comprised of 5.259 miles of Category 4 Criteria pipe and 0.553 miles of Accelerated pipe.
2. Scope Validation: Through SDG&E’s scope validation activities, after the 2011 filing and before initiating execution of the Project, an additional 0.443 miles of Category 4 Criteria pipe was determined to be within the overall scope of the Supply Line 49-17 Project. For the reasons described below, this full scope of work associated with Supply Line 49-17 was divided into two projects: The Supply Line 49-17 East Replacement Project and the Supply Line 49-17 West Replacement Project. The focus of this report is the Supply Line 49-17 West Replacement Project consisting of pipeline mileage as described in Table 2 above.

³ Values may not add to total due to rounding.

⁴ See Amended PSEP of SoCalGas and SDG&E, submitted December 2, 2011, in R.11-02-019 and subsequently transferred to A.11-11-002.

Final Report for Supply Line 49-17 West Replacement Project

3. Engineering, Design, and Constructability:

- a. The Project Team determined that to minimize system capacity impacts and customer service disruption, Supply Line 49-17 Replacement Project should be split into two Projects, Supply Line 49-17 East and Supply Line 49-17 West. Unless noted otherwise, information contained in this report is associated with the Supply Line 49-17 West Project.
- b. The Project Team utilized pressure control fittings (PCFs) at the regulator stations and customer taps to prevent customer service disruption.
- c. The Project included a partial reroute and replacement within city franchise to improve accessibility for routine maintenance, emergency response, and to avoid environmentally sensitive areas.
- d. The Project Team initiated construction at locations with minimal permitting requirements to sequence construction efficiently to complete this PSEP work as soon as practicable.
- e. Incidental mileage was the result of the rerouted alignment.

4. Final Project Scope: The final Supply Line 49-17 West Replacement Project scope consists of the reroute and replacement of 1.671 miles of pipeline. The Incidental mileage consists of 888 feet of pipe.

B. Decision Tree Analysis

SDG&E performed a PSEP Decision Tree analysis of Supply Line 49-17 West and confirmed the project design should commence as a Replacement Project.

For pipeline segments longer than 1,000 feet in length, under the approved PSEP Decision Tree, SDG&E completes a preliminary review to determine whether SDG&E can manage customer service impacts if the pipeline segment is taken out of service for a period of two to six weeks to complete pressure testing. Where mitigation of customer impacts to remove the line from service for pressure testing is feasible, SDG&E compares the costs, constructability, risks, and benefits of pressure testing and replacement to determine whether pressure testing or replacement is the more prudent option.

Final Report for Supply Line 49-17 West Replacement Project

Through this Decision Tree analysis, SDG&E identified replacement as the more prudent option. Key considerations that support SDG&E's determination to replace this segment include:

1. Shut-In Analysis: The Project Team completed a Request for Engineering Review (RER) analysis and concluded the line could not be shut-in. The Project Team sequenced the tie-in segments utilizing PCFs to prevent service disruptions to customers.
2. Customer Impacts: The Project Team identified approximately 700 customers along the Project route. The Project Team utilized PCFs to prevent service disruptions to customers.
3. Piggability: Non-piggable.
4. Pipe Vintage: 1948.
5. Existing Pipe Attributes: The project Team identified wrinkle bends and back to back fittings on the existing pipeline rendering the pipeline non-piggable.
6. Longseam Type: Unknown and SAW.
7. Longseam Repair History: The Project Team identified a leak along the longitudinal seam that was repaired in 1968.
8. Condition of Coating: The Project Team did not identify any issues.
9. History of Leaks: The Project Team identified a leak along the longitudinal seam that was repaired in 1968.

C. Engineering, Design, and Planning Factors

SDG&E reviewed pipeline drawings and other information, contacted internal planning groups, communicated with external stakeholders, conducted survey activities, including reviewing public records and potholing of the area to confirm the presence of underground

Final Report for Supply Line 49-17 West Replacement Project

utilities and substructures, and completed a pre-design site walk. Key factors that influenced the engineering and design of the Project are as follows:

1. Reroute: The Project Team encountered a number of constraints along the preexisting route and determined that they could be mitigated by rerouting the pipeline alignment. In determining the rerouted alignment, the Project Team considered the following:
 - a. Due to the residential and commercial development that had occurred since the original installation of the pipeline in 1948, the Project Team determined that a rerouted alignment primarily within the city franchise which runs alongside Interstate 8 would improve accessibility for routine maintenance and emergency response.
 - b. A portion of Supply Line 49-17 East is aligned in hilly terrain in an existing 20 foot easement. The Project Team determined that there was not sufficient space to safely complete construction in these areas. The Project Team rerouted the pipeline into the city streets to provide adequate space for construction and to improve safety when accessing the pipeline for routine maintenance.
 - c. The Project also rerouted the pipeline to avoid disturbing environmentally sensitive areas.
2. Constructability:
 - a. The Project Team initiated construction at locations with short permitting lead times to sequence construction.
 - b. A geotechnical report identified the presence of large cobble rock and the possibility of liquefaction.
 - c. The Project Team determined that utilization of [REDACTED] cased jack and bore crossings were required under a concrete box culvert located between Camino Del Rio South and Fairmount Avenue.

Final Report for Supply Line 49-17 West Replacement Project

3. Shut-In Analysis: As discussed above, the Project Team completed an RER analysis that concluded the line could not be shut-in and customer service would need to be maintained through utilizing PCFs.
4. Customer Impact: Per the RER, approximately 700 customers along the Project route are supplied from this pipeline and have no other source of gas. The Project Team utilized PCFs to prevent service disruptions to customers.
5. Community Impact:
 - a. The location of his project is in a very busy commercial and residential area that required extensive traffic control measures to mitigate construction impact to business and residents along the construction route.
 - b. The Project Team performed night work during at the intersection of Camino Del Rio and Fairmont Avenue to minimize the impact to traffic.
6. Permit Conditions:
 - a. The Project Team obtained an encroachment permits, and traffic control permits from Caltrans.
 - b. The Project Team obtained a Water Pollution Control Permit.
 - c. The Project Team obtained an encroachment permit, traffic control permits, noise variance permits, vegetation removal permits, and a Water Pollution Control Permit from the City of San Diego.
7. Environmental:
 - a. The Project Team identified environmentally sensitive vegetation located south of the pipeline route.
 - b. The Project Team determined that the pipe coating on the existing pipeline likely contained asbestos and planned for abatement activities wherever existing pipeline was to be exposed.
8. Substructures: The Project Team identified a large box culvert during the detailed design phase. The Project Team utilized the jack and bore construction method to avoid the box culvert.

Final Report for Supply Line 49-17 West Replacement Project

D. Scope Changes

SoCalGas and SDG&E did not make any notable scope changes during detailed design.

III. CONSTRUCTION

A. Construction Contractor Selection

The Project Team prepared an initial cost estimate based on the preliminary design for Supply Line 49-17 West. Following completion of the more detailed engineering, design, and planning activities described above, the Project Team evaluated the scope of the projects and determined that construction would be executed by two Contractors with one completing the Caltrans activities and another Contractor completing all of the non-Caltrans activities. The Contractor executing the Caltrans work was selected through a competitive bid and the Contractor executing the non-Caltrans work was selected through the Performance Partner program. The Project Team awarded Caltrans work to the bidder that best met the selection criteria for that portion of this project.

1. SDG&E’s Preliminary Construction Cost Estimate (confidential): SDG&E’s preliminary cost estimate for construction was [REDACTED]
2. Construction Contractor’s Estimate (confidential): The Construction Contractor’s bid for the Caltrans work and the Performance Partners estimate for the non-Caltrans resulted in a total combined cost of [REDACTED]. That was [REDACTED] than SDG&E’s preliminary cost estimate for construction.

B. Construction Schedule

Table 3: Construction Timeline

Construction Start Date	10/15/2014
Construction Completion Date ⁵	06/15/2018
NOP Date	08/29/2017

⁵ Construction finish duration includes abandonment site restoration related activities.

Final Report for Supply Line 49-17 West Replacement Project

C. Changes During Construction

The conditions summarized below were encountered during construction. Activities to address or mitigate these conditions resulted in approximately \$883,000 in change orders.

1. Traffic: Caltrans required additional traffic control, beyond what was anticipated, for the closure of the Interstate 8 ramps.
2. Substructures: The Project Team redesigned the bore pits along Camino Del Rio South due to the box culvert at the site being larger than anticipated. This resulted in a longer bore design, additional shoring and traffic control.
3. Work Hours:
 - a. Additional hours were required for the post completion hydrotest on 12/11/2014 and 12/12/2014, and tie-in on 12/13/2014. The original TPE assumed 12 hour work days.
 - b. Additional hours were required for the post completion hydrotest test on 12/06/2014 and dewatering 12/07/2014. The original TPE assumed 12 hour work days and no Sunday work.
4. Site Conditions: The Project Team encountered a concrete treated base during a portion of the excavation, necessitating the use of a hydraulic backhoe breaker to excavate the trench.

Final Report for Supply Line 49-17 West Replacement Project

Figure 4: Route Along Fairmount Avenue Near Interstate 8



Final Report for Supply Line 49-17 West Replacement Project

Figure 5: Eastern Tie-In Location Near Camino Del Rio and Fairmount Avenue



Final Report for Supply Line 49-17 West Replacement Project

Figure 6: Tie-In Location Near Interstate 8 and Interstate 15 Interchange



Final Report for Supply Line 49-17 West Replacement Project

Figure 7: Pipe With Field Bend



Final Report for Supply Line 49-17 West Replacement Project

Figure 8: Holiday Testing of a Coated Weld



Final Report for Supply Line 49-17 West Replacement Project

Figure 9: Traffic Control Along Camino Del Rio South



Final Report for Supply Line 49-17 West Replacement Project

Figure 10: Pig Launcher for Post Completion Hydrotest



Final Report for Supply Line 49-17 West Replacement Project

D. Commissioning and Site Restoration

Commissioning activities include restoration of the site, final inspection and placement of the pipeline back into service, transportation and disposal of hydrotest water and hazardous material, and site demobilization. Closeout activities include development of final drawings, finalization of a reconciliation package, and updates to company recordkeeping systems to reflect the completed scope of work.

IV. PROJECT COSTS

A. Cost Avoidance Actions

SDG&E exercised due diligence in the planning, design, and construction activities for this project to minimize or avoid costs when prudent to do so. As discussed above, the Project Team conducted a site visit to identify and incorporate discernible site conditions into the engineering, design, and planning of the Project. Specific examples of cost avoidance actions taken on this project are:

1. Materials: The Project Team ordered [REDACTED] piping in bulk.
2. Future Maintenance: The new pipeline was routed within city franchise and out of hilly terrain to make future maintenance less burdensome on the community, and the environment by avoiding the need to maintain an access road for pipeline patrols.

B. Cost Estimate

Once the primary elements of the project scope were confirmed and engineering, design, and planning activities were underway, SDG&E prepared an estimate of the Direct Costs of the Project in the amount of \$20,046,155 based on the preliminary design. The Project Team considered the conditions known at the time to prepare the preliminary Direct Cost estimate. This estimate reflects the projected Labor, Material, and Services costs anticipated to be incurred to execute the Project.

SDG&E estimated Indirect Costs of the Project based on the estimated Direct Costs and other project related variables.

C. Actual Direct and Indirect Costs

Actual Direct Costs reflect the Labor, Material, and Services costs incurred to execute the Project. Actual Indirect Costs reflect costs for incremental overhead loaders in

Final Report for Supply Line 49-17 West Replacement Project

accordance with Company overhead allocation policies. The total loaded cost of the Project is \$37,512,409.

Table 4: Estimated and Actual Direct Costs and Variances⁶

Direct Costs (\$)	Estimate	Actuals	Delta Over/(Under)
Company Labor	543,469	843,071	299,602
Materials	2,055,021	598,942	(1,456,079)
Construction Contractor	11,068,545	13,757,702	2,689,157
Construction Management & Support	855,985	2,981,064	2,125,079
Environmental	601,872	682,663	80,791
Engineering & Design	2,102,539	7,175,579	5,073,040
Project Management & Services	718,678	1,094,893	376,215
ROW & Permits	429,533	1,039,608	610,075
GMA	1,670,513	1,991,449	320,936
Total Direct Costs	20,046,155	30,164,971	10,118,816

Table 5: Estimated and Actual Indirect Costs, Total Costs, and Variances⁷

Indirect Costs/Total Costs (\$)	Estimate	Actuals	Delta Over/(Under)
Overheads	1,998,182	3,407,984	1,409,802
AFUDC	2,006,359	3,465,964	1,459,605
Property Taxes	-	473,490	473,490
Total Indirect Costs	4,004,541	7,347,438	3,342,897
Total Direct Costs	20,046,155	30,164,971	10,118,816
Total Loaded Costs	24,050,696	37,512,409	13,461,713

D. Disallowance

For this replacement project, SDG&E identified 1700 feet of pipe as being installed after 1955 and lacking records that provide the minimum information necessary to demonstrate

⁶ Values may not add to total due to rounding.

⁷ Ibid.

Final Report for Supply Line 49-17 West Replacement Project

compliance with then-applicable industry standards or regulatory strength testing and recordkeeping requirements. Of the pipeline that was replaced, 1700 feet of Phase 1A pipe is disallowed. Therefore, a \$550,381 reduction to ratebase was calculated by multiplying 0.322 miles of pipe by \$1,709,257 per mile, which was SoCalGas and SDG&E's system average cost of pressure testing, at the time the pipeline was returned to service.

Final Report for Supply Line 49-17 West Replacement Project

V. CONCLUSION

SDG&E enhanced the safety of their integrated natural gas transmission system by prudently executing the 49-17 West Replacement Project. Through this Replacement Project, SDG&E successfully replaced 1.671 miles of pipeline in the City of San Diego. The total loaded cost of the Project is \$37,512,409.

SDG&E executed this project prudently through rerouting within city franchise to improve accessibility to the pipeline and to avoid environmentally sensitive areas. SDG&E adhered to all permit requirements for site restoration and completed work in accordance with permit requirements for traffic control, which minimized impacts to the community.

SDG&E engaged in prudent cost avoidance efforts by sharing laydown yards with other projects, minimized the use of [REDACTED] fittings in construction to avoid additional materials and welding costs, and utilizing bulk ordered pipe provided volume pricing for the [REDACTED] pipe.

End of Supply Line 49-17 West Replacement Project Final Report

Final Report for Supply Line 49-32-L Replacement Project

I. SUPPLY LINE 49-32-L REPLACEMENT PROJECT

A. Background and Summary

Supply Line 49-32-L is a predominantly [REDACTED] diameter transmission line that runs approximately 1.24 miles along Pacific Highway and the Ocean Beach Bike Path, beneath the Interstate 8 and Interstate 5 interchange in the City of San Diego, through a commercial area. The pipeline is primarily routed across a Class 3 location and traverses some Class 2 locations. This report describes the activities associated with Supply Line 49-32-L Replacement Project which consists of the replacement and reroute of 0.203 miles of pipeline in two sections along with the replacement of one mainline valve (MLV) and bridle assembly. The specific attributes of this Project are detailed in Table 1 below. The total loaded cost of the Project is \$8,297,294.

Final Report for Supply Line 49-32-L Replacement Project

Table 1: General Project Information

Project Name		Supply Line 49-32-L Section 1		
Project Type	Replacement			
Length	661 feet			
Location	San Diego			
Class	3			
MAOP (confidential)	[REDACTED]			
Pipe Vintage	1949			
Construction Start	08/22/2016			
Construction Finish	03/14/2017			
Original Pipe Diameter (confidential)	[REDACTED]			
New Diameter (confidential)	[REDACTED]			
Original SMYS ¹ (confidential)	[REDACTED]			
New SMYS (confidential)	[REDACTED]			
Project Name		Supply Line 49-32-L Section 2		
Project Type	Replacement			
Length	410 feet			
Location	San Diego			
Class	3			
MAOP (confidential)	[REDACTED]			
Pipe Vintage	1965			
Construction Start	04/25/2018			
Construction Finish	05/31/2018			
Original Pipe Diameter (confidential)	[REDACTED]			
New Diameter (confidential)	[REDACTED]			
Original SMYS ² (confidential)	[REDACTED]			
New SMYS (confidential)	[REDACTED]			
Project Costs (\$)	Capital	O&M	Total	
Loaded Project Costs	8,297,294	-	8,297,294	
Disallowed Costs	116,913	-	116,913	

¹ Highest percentage of Specified Minimum Yield Strength (SMYS) of Category 4 Criteria pipe.

² Pipeline attributes based on coupon results.

Final Report for Supply Line 49-32-L Replacement Project

B. Maps and Images

Figure 1: Satellite Image of Supply Line 49-32-L Replacement Project

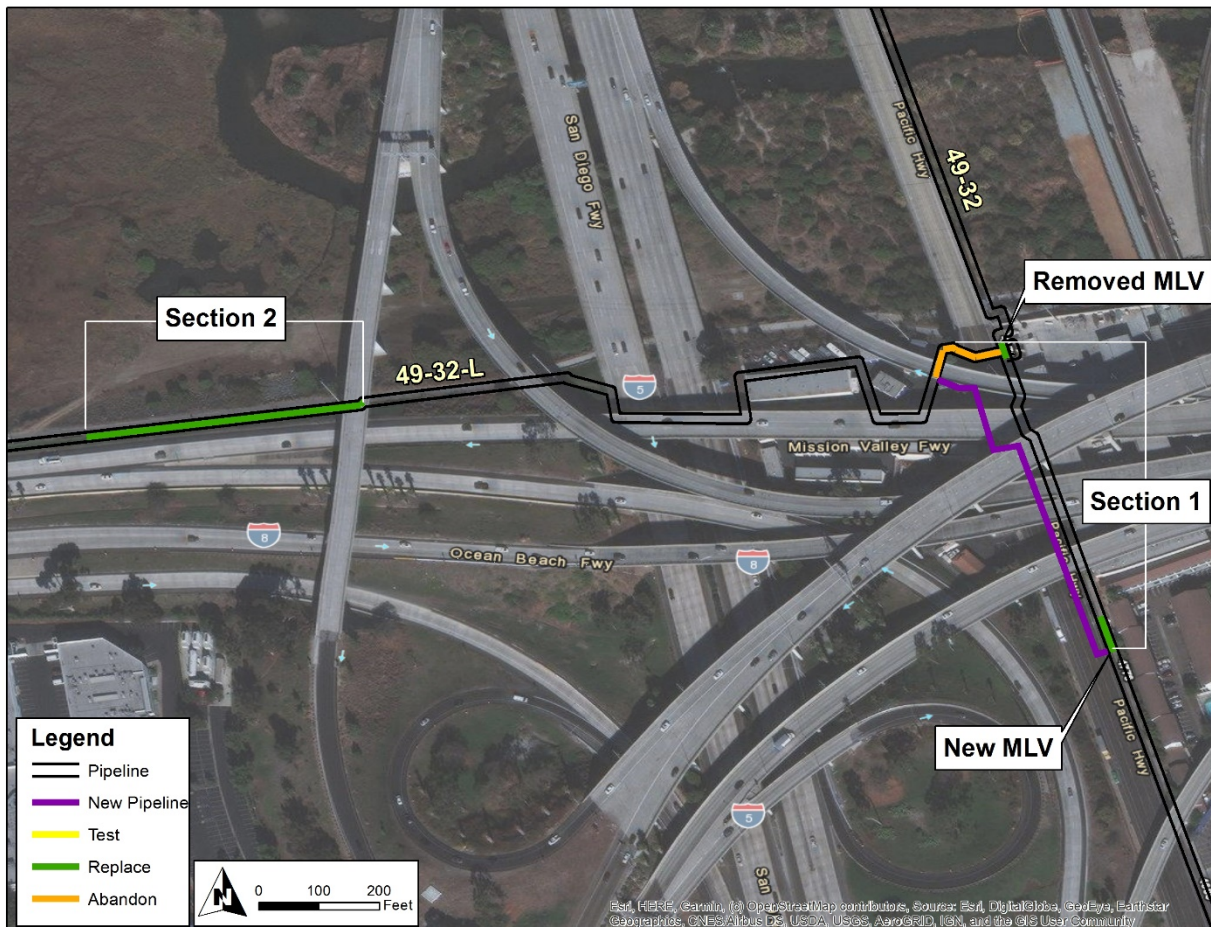

Final Report for Supply Line 49-32-L Replacement Project

Figure 2: Overview Map of Supply Line 49-32-L Replacement Project

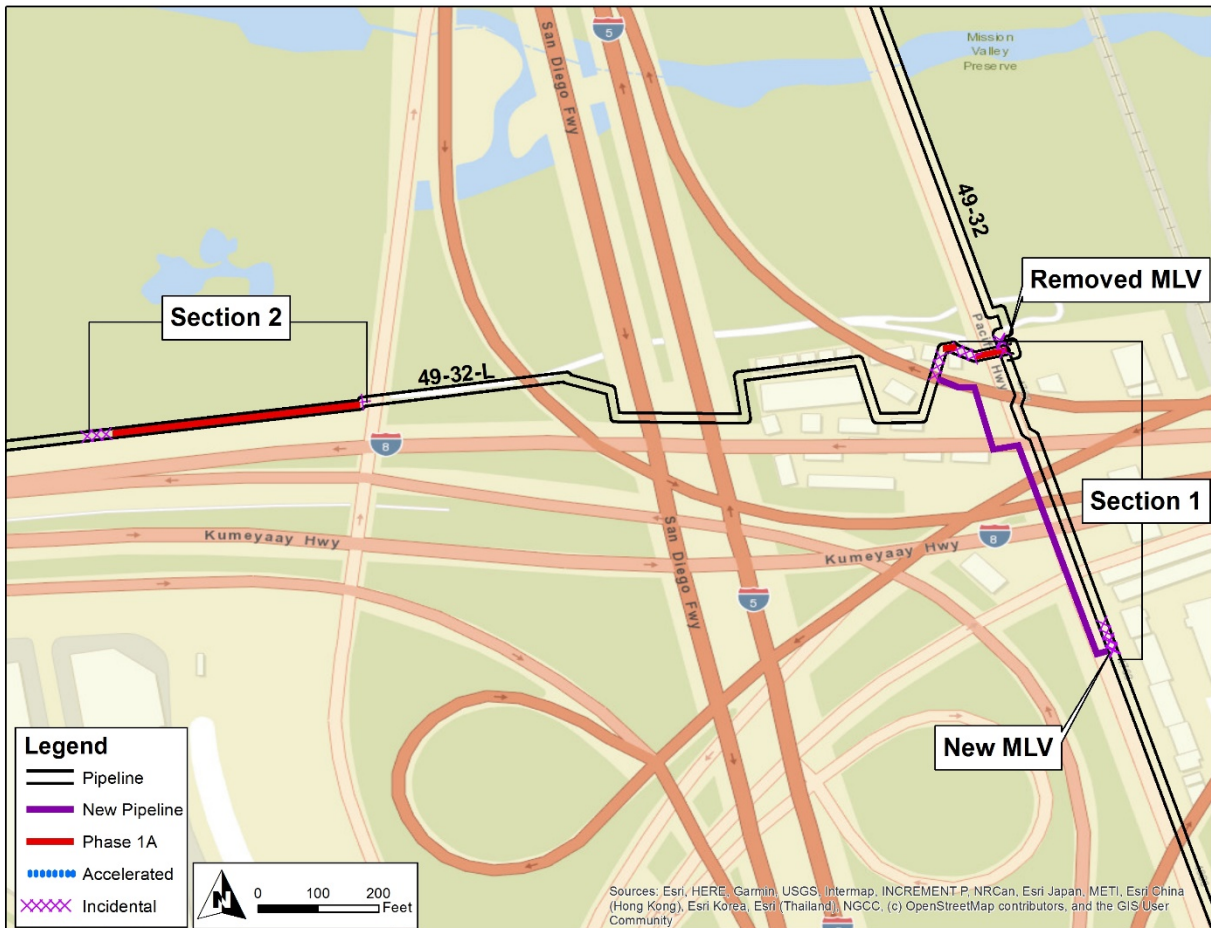

II. ENGINEERING, DESIGN, AND PLANNING

A. Project Scope

Table 2: Mileage Information

	Criteria	Accelerated	Incidental	New	Total ³
Section 1	0.028 mi.	0 mi.	0.057 mi.	0.040 mi.	0.125 mi.
	149 ft.	0 ft.	301 ft.	211 ft.	661 ft.
Section 2	0 mi.	0 mi.	0.075 mi.	0.003 mi.	0.078 mi.
	0 ft.	0 ft.	396 ft.	14 ft.	410 ft.
Final Mileage	0.028 mi.	0 mi.	0.132 mi.	0.043 mi.	0.203 mi.
	149 ft.	0 ft.	697 ft.	225 ft.	1,071 ft.

SoCalGas and SDG&E presented a conceptual project scope in workpapers supporting the 2011 PSEP filing.⁴ This progression of the project scope is summarized as follows:

1. 2011 PSEP Filing: SoCalGas and SDG&E did not identify Supply Line 49-32-L in the 2011 PSEP filing.
2. Scope Validation: Through scope validation activities, after the 2011 filing and before initiating execution of the Project, SDG&E identified 510 feet of Category 4 Criteria pipe.
3. Engineering, Design, and Constructability:
 - a. Section 1: The Project Team installed and rerouted 684 feet of [REDACTED] pipe and relocated one [REDACTED] MLV with bridle assembly. The tap from Supply Line 49-32-L tap Supply Line 49-32 and bridle were relocated south to accommodate the reroute.
 - b. Section 2: The Project Team installed 420 feet of [REDACTED] pipe along the Ocean Beach Bike Path.
 - c. The Project Team included Incidental mileage for constructability.

³ Values may not add to total due to rounding.

⁴ See Amended PSEP of SoCalGas and SDG&E, submitted December 2, 2011, in R.11-02-019 and subsequently transferred to A.11-11-002.

Final Report for Supply Line 49-32-L Replacement Project

4. **Final Project Scope:** The final project scope consists of 0.132 miles of insidental pipe, and the replacement and reroute of 879 feet of existing pipeline with 0.203 miles of new pipeline in two sections along with the replacement and relocation of one MLV and bridle assembly.

B. Decision Tree Analysis

SDG&E performed a PSEP Decision Tree analysis of Supply Line 49-32-L and confirmed the project design should commence as a Replacement Project.

Segments of less than 1,000 feet are identified for replacement under the approved PSEP Decision Tree because, for short segments of pipe, the logistical costs associated with pressure testing (for example, permitting, construction, water handling, and service disruptions for a non-looped system) can approach or exceed the cost of replacement. In such circumstances, replacement affords a more cost-effective approach to achieving compliance with D.11-06-017 while providing equal safety enhancement benefits. Moreover, installation of the new segment can usually be performed while the existing service is maintained to customers, thereby avoiding service disruptions that may otherwise occur during pressure testing.

Through this Decision Tree analysis, SDG&E identified replacement as the more prudent option. Key considerations that support SDG&E's determination to replace this segment include:

1. **Shut-In Analysis:** The Project Team completed a Request for Engineering Review (RER) analysis and concluded the line could be shut in with the use of stopple fittings or temporary bypass.
2. **Customer Impacts:** The Project Team determined that there are no taps at the replacement site but there are two taps feeding regulator stations downstream of the worksite for approximately 19,000 customers to Ocean Beach and Point Loma. The Project Team used stopple fittings as opposed to the installation of a temporary

Final Report for Supply Line 49-32-L Replacement Project

bypass at the north tie-in location of Section 1. The Project Team also used stopple fittings for the tie-in of Section 2 along the Ocean Beach Bike Path.

3. Permit Conditions: Caltrans and City of San Diego required permits for traffic control and encroachment.
4. Piggability: Non-piggable.
5. Pipe Vintage:
 - a. Section 1: 1949.
 - b. Section 2: 1965.
6. Existing Pipe Attributes: Back to back elbows on the existing pipeline rendering the pipeline non-piggable.
7. Longseam Type: Unknown.
8. Longseam Repair History: No identified issues.
9. Condition of Coating: No identified issues.
10. History of Leaks: No identified issues.

C. Engineering, Design, and Planning Factors

SDG&E reviewed pipeline drawings and other information, contacted internal planning groups, communicated with external stakeholders, conducted survey activities, including reviewing public records and potholing of the area to confirm the presence of underground utilities and substructures, and completed a pre-design site walk. Key factors that influenced the engineering and design of the Project are as follows:

1. Shut-In Analysis: As discussed above, the Project Team completed an RER analysis and concluded the line could be shut in with the use of stopple fittings or temporary bypass.
2. Customer Impact: Per the RER, the Project Team identified that there are no taps at the replacement site but there are two taps feeding regulator stations downstream of the worksite for approximately 19,000 customers to Ocean Beach and Point Loma.

Final Report for Supply Line 49-32-L Replacement Project

As discussed above, the Project utilized stopple fittings for Section 1 and Section 2 to prevent customer impacts.

3. Community Impact:
 - a. Section 1: The Project Team routed a portion of the new pipeline and a new valve to a location that minimized the impact to a local motel.
 - b. Section 2: The Project Team collaborated with local San Diego Bike Associations, Caltrans, and the City of San Diego to determine the preferred means of mitigating community impact and ultimately chose to use non-slip metal plates and provided a detour route for the bike lanes.
4. Schedule Coordination: The Project Team coordinated with an adjacent Navy fuel pipeline project to avoid conflicts with Caltrans traffic control plans as construction activities for both are within the same vicinity.
5. Known Substructures: Potholing activities were performed and confirmed known substructures.
6. Reroute: The northern alignment of Section 1 was rerouted to maintain separation from the new Navy fuel pipeline.
7. Permit Conditions: Caltrans and City of San Diego permits were required for traffic control and encroachment. The Project Team negotiated with the City of San Diego to allow for extended hours Monday through Friday, from 7AM to 7PM.
8. Land Use: The Project Team stored the materials for Section 2 on SDG&E owned property.
9. Environmental: The Project Team obtained and implemented a Storm Water Pollution Prevention Plan (SWPPP) and planned and implemented typical abatement activities.
10. Valves: The Project Team replaced an existing MLV on Section 1.
11. Coupons: The Project Team completed coupon sampling of the existing Section 2 pipeline to validate the Criteria pipeline scope.

Final Report for Supply Line 49-32-L Replacement Project

D. Scope Changes

Through engineering, design, and planning activities, SDG&E determined that changes in scope were appropriate to enhance the design of the Project and address engineering factors. As a result, the preliminary cost estimate does not fully reflect the final scope. The notable change was a revision of the design to utilize a single stopple fitting as opposed to the installation of a temporary bypass with two stopple fittings at the north tie-in location of Section 1.

Final Report for Supply Line 49-32-L Replacement Project

III. CONSTRUCTION

A. Construction Contractor Selection

The Project Team prepared an initial cost estimate based on the preliminary design. Following completion of the engineering, design, and planning activities described above, the Project Team directed the Performance Partner to prepare cost estimates based on a more detailed engineering design package, which included the updated design described in the discussion of notable Scope Changes above. SDG&E awarded the construction contract to the Performance Partner.

1. SDG&E’s Preliminary Construction Cost Estimate (confidential): SDG&E’s preliminary cost estimate for construction was [REDACTED].
2. Construction Contractor’s Target Price Estimate (confidential): The Construction Contractor’s cost estimate was [REDACTED], which was [REDACTED] than SDG&E’s preliminary cost estimate for construction.

B. Construction Schedule

Table 3: Construction Timeline

Section 1

Construction Start Date	08/22/2016
Construction Completion Date	03/14/2017
NOP Date	11/07/2016

Section 2

Construction Start Date	04/25/2018
Construction Completion Date	05/31/2018
NOP Date	05/17/2018

Final Report for Supply Line 49-32-L Replacement Project

C. Changes During Construction

SDG&E successfully mitigated conditions during construction in a manner that minimized potential impacts on project scope, cost, and schedule. As a result, these conditions did not result in any notable change orders.

Final Report for Supply Line 49-32-L Replacement Project

Figure 4: Shoring Jacks



Final Report for Supply Line 49-32-L Replacement Project

Figure 5: Bell Hole Paving



Final Report for Supply Line 49-32-L Replacement Project

D. Commissioning and Site Restoration

Commissioning activities include restoration of the site, final inspection and placement of the pipeline back into service, transportation and disposal of hydrotest water and hazardous material, and site demobilization. Closeout activities include development of final drawings, finalization of a reconciliation package, and updates to company recordkeeping systems to reflect the completed scope of work.

IV. PROJECT COSTS

A. Cost Avoidance Actions

SDG&E exercised due diligence in the planning, design, and construction activities for this project to minimize or avoid costs when prudent to do so. As discussed above, the Project Team conducted a site visit to identify and incorporate discernible site conditions into the engineering, design, and planning of the Project. Specific examples of cost avoidance actions taken on this project are:

1. Materials: Bulk ordered pipe provided volume pricing for the [REDACTED] pipe.
2. Schedule Coordination: For Section 1, the Project Team coordinated with the stopple fitting contractor to bundle multiple projects within the region to reduce the mobilization and demobilization costs.
3. Water Management: The Project Team used recycled water from the South Bay Water Reclamation Plant.
4. Permit Conditions: Successful negotiations with the City of San Diego resulted in extended hours beyond what is normally approved. Construction was approved to work Monday through Friday, from 7AM to 7PM.

B. Cost Estimate

Based on the preliminary design, once the project scope was confirmed and engineering, design, and planning activities were underway, SDG&E prepared an estimate of the Direct Costs of the Project in the amount of \$6,865,618. The Project Team considered the conditions known at the time to prepare the preliminary Direct Cost estimate. This estimate reflects the projected Labor, Material, and Services costs anticipated to be incurred to execute the Project.

SDG&E estimated Indirect Costs of the Project based on the estimated Direct Costs and other project related variables.

Final Report for Supply Line 49-32-L Replacement Project

C. Actual Direct and Indirect Costs

Actual Direct Costs reflect the Labor, Material, and Services costs incurred to execute the Project. Actual Indirect Costs reflect costs for incremental overhead loaders in accordance with Company overhead allocation policies. The total loaded cost of the Project is \$8,297,294.

Table 4: Estimated and Actual Direct Costs and Variances⁵

Direct Costs (\$)	Estimate	Actuals	Delta Over/(Under)
Company Labor	396,542	262,253	(134,289)
Materials	307,234	270,743	(36,491)
Construction Contractor	3,572,448	2,713,908	(858,540)
Construction Management & Support	256,780	755,334	498,554
Environmental	339,460	182,326	(157,134)
Engineering & Design	924,370	2,074,661	1,150,291
Project Management & Services	403,029	339,082	(63,947)
ROW & Permits	93,620	99,701	6,081
GMA	572,135	380,852	(191,283)
Total Direct Costs	6,865,618	7,078,861	213,242

Table 5: Estimated and Actual Indirect Costs, Total Costs, and Variances⁶

Indirect Costs/Total Costs (\$)	Estimate	Actuals	Delta Over/(Under)
Overheads	962,109	775,573	(186,536)
AFUDC	772,891	390,404	(382,487)
Property Taxes	-	52,456	52,456
Total Indirect Costs	1,735,000	1,218,433	(516,567)
Total Direct Costs	6,865,618	7,078,861	213,242
Total Loaded Costs	8,600,618	8,297,294	(303,324)

⁵ Values may not add to total due to rounding.

⁶ Ibid

Final Report for Supply Line 49-32-L Replacement Project

D. Disallowance

For this replacement project, SoCalGas identified 361 feet of pipe as being installed after 1955, and lacking records that provide the minimum information necessary to demonstrate compliance with then-applicable industry standards or regulatory strength testing and recordkeeping requirements. Of the pipeline that was replaced, 361 feet of Phase 1A pipe is disallowed. Therefore, a \$116,913 reduction to ratebase was calculated by multiplying 0.0684 miles of pipe by \$1,709,257 per mile, which was SoCalGas and SDG&E's system average cost of pressure testing at the time the pipeline was returned to service.

Final Report for Supply Line 49-32-L Replacement Project

V. CONCLUSION

SDG&E enhanced the safety of their integrated natural gas transmission system by prudently executing the Supply Line 49-32-L Replacement Projects. Through this Replacement Project, SDG&E successfully replaced 0.203 miles of pipeline and one MLV in the City of San Diego. The total loaded cost of the Project is \$8,297,294.

SDG&E executed this project prudently through coordination with vendors for efficient use of resources and equipment to maintain service to customers. The Project Team coordinated with an adjacent Navy fuel pipeline project to avoid conflicts with Caltrans traffic control plans as construction activities for both are within the same vicinity.

SDG&E engaged in prudent cost avoidance efforts by negotiating favorable working hours with the city, maintaining customer service with the use of stopple fittings, and utilizing bulk ordered pipe that provided volume pricing for the [REDACTED] pipe.

End of Supply Line 49-32-L Replacement Project Final Report

I. LA MESA GATE STATION REPLACEMENT PROJECT

A. Background and Summary

The La Mesa Gate Station is a regulator station that serves as the junction interconnecting Supply Line 49-16 and Supply Line 49-17. It is located in the City of La Mesa in a Class 3 location. This report describes the activities associated with the La Mesa Gate Station Replacement Project which consists of the installation and reroute of 313 feet of pipeline and the installation of one mainline valve (MLV). Subsequently, the scope of this Project was expanded to include the abandonment of the section of Supply Line 49-15 between Highway 125 and La Mesa Gate Station (Section 1), removal of a reg station, and site restoration activity associated with the Supply Line 49-15 Replacement Project¹. The final abandonment of Section 1 could not be executed until the La Mesa Gate Station Replacement Project was tied-in. The specific attributes of this Project are detailed in Table 1 below. The total loaded cost of the Project is \$5,560,106.

¹ Supply Line 49-15 Replacement Project was filed for reasonableness review in A.18-11-010.

Final Report for La Mesa Gate Station Replacement Project

Table 1: General Project Information

Project Name		La Mesa Gate Station Replacement		
Project Type	Replacement			
Length	313 feet			
Location	La Mesa			
Class	3			
MAOP (<i>confidential</i>)	[REDACTED]			
Pipe Vintage	1955			
Construction Start	11/13/2018			
Construction Finish	06/07/2019			
Original Pipe Diameter (<i>confidential</i>)	[REDACTED]			
New Diameter (<i>confidential</i>)	[REDACTED]			
Original SMYS ¹ (<i>confidential</i>)	[REDACTED]			
New SMYS (<i>confidential</i>)	[REDACTED]			
Project Name		Supply Line 49-15 Section 1 Abandonment		
Project Type	Abandonment			
Length	1.676 miles			
Location	La Mesa			
Class	3			
MAOP (<i>confidential</i>)	[REDACTED]			
Pipe Vintage	1950			
Construction Start	11/13/2018			
Construction Finish	06/07/2019			
Original Pipe Diameter (<i>confidential</i>)	[REDACTED]			
New Diameter (<i>confidential</i>)	N/A			
Original SMYS ¹ (<i>confidential</i>)	[REDACTED]			
New SMYS (<i>confidential</i>)	N/A			
Project Costs (\$)		Capital	O&M	Total
Loaded Project Costs		5,560,106	-	5,560,106
Disallowed Costs		-	-	-

Final Report for La Mesa Gate Station Replacement Project

B. Maps and Images

Figure 1: Satellite Image of La Mesa Gate Station Replacement Project

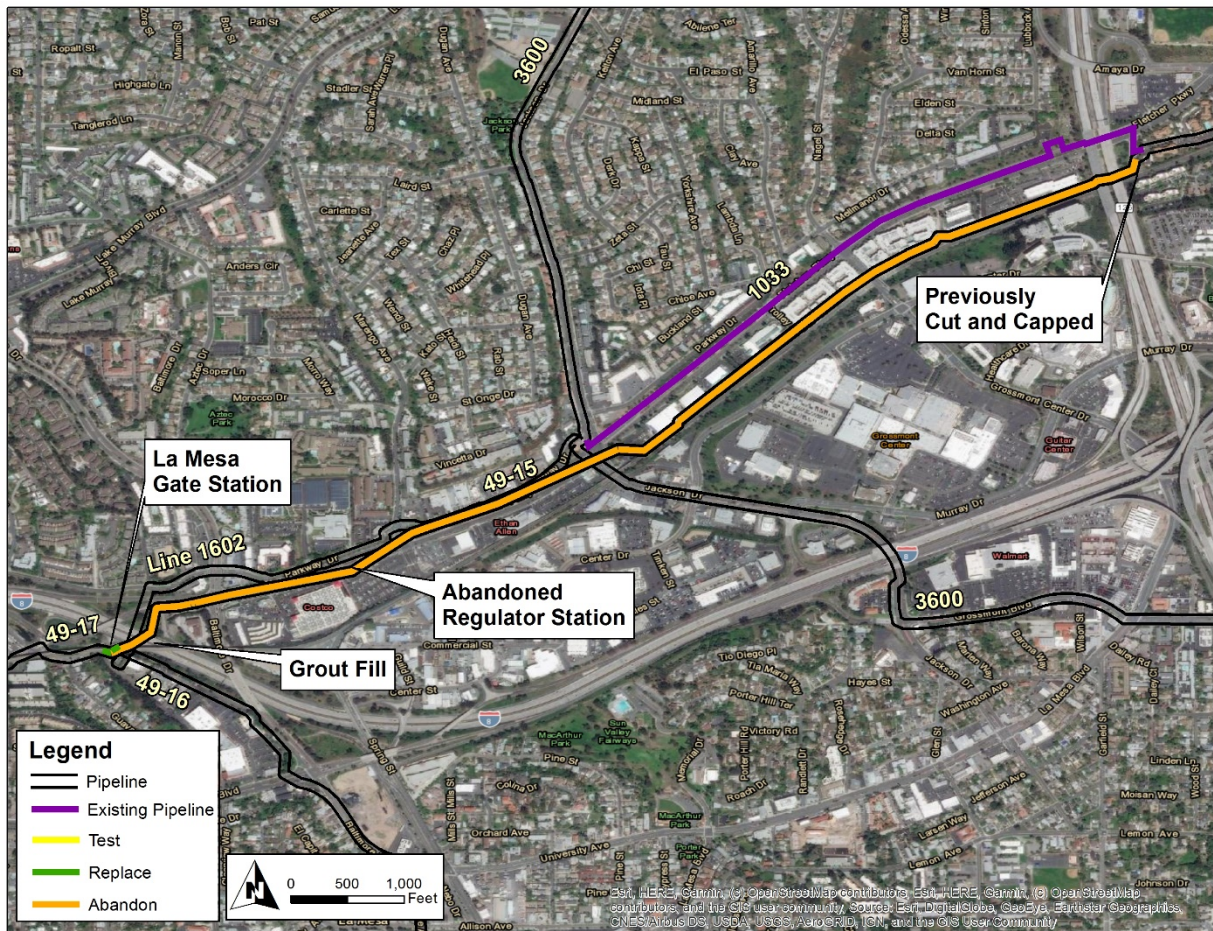

Final Report for La Mesa Gate Station Replacement Project

Figure 2: Overview Map of La Mesa Gate Station Replacement Project

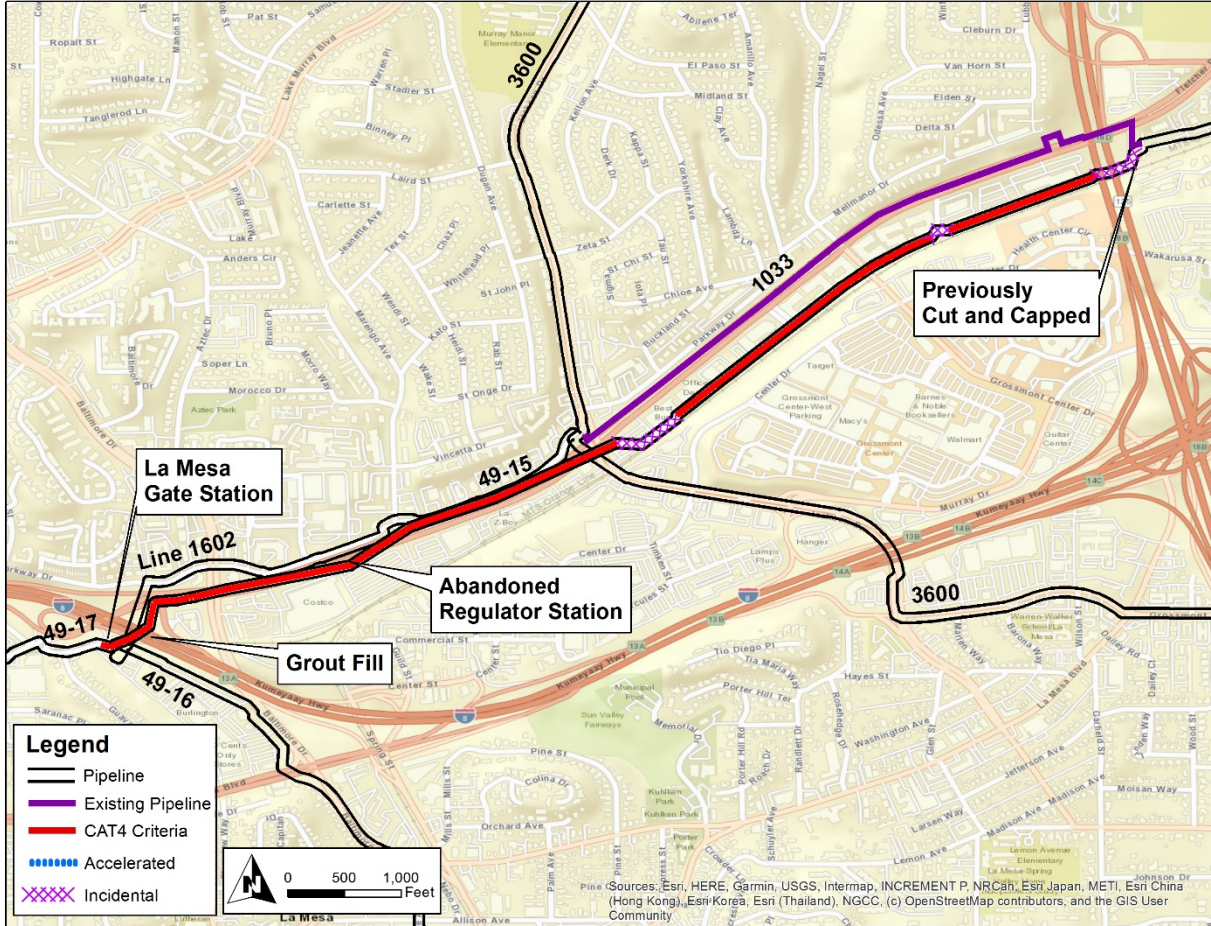

Final Report for La Mesa Gate Station Replacement Project

Figure 3: Satellite Image/Schematic of La Mesa Gate Station

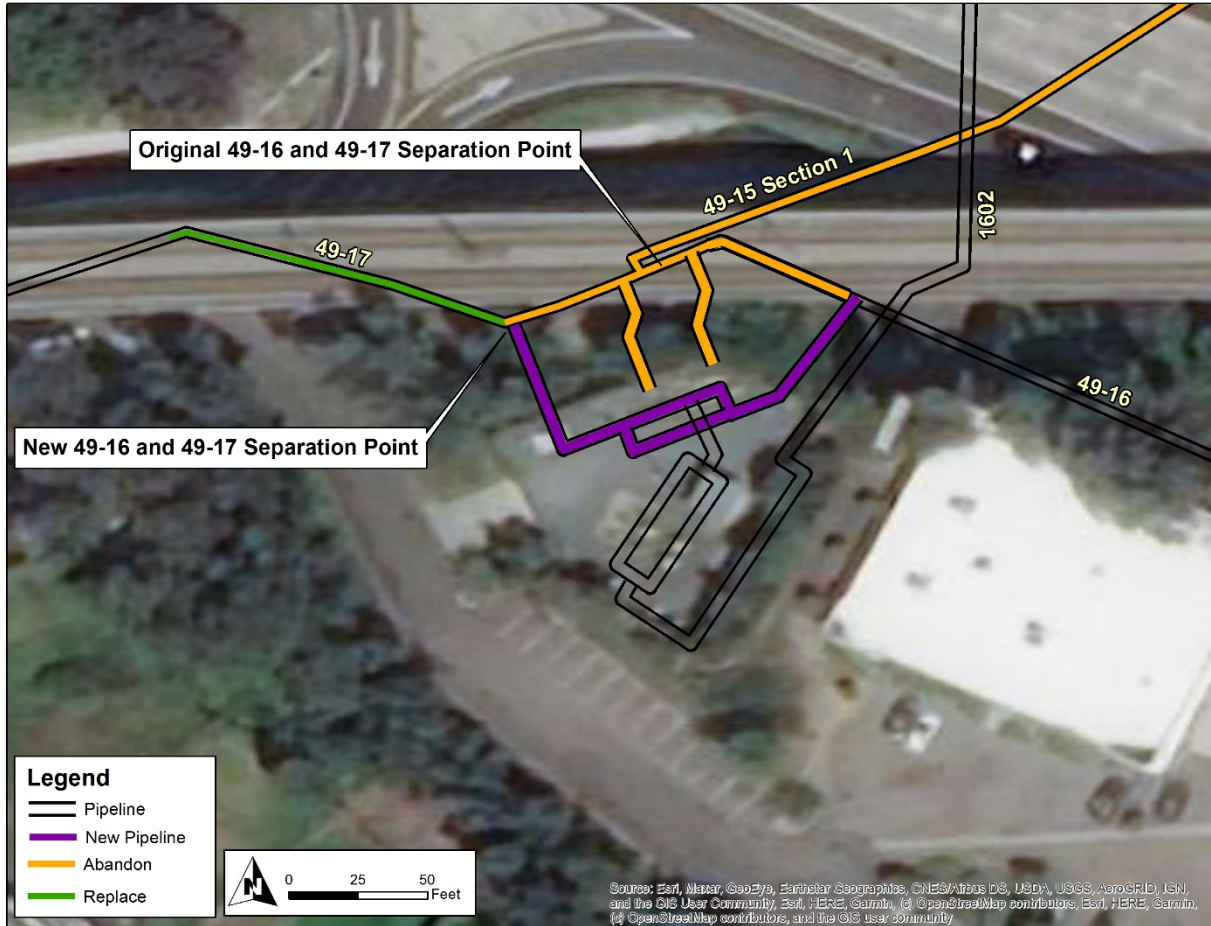

Final Report for La Mesa Gate Station Replacement Project

Figure 4: Overview Map/Schematic of La Mesa Gate Station

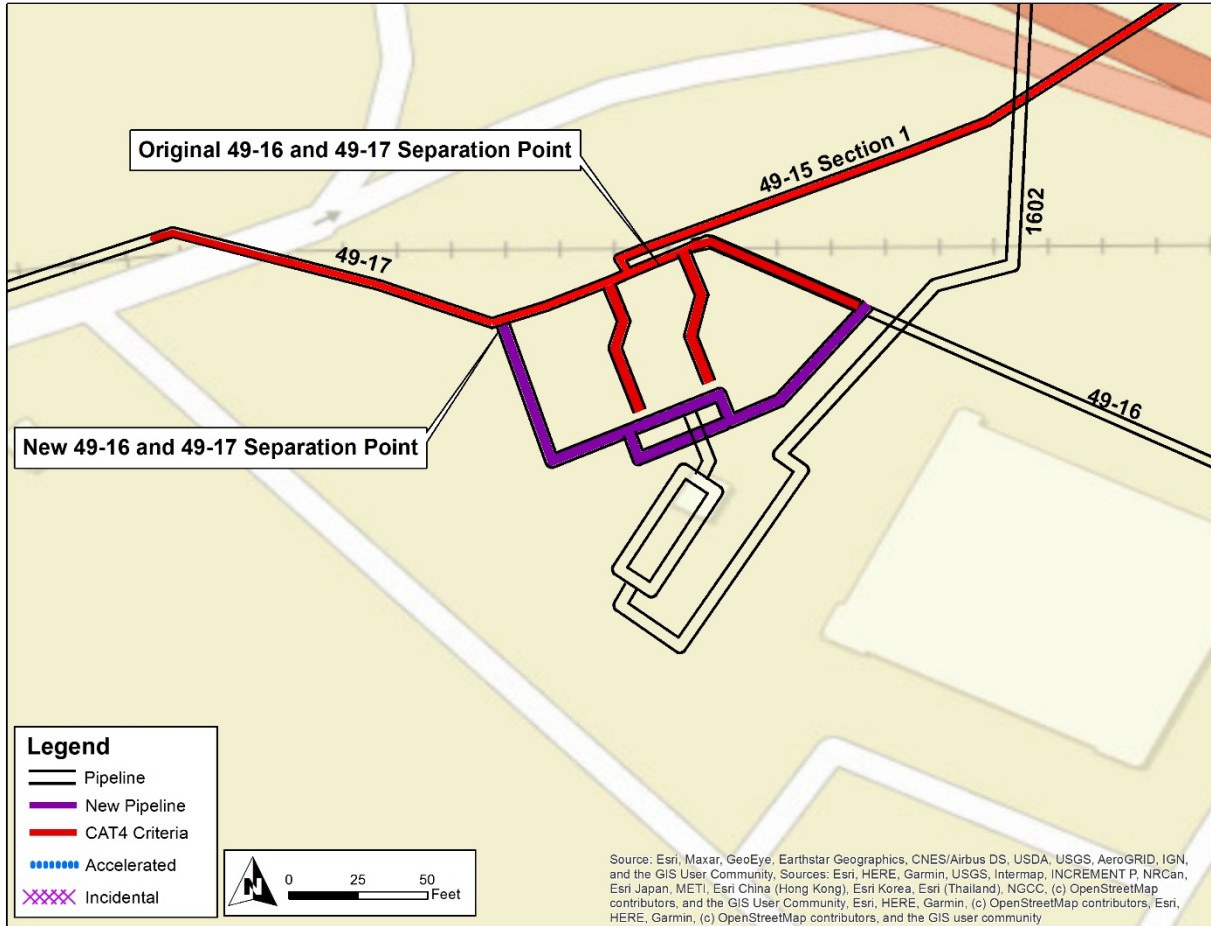

II. ENGINEERING, DESIGN, AND PLANNING

A. Project Scope

Table 2: Mileage Information

	Criteria	Accelerated	Incidental	New	Total ²
La Mesa Gate Station	0.028 mi.	0 mi.	0.031 mi.	0 mi.	0.059 mi.
	150 ft.	0 ft.	161 ft.	2 ft.	313 ft.
49-15 Section 1 Abandonment	1.461 mi.	0 mi.	0.215 mi.	0 mi.	1.676 mi.
	7,714 ft.	0 ft.	1,135 ft.	0 ft.	8,849 ft.

SoCalGas and SDG&E presented a conceptual project scope in workpapers supporting the 2011 PSEP filing.³ Prior to initiating execution of the Project in 2018, SDG&E reviewed existing pipeline records to validate the scope of the Project. During the Engineering, Design, and Planning phase, SDG&E further refined the scope. This progression of the project scope is summarized as follows:

1. 2011 PSEP Filing:

- a. SoCalGas and SDG&E identified Supply Line 49-16 as a Phase 1A Replacement Project comprised of 0.722 miles of Category 4 Criteria pipe and 8.868 miles of Accelerated pipe.⁴
- b. SoCalGas and SDG&E identified Supply Line 49-17 as a Phase 1A Replacement Project comprised of 5.259 miles of Category 4 Criteria pipe and 0.553 miles of Accelerated pipe.⁵

² Values may not add to total due to rounding.

³ See Amended PSEP of SoCalGas and SDG&E, submitted December 2, 2011, in R.11-02-019 and subsequently transferred to A.11-11-002.

⁴ Supply Line 49-16 Replacement and Hydrotest Projects workpapers are being submitted for reasonableness review in this filing.

⁵ Supply Line 49-17 East Replacement Project and Supply Line 49-17 West Replacement Project workpapers are being submitted for reasonableness review in this filing.

Final Report for La Mesa Gate Station Replacement Project

- c. SoCalGas and SDG&E identified Supply Line 49-15 as a Phase 1A Replacement and Hydrotest Project comprised of 1.978 miles of Category 4 Criteria pipe and 4.932 miles of Accelerated pipe.
2. Scope Validation: Through scope validation activities, after the 2011 filing and before initiating execution of these Projects, SDG&E:
 - a. Increased the scope of the Supply Line 49-16 Project by 132 feet of Category 4 Criteria Pipe and identified 30 feet of Category 4 Criteria Pipe was within or adjacent to the La Mesa Gate Station.
 - b. Increased the scope of the Supply Line 49-17 Project by 0.443 miles of Category 4 Criteria pipe and identified 120 feet of Category 4 Criteria Pipe was within or adjacent to the La Mesa Gate Station.
 - c. Increased the scope of the Supply Line 49-15 Project by 1.056 miles of Category 4 Criteria pipe.
3. Engineering, Design, and Constructability:
 - a. The Project Team determined that due to the unique design aspects of the interconnection at the La Mesa Station of Supply Line 49-16 and Supply Line 49-17, replacement of these pipeline segments should be executed jointly as a separate project rather than be included in Supply Line 49-16 Replacement Project and Supply Line 49-17 Replacement Project, respectively. The Project Team determined that the most efficient design option was to relocate the interconnection point between Supply Line 49-16 and Supply Line 49-17, and reroute Supply Line 49-16 within the existing station.
 - b. After the preliminary estimate was prepared, the Project Team determined that completion of the final abandonment activities of Supply Line 49-15 Section 1 between Highway 125 and La Mesa Gate Station could only occur after the completion of the La Mesa Gate Station Replacement Project in order to maintain uninterrupted service to a regulator station and should be added to the scope of this project. Final abandonment activities included abandonment of the regulator

Final Report for La Mesa Gate Station Replacement Project

station and grout filling of existing pipeline crossing Caltrans right of way (ROW) across Interstate 8.

4. Final Project Scope: The final project scope consists of the replacement of 313 feet of pipeline to interconnect Supply Line 49-16 and Supply Line 49-17 into the Mesa Gate Station, 0.246 miles of incidental pipe, and final abandonment of 1.676 miles of Supply Line 49-15 Section 1.

B. Decision Tree Analysis

La Mesa Gate Station:

SDG&E performed a PSEP Decision Tree analysis of Supply Lines 49-16 and Supply Line 49-17 and confirmed the project design should commence as a Replacement.

Segments of less than 1,000 feet are identified for replacement under the approved PSEP Decision Tree because, for short segments of pipe, the logistical costs associated with pressure testing (for example, permitting, construction, water handling, and service disruptions for a non-looped system) can approach or exceed the cost of replacement. In such circumstances, replacement affords a more cost-effective approach to achieving compliance with D.11-06-017 while providing equal safety enhancement benefits. Moreover, installation of the new segment can usually be performed while the existing service is maintained to customers, thereby avoiding service disruptions that may otherwise occur during pressure testing.

1. Shut-In Analysis: The Project Team completed a Request for Engineering Review (RER) analysis and concluded that connected regulator stations cannot be shut-in during winter conditions. The Project Team also concluded that Supply Line 49-17 and La Mesa Gate Station could be disconnected temporarily with minimal system impact.
2. Customer Impacts: Per the RER, the Project Team identified that 18,600 customers are fed by connected regulator stations. Bridled feed can maintain customer service within the shut-in limits.

Final Report for La Mesa Gate Station Replacement Project

3. Piggability: Non-piggable.
4. Pipe Vintage: 1951.
5. Existing Pipe Attributes: The Project Team identified existing non-piggable features along the existing pipeline.
6. Longseam Type: Unknown.
7. Longseam Repair History: No identified issues.
8. Condition of Coating: No identified issues.
9. History of Leaks: No identified issues.

Supply Line 49-15 Section 1 Abandonment:

SDG&E performed a PSEP Decision Tree analysis of Supply Line 49-15 and confirmed the project design should commence as a Replacement Project.⁶ The final abandonment activities were not subject to a decision tree analysis.

C. Engineering, Design, and Planning Factors

SDG&E reviewed pipeline drawings and other information, contacted internal planning groups, communicated with external stakeholders, conducted survey activities, including reviewing public records and potholing of the area to confirm the presence of underground utilities and substructures, and completed a pre-design site walk. Key factors that influenced the engineering, design, and the preparation of the preliminary cost estimate of the Project are as follows:

La Mesa Gate Station Replacement:

1. Shut-In Analysis: As discussed above, the Project Team completed an RER analysis and concluded that the line could be shut-in by using a valve bridle to maintain service to this regulator station, however shut-in could not occur during winter conditions.

⁶ The Decision Tree Analysis performed for Supply Line 49-15 Replacement Project was submitted in A.18-11-010 workpapers.

Final Report for La Mesa Gate Station Replacement Project

2. Customer Impact: Per the RER, the Project Team identified that 18,600 customers are fed by connected regulator stations. Bridled feed can maintain customer service within the shut-in limits.
3. Community Impact: Traffic control was necessary and occasional noise impacted the project site.
4. Constructability: Workspace at the site was constrained due to the existing gas pressure regulator station, a sloped bank and other infrastructure surrounding the work location. Furthermore, an elevated electrified light rail track crosses above the work location limiting the use of cranes and tall equipment. The available work area was relatively small with the perimeter closely bound by a water drainage channel, Interstate 8 and related freeway on ramps and city surface streets. Other than existing gas pipelines and the aforementioned constraints, tThe Project Team did not identify any existing substructures that affected the design and engineering at this site.
5. Permit Conditions:
 - a. The City of La Mesa required an encroachment and Traffic Control Plan (TCP) for work outside of La Mesa Gate Station and Fletcher Parkway.
 - b. Caltrans required an encroachment and TCP for work outside of La Mesa Gate Station and Fletcher Parkway.
6. Land Use: No identified issues.
7. Environmental:
 - a. A water discharge permit was required from the City of San Diego to transport hydrotest water to a nearby water treatment facility.
 - b. The Project Team planned for asbestos abatement of all pipe being removed.
8. Valves: One existing MLV was replaced.

D. Scope Changes

Through engineering, design, and planning activities, SDG&E determined that changes in scope were appropriate to enhance the design of the Project and address engineering factors. As a result, the preliminary cost estimate does not fully reflect the final scope.

Final Report for La Mesa Gate Station Replacement Project

The Project Team included the remaining abandonment activities of Supply Line 49-15 Section 1 with this Project to avoid the cost of a separate mobilization. The final abandonment activities of Supply Line 49-15 Section 1 could not occur until the La Mesa Gate Station Replacement Project was tied-in and Caltrans permits were received.

Supply Line 49-15 Section 1 Abandonment:

As part of the Supply Line 49-15 Replacement Project, SDG&E reviewed pipeline drawings and other information, contacted internal planning groups, communicated with external stakeholders, conducted survey activities including reviewing public records and potholing of the area to confirm the presence of underground utilities and substructures, and completed a pre-design site walk. Subsequently, the Project Team determined that the post completion abandonment of the Project needed to be postponed to maintain uninterrupted service to a regulator station and due to delays in receiving Caltrans permits. This was determined after creation of the preliminary cost estimate for the La Mesa Gate Station Replacement Project and is not included in the initial project scope. Key factors that influenced the engineering and design of the Abandonment Project are as follows:

1. Permit Conditions:
 - a. Encroachment and traffic control permits were required from the City of La Mesa and Caltrans.
 - b. The Project Team received Caltrans feedback that necessitated multiple revisions of project plans, requiring additional engineering and design time. This resulted in protracted and unexpected delays.
3. Shut-In Analysis: The Project Team completed an RER analysis and concluded that the existing customers could maintain uninterrupted service through backfeeding from adjacent regulator stations following the completion of the abandonment of Supply Line 49-15.
4. Customer Impact: The Project Team did not identify service disruptions to customers.
5. Community Impact: The Project Team utilized traffic control at the construction sites.

Final Report for La Mesa Gate Station Replacement Project

6. Known Substructures: The Project Team performed potholing of the area and identified multiple substructures.
7. Land Use: The Project Team utilized SDG&E property for the laydown yard.
8. Environmental:
 - a. The Project Team identified preserved vegetation located near the pipeline route.
 - b. Asbestos Containing Material (ACM) was identified at the preexisting automation equipment shelter which required abatement.
 - c. The Project Team obtained a Wastewater Permit to filter and discharge water to the sewer.

III. CONSTRUCTION

A. Construction Contractor Selection

The Project Team prepared an initial cost estimate based on the preliminary design. Following completion of the engineering, design, and planning activities described above, the Project Team directed the Performance Partner to prepare cost estimates based on a more detailed engineering design package, which included the abandonment of Supply Line 49-15 Section 1 as described in the Scope Change section above. SDG&E awarded the construction contract to the Performance Partner.

1. SDG&E’s Preliminary Construction Cost Estimate (confidential): SDG&E’s preliminary cost estimate for construction was [REDACTED]
2. Construction Contractor’s Target Price Estimate (confidential): The Construction Contractor’s cost estimate was [REDACTED] which was [REDACTED] than SDG&E’s preliminary cost estimate for construction.

B. Construction Schedule

Table 3: Construction Timeline

Construction Start	11/13/2018
Construction Completion	06/07/2019
NOP Date	03/06/2019

C. Changes During Construction

SDG&E successfully mitigated conditions during construction in a manner that minimized potential impacts on project scope, cost, and schedule. As a result, these conditions did not result in any notable change orders.

Final Report for La Mesa Gate Station Replacement Project

Figure 5: New Above Grade MLV



Final Report for La Mesa Gate Station Replacement Project

D. Commissioning and Site Restoration

Commissioning activities include restoration of the site, final inspection and placement of the pipeline back into service, transportation and disposal of hydrotest water and hazardous material, and site demobilization. Closeout activities include development of final drawings, finalization of a reconciliation package, and updates to company recordkeeping systems to reflect the completed scope of work.

IV. PROJECT COSTS

A. Cost Avoidance Actions

SDG&E exercised due diligence in the planning, design, and construction activities for this project to minimize or avoid costs when prudent to do so. As discussed above, the Project Team conducted a site visit to identify and incorporate discernible site conditions into the engineering, design, and planning of the Project. Specific examples of cost avoidance actions taken on this project are:

1. Materials: Bulk ordered pipe provided volume pricing for the [REDACTED] pipe.
2. Schedule Coordination: The Project Team coordinated the final abandonment activities of Supply Line 49-15 Section 1 with the La Mesa Gate Station Replacement Project to utilize a single mobilization, blowdown, and purging.

B. Cost Estimate

Based on the preliminary design, once the project scope was confirmed and engineering, design, and planning activities were underway, SDG&E prepared an estimate of the Direct Costs of the Project in the amount of \$7,069,433. The Project Team considered the conditions known at the time to prepare the preliminary Direct Cost estimate. This estimate reflects the projected Labor, Material, and Services costs anticipated to be incurred to execute the Project.

SDG&E estimated Indirect Costs of the Project based on the estimated Direct Costs and other project related variables.

C. Actual Direct and Indirect Costs

Actual Direct Costs reflect the Labor, Material, and Services costs incurred to execute the Project. Actual Indirect Costs reflect costs for incremental overhead loaders in

Final Report for La Mesa Gate Station Replacement Project

accordance with Company overhead allocation policies. The total loaded cost of the Project is \$5,560,106.

Table 4: Estimated and Actual Direct Costs and Variances⁷

Direct Costs (\$)	Estimate	Actuals ⁸	Delta Over/(Under)
Company Labor	441,177	206,613	(234,564)
Materials	434,033	96,571	(337,462)
Construction Contractor	4,167,658	2,100,691	(2,066,967)
Construction Management & Support	368,577	474,105	105,528
Environmental	130,925	101,451	(29,474)
Engineering & Design	463,779	1,156,274	692,495
Project Management & Services	248,393	279,818	31,425
ROW & Permits	225,772	41,476	(184,296)
GMA	589,119	173,219	(415,900)
Total Direct Costs	7,069,433	4,630,217	(2,439,216)

Table 5: Estimated and Actual Indirect Costs, Total Costs, and Variances⁹

Indirect Costs/Total Costs (\$)	Estimate	Actuals	Delta Over/(Under)
Overheads	1,099,554	568,732	(530,822)
AFUDC	565,995	301,612	(264,383)
Property Taxes	0	59,545	59,545
Total Indirect Costs	1,665,549	929,889	(735,660)
Total Direct Costs	7,069,433	4,630,217	(2,439,216)
Total Loaded Costs	8,734,982	5,560,106	(3,174,876)

⁷ Values may not add to total due to rounding.

⁸ Actual Material and Construction Contractor costs exclude the cost of upsizing the pipe.

⁹ Values may not add to total due to rounding.

Final Report for La Mesa Gate Station Replacement Project

D. Disallowance

The scope of the La Mesa Gate Station Replacement Project did not include any pipe subject to disallowance under D.14-06-007 or D.15-12-020.

Final Report for La Mesa Gate Station Replacement Project

V. CONCLUSION

SDG&E enhanced the safety of their integrated natural gas transmission system by prudently executing the La Mesa Gate Station Replacement Project. Through this Replacement Project, SDG&E successfully replaced 313 feet of pipeline and completed the abandonment of 1.676 miles of pipeline in the City of La Mesa. The total loaded cost of the Project is \$5,560,106.

SDG&E executed this project prudently through coordinating the replacement of La Mesa Gate Station with the final abandonment activities of the PSEP Supply Line 49-15 Section 1 Replacement Project to avoid multiple mobilizations and line purges.

SDG&E engaged in prudent cost avoidance efforts by participating in bulk ordering of [REDACTED] pipe and reducing the need for multiple mobilizations by combining the scopes of Supply Line 49-16 and Supply Line 49-17 construction activity at La Mesa Gate Station with the Supply Line 49-15 Section 1 Abandonment Project.

End of La Mesa Gate Station Replacement Project Final Report

I. **SUPPLY LINE 49-16 REPLACEMENT AND HYDROTEST PROJECT**

A. Background and Summary

Supply Line 49-16 is a [REDACTED] diameter transmission line that runs approximately 10 miles from La Mesa to National City through residential neighborhoods and commercial areas. The pipeline is primarily routed across Class 3 locations. This report describes the activities associated with the Supply Line 49-16 Replacement and Hydrotest Project that consists of the replacement of 0.739 miles of pipeline, the hydrotest of 0.286 miles of pipeline, and the replacement of six mainline valves (MLVs) that was managed and executed in six sections. The specific attributes of this Project are detailed in Table 1 below. The total loaded cost of the Project is \$38,141,875.

The Supply Line 49-16 Replacement and Hydrotest Project was identified in the 2011 PSEP filing¹ as a Phase 1A Replacement Project. The mileage addressed by the Supply Line 49-16 Replacement and Hydrotest Project was non-contiguous and occurred across seven separate sections. SDG&E managed these sites as one project to gain efficiencies in engineering, planning, and construction activities. The Project Team coordinated the execution of the Supply Line 49-16 Replacement and Hydrotest Project with the PSEP Supply Line 49-16 Valve Enhancement Bundle that included the automation of three new MLVs.

¹ See Amended PSEP of SoCalGas and SDG&E, submitted December 2, 2011, in R.11-02-019 and subsequently transferred to A.11-11-002.

Final Report for Supply Line 49-16 Replacement and Hydrotest Project

Table 1: General Project Information

Project Name		Section 1
Project Type		Replacement
Length		544 feet
Location		National City
Class		3
MAOP (<i>confidential</i>)		[REDACTED]
Predominant Pipe Vintage		1958
Construction Start		01/08/2018
Construction Finish		01/11/2019
Original Pipe Diameter (<i>confidential</i>)		[REDACTED]
New Diameter (<i>confidential</i>)		[REDACTED]
Original SMYS ² (<i>confidential</i>)		[REDACTED]
New SMYS (<i>confidential</i>)		[REDACTED]
Project Name		Section 2
Project Type		Replacement
Length		295 feet
Location		San Diego
Class		3
MAOP (<i>confidential</i>)		[REDACTED]
Predominant Pipe Vintage		1965
Construction Start		05/02/2016
Construction Finish		08/31/2016
Original Pipe Diameter (<i>confidential</i>)		[REDACTED]
New Diameter (<i>confidential</i>)		[REDACTED]
Original SMYS ³ (<i>confidential</i>)		[REDACTED]
New SMYS (<i>confidential</i>)		[REDACTED]

² Highest percentage of Specified Minimum Yield Strength (SMYS) of Category 4 Criteria pipe.

³ Ibid.

Final Report for Supply Line 49-16 Replacement and Hydrotest Project

Table 1: General Project Information (Continued)

Project Name		Section 3	
Project Type		Replacement	
Length		220 feet	
Location		San Diego	
Class		3	
MAOP (<i>confidential</i>)		[REDACTED]	
Predominant Pipe Vintage		1968	
Construction Start		09/05/2017	
Construction Finish		09/03/2018	
Original Pipe Diameter (<i>confidential</i>)		[REDACTED]	
New Diameter (<i>confidential</i>)		[REDACTED]	
Original SMYS ⁴ (<i>confidential</i>)		[REDACTED]	
New SMYS (<i>confidential</i>)		[REDACTED]	
Project Name		Section 4	
Project Type		Replacement	
Length		636 feet	
Location		Lemon Grove	
Class		3	
MAOP (<i>confidential</i>)		[REDACTED]	
Predominant Pipe Vintage		1958	
Construction Start		08/07/2017	
Construction Finish		11/01/2017	
Original Pipe Diameter (<i>confidential</i>)		[REDACTED]	
New Diameter (<i>confidential</i>)		[REDACTED]	
Original SMYS ⁵ (<i>confidential</i>)		[REDACTED]	
New SMYS (<i>confidential</i>)		[REDACTED]	

⁴ Highest percentage of Specified Minimum Yield Strength (SMYS) of Category 4 Criteria pipe.

⁵ Ibid.

Final Report for Supply Line 49-16 Replacement and Hydrotest Project

Table 1: General Project Information (Continued)

Project Name		Section 5	
Project Type		Replacement	
Length		25 feet	
Location		Lemon Grove	
Class		3	
MAOP (<i>confidential</i>)		[REDACTED]	
Pipe Vintage		1956	
Construction Start		03/16/2015	
Construction Finish		04/13/2015	
Original Pipe Diameter (<i>confidential</i>)		[REDACTED]	
New Diameter (<i>confidential</i>)		[REDACTED]	
Original SMYS ⁶ (<i>confidential</i>)		[REDACTED]	
New SMYS (<i>confidential</i>)		[REDACTED]	
Project Name		Section 6	
Project Type		Replacement	
Length		0.478 miles	
Location		La Mesa	
Class		3	
MAOP (<i>confidential</i>)		[REDACTED]	
Pipe Vintage		1948	
Construction Start		03/13/2017	
Construction Finish		07/31/2017	
Original Pipe Diameter (<i>confidential</i>)		[REDACTED]	
New Diameter (<i>confidential</i>)		[REDACTED]	
Original SMYS ⁷ (<i>confidential</i>)		[REDACTED]	
New SMYS (<i>confidential</i>)		[REDACTED]	

⁶ Highest percentage of Specified Minimum Yield Strength (SMYS) of Category 4 Criteria pipe.

⁷ Ibid.

Final Report for Supply Line 49-16 Replacement and Hydrotest Project

Table 1: General Project Information (Continued)

Project Name		Section 7		
Project Type	Hydrotest			
Length	0.295 miles			
Location	La Mesa			
Class	3			
MAOP (<i>confidential</i>)	[REDACTED]			
Pipe Vintage	1955			
Construction Start	03/22/2016			
Construction Finish	07/28/2016			
Original Pipe Diameter (<i>confidential</i>)	[REDACTED]			
New Diameter (<i>confidential</i>)	N/A			
Original SMYS ⁸ (<i>confidential</i>)	[REDACTED]			
New SMYS (<i>confidential</i>)	N/A			
Project Costs (\$)	Capital	O&M	Total	
Loaded Project Costs	37,057,039	1,084,836	38,141,875	
Disallowed Costs	167,507	-	167,507	

⁸ Highest percentage of Specified Minimum Yield Strength (SMYS) of Category 4 Criteria pipe.

Final Report for Supply Line 49-16 Replacement and Hydrotest Project

B. Maps and Images

Figure 1: Satellite Image of Supply Line 49-16 Replacement and Hydrotest Project

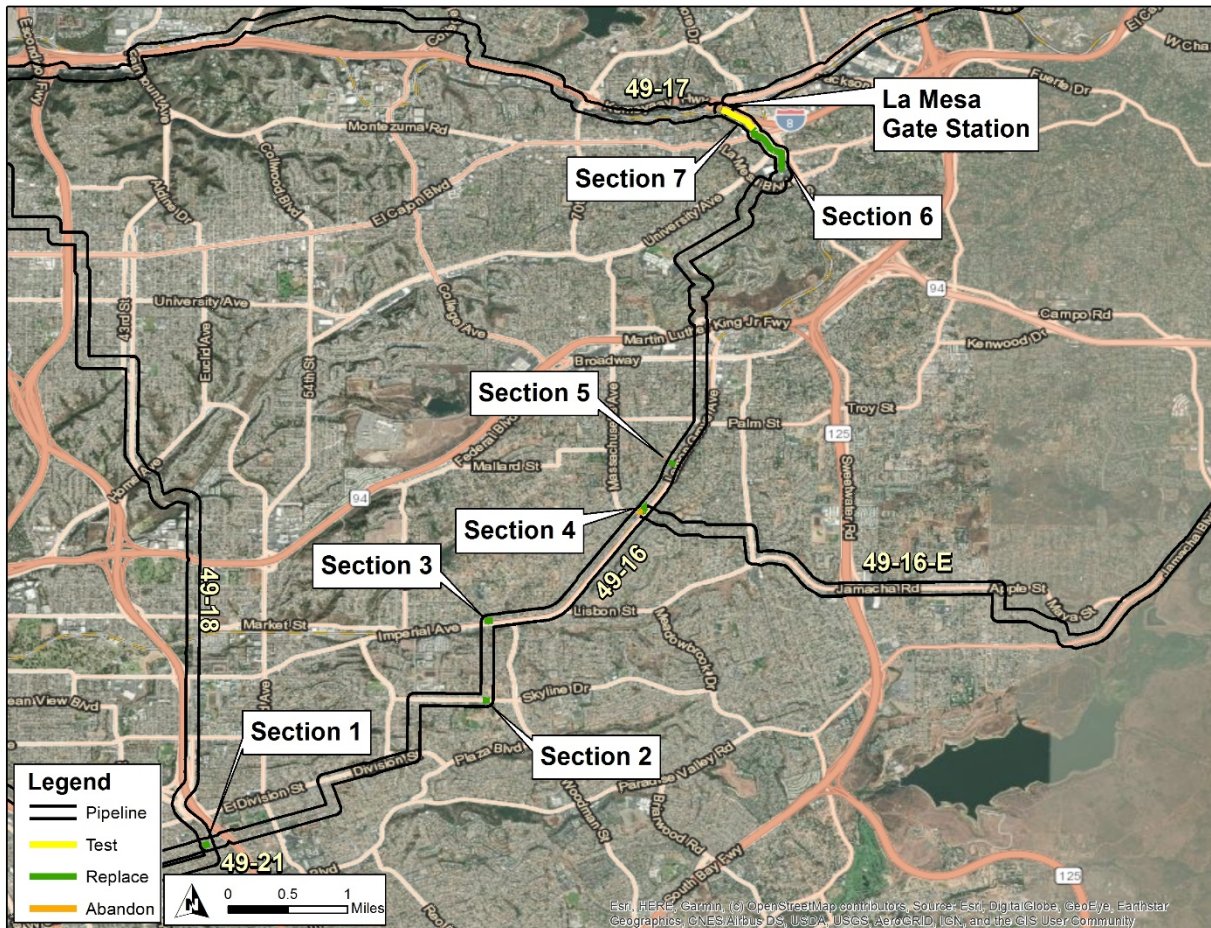

Final Report for Supply Line 49-16 Replacement and Hydrotest Project

Figure 2: Overview Map of Supply Line 49-16 Replacement and Hydrotest Project

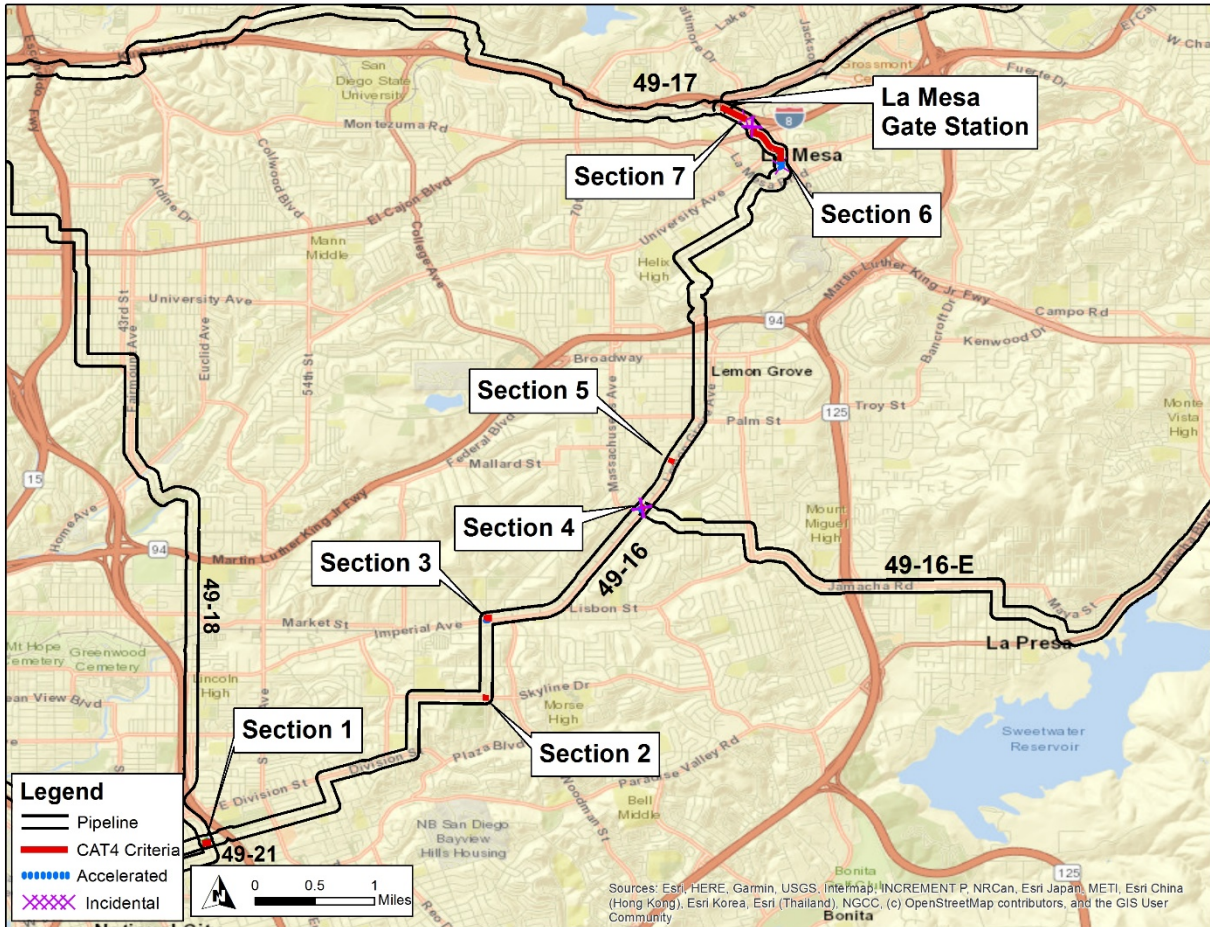

Final Report for Supply Line 49-16 Replacement and Hydrotest Project

Figure 3: Satellite Image of Supply Line 49-16 Section 1 Replacement Project



Final Report for Supply Line 49-16 Replacement and Hydrotest Project

Figure 4: Overview Map of Supply Line 49-16 Section 1 Replacement Project



Final Report for Supply Line 49-16 Replacement and Hydrotest Project

Figure 5: Satellite Image of Supply Line 49-16 Section 2 Replacement Project



Final Report for Supply Line 49-16 Replacement and Hydrotest Project

Figure 6: Overview Map of Supply Line 49-16 Section 2 Replacement Project

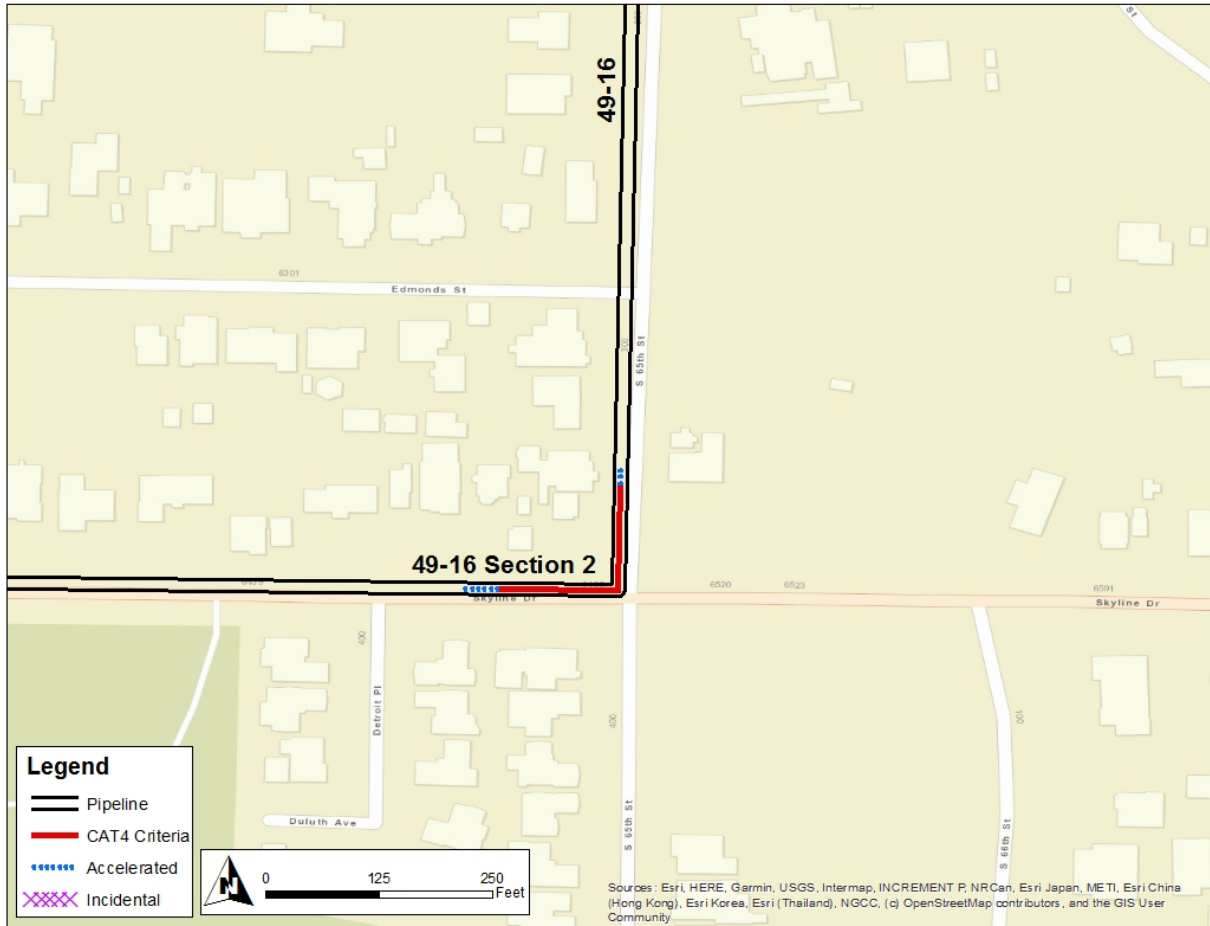

Final Report for Supply Line 49-16 Replacement and Hydrotest Project

Figure 7: Satellite Image of Supply Line 49-16 Section 3 Replacement Project



Final Report for Supply Line 49-16 Replacement and Hydrotest Project

Figure 8: Overview Map of Supply Line 49-16 Section 3 Replacement Project

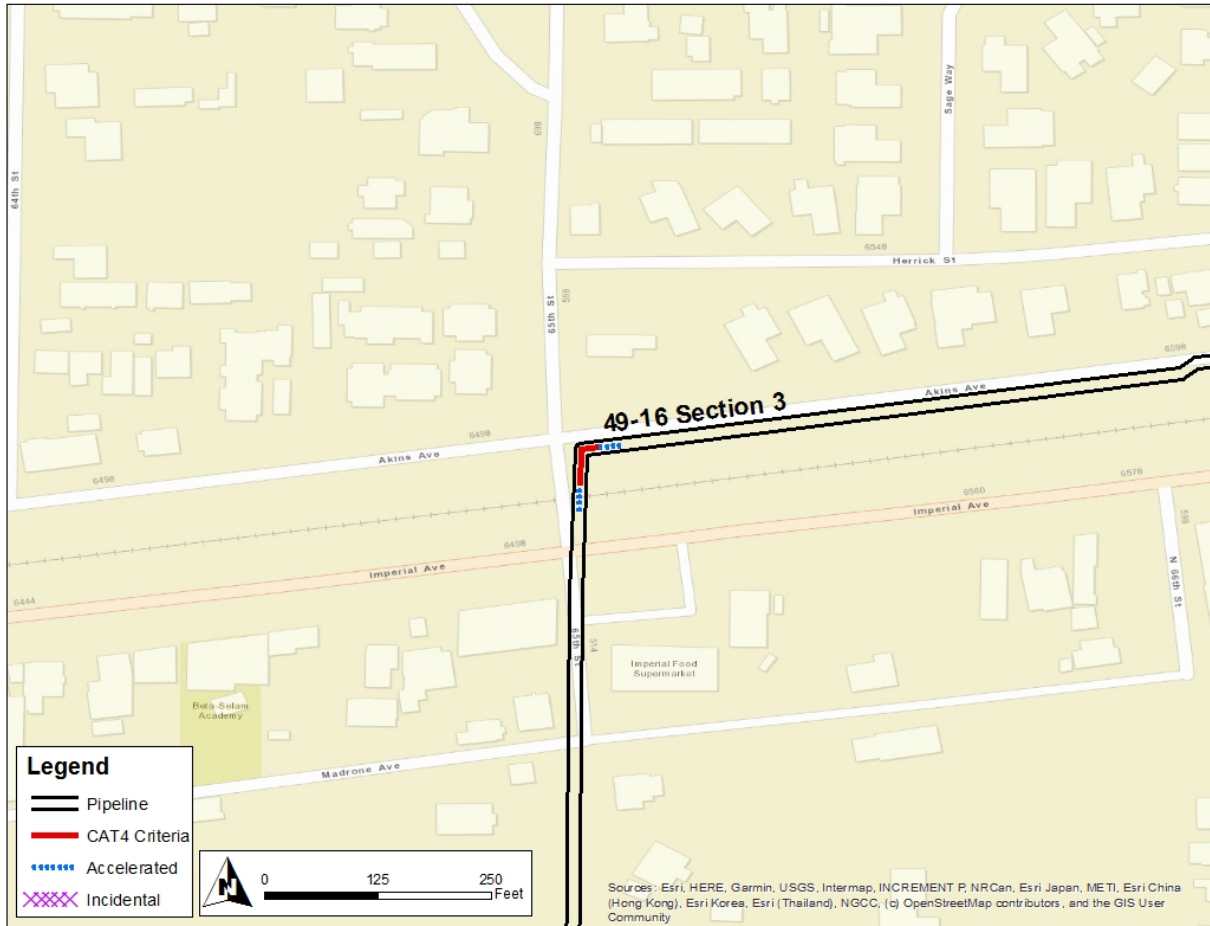

Final Report for Supply Line 49-16 Replacement and Hydrotest Project

Figure 9: Satellite Image of Supply Line 49-16 Section 4 Replacement Project

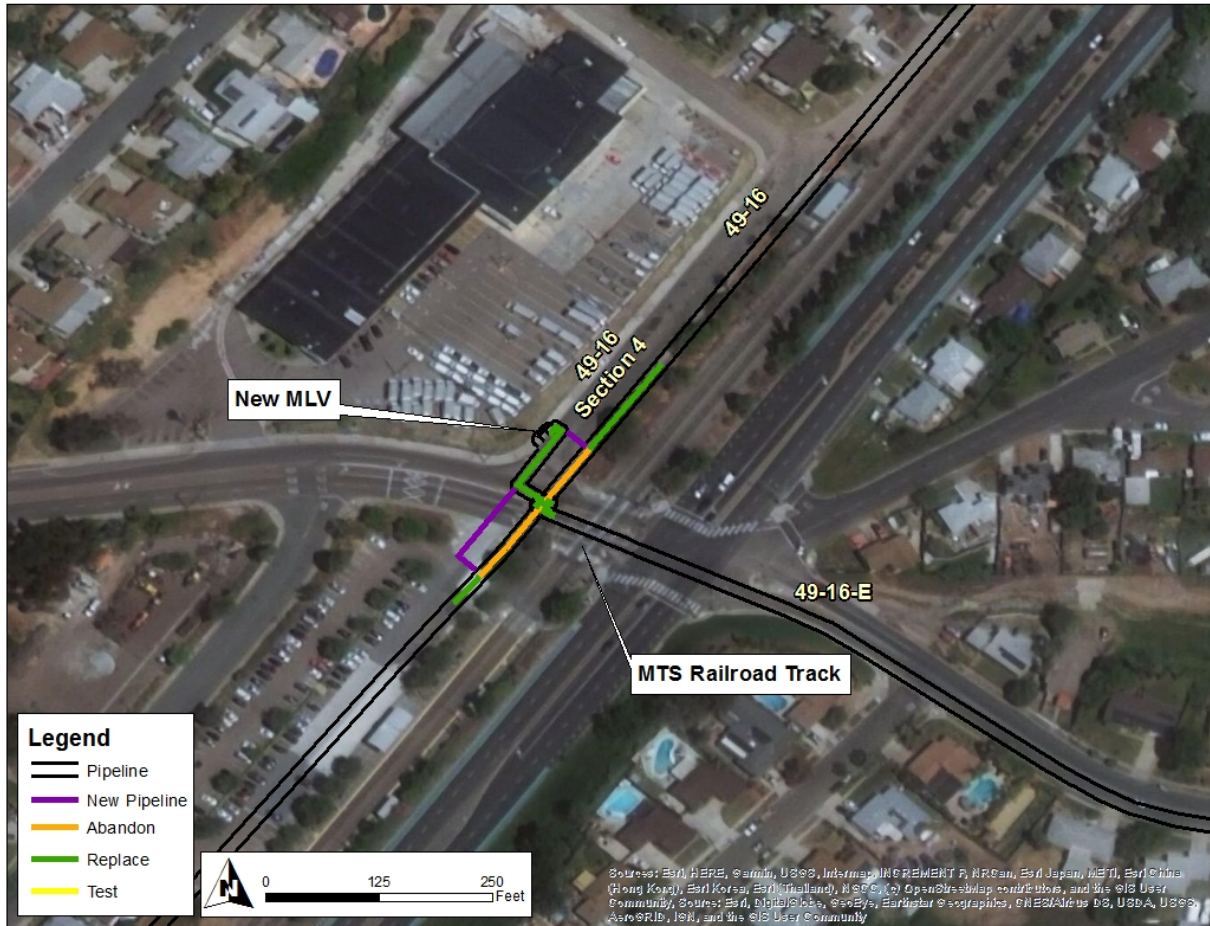

Final Report for Supply Line 49-16 Replacement and Hydrotest Project

Figure 10: Overview Map of Supply Line 49-16 Section 4 Replacement Project

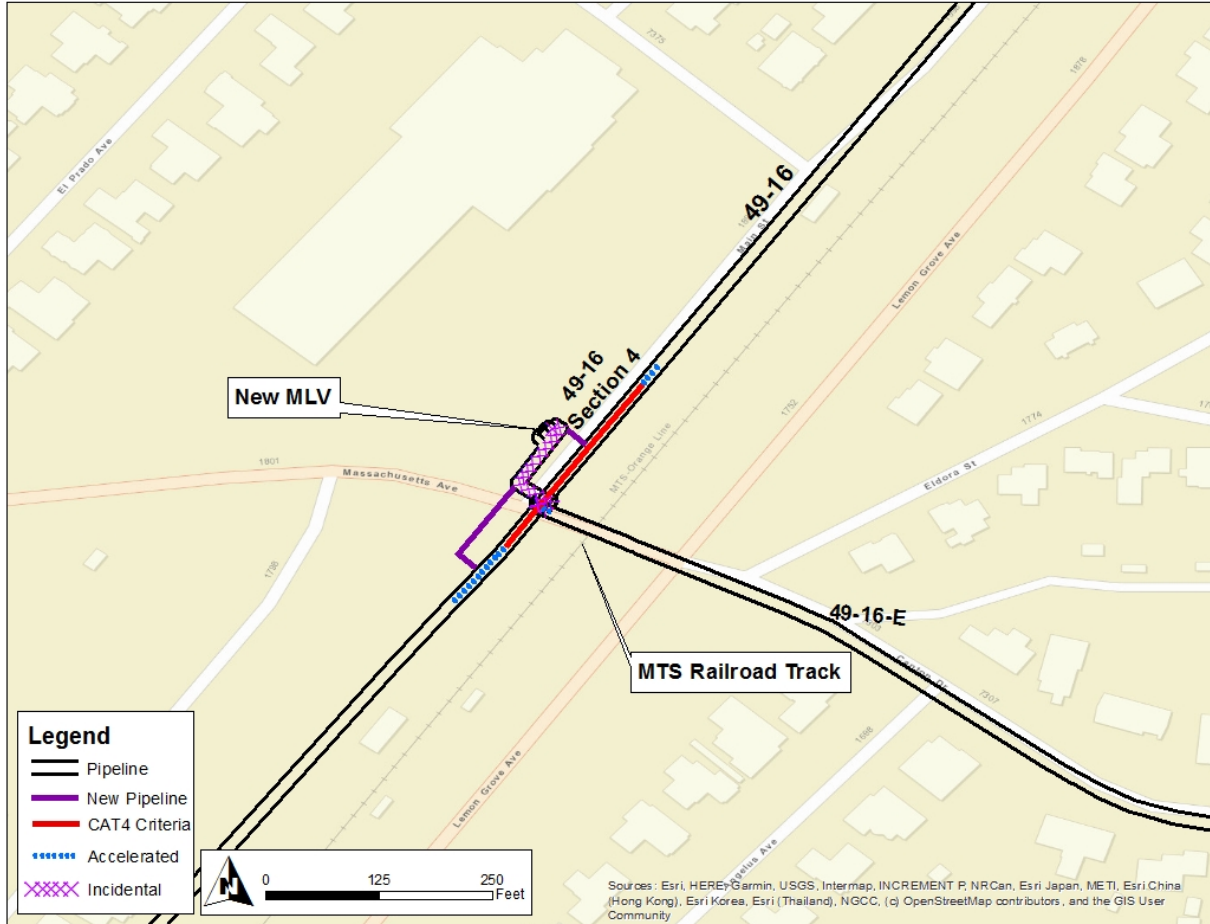

Final Report for Supply Line 49-16 Replacement and Hydrotest Project

Figure 11: Satellite Image of Supply Line 49-16 Section 5 Replacement Project



Final Report for Supply Line 49-16 Replacement and Hydrotest Project

Figure 12: Overview Map of Supply Line 49-16 Section 5 Replacement Project



Final Report for Supply Line 49-16 Replacement and Hydrotest Project

Figure 13: Satellite Image of Supply Line 49-16 Replacement and Hydrotest Project, Section 6 and Section 7



Final Report for Supply Line 49-16 Replacement and Hydrotest Project

Figure 14: Overview Map of Supply Line 49-16 Replacement and Hydrotest Project, Section 6 and Section 7

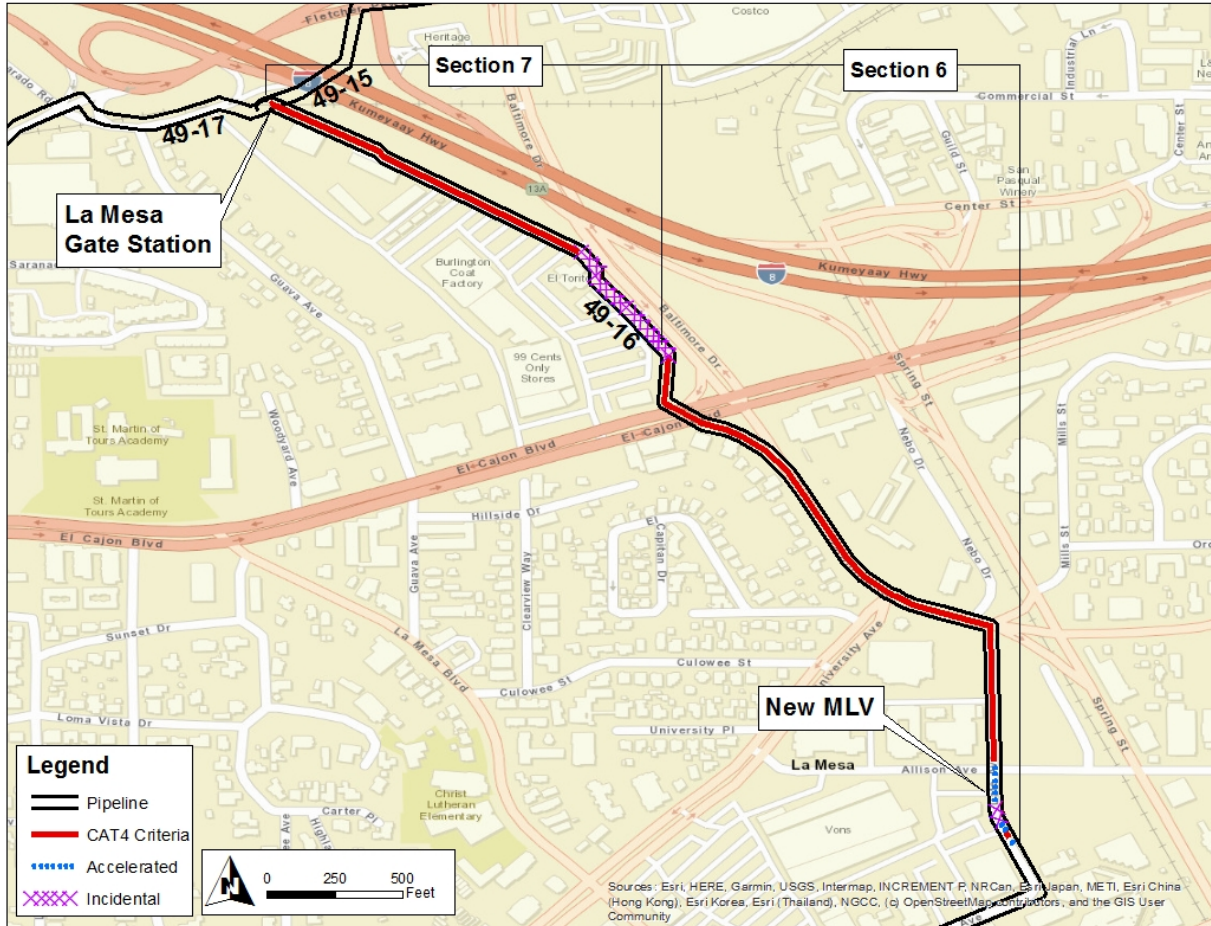

Final Report for Supply Line 49-16 Replacement and Hydrotest Project

II. ENGINEERING, DESIGN, AND PLANNING

A. Project Scope

Table 2: Mileage Information

	Criteria	Accelerated	Incidental	New	Total ⁹
Section 1	0.010 mi.	0.034 mi.	0.014 mi.	0.045 mi.	0.103 mi.
	52 ft.	180 ft.	76 ft.	236 ft.	544 ft.
Section 2	0.042 mi.	0.010 mi.	0 mi.	0.003 mi.	0.055 mi.
	223 ft.	54 ft.	0 ft.	18 ft.	295 ft.
Section 3	0.011 mi.	0.018 mi.	0 mi.	0.013 mi.	0.042 mi.
	59 ft.	95 ft.	0 ft.	66 ft.	220 ft.
Section 4	0.041 mi.	0.020 mi.	0.031 mi.	0.028 mi.	0.120 mi.
	217 ft.	104 ft.	166 ft.	149 ft.	636 ft.
Section 5 ¹⁰	0.003 mi.	0.002 mi.	0 mi.	0 mi.	0.005 mi.
	16 ft.	11 ft.	0 ft.	0 ft.	25 ft.
Section 6 ¹¹	0.394 mi.	0.044 mi.	0.056 mi.	0 mi.	0.478 mi.
	2,081 ft.	232 ft.	297 ft.	0 ft.	2,525 ft.
Section 7	0.217 mi.	0 mi.	0.078 mi.	0 mi.	0.295 mi.
	1,147 ft.	0 ft.	412 ft.	0 ft.	1,559 ft.
Final Mileage	0.719 mi.	0.128 mi.	0.180 mi.	0.073 mi.	1.099 mi.
	3,795 ft.	676 ft.	951 ft.	383 ft.	5,805 ft.

SoCalGas and SDG&E presented a conceptual project scope in workpapers supporting the 2011 PSEP filing.¹² Prior to initiating execution of the Project in 2015, SDG&E reviewed existing pipeline records to validate the scope of the Project. During the Engineering, Design, and Planning phase, SDG&E further refined the scope. This progression of the project scope is summarized as follows:

⁹ Values may not add to total due to rounding.

¹⁰ Total mileage of the completed project differs from the mileage of the pipe addressed due to realignment of the pipeline route.

¹¹ Ibid.

¹² See Amended PSEP of SoCalGas and SDG&E, submitted December 2, 2011, in R.11-02-019 and subsequently transferred to A.11-11-002.

Final Report for Supply Line 49-16 Replacement and Hydrotest Project

1. 2011 PSEP Filing: SoCalGas and SDG&E identified Supply Line 49-16 as a Phase 1A Replacement Project comprised of 0.722 miles of Category 4 Criteria pipe and 8.868 miles of Accelerated pipe.
2. Scope Validation: Through SDG&E's scope validation activities, after the 2011 filing and before initiating execution of the Project, an additional 132 feet of Category 4 Criteria pipe was determined to be within scope of the Project.
3. Engineering, Design, and Constructability:
 - a. Section 1: Supply Line 49-16 Section 1 is a replacement of 245 feet at the intersection of 4th Street and Palm Avenue. It also included the relocation and installation of two new [REDACTED] MLVs and two new [REDACTED] MLVs from the street into an SDG&E facility. The Project Team included new pipe as replacement offset parallel to the existing pipeline. The Project Team coordinated the installation of two of the new valves with the Supply Line 49-16 Valve Enhancement Bundle – 4th and Palm. The installation of the two valves identified for automation was included in the scope of the Supply Line 49-16 Replacement and Hydrotest – Section 1 work, and the automation activities were included in the scope of the Valve Enhancement Bundle.
 - b. Section 2: Supply Line 49-16 Section 2 is a replacement of 295 feet on Skyline Drive and 65th Street. The Project Team included new pipe as replacement, offset parallel to the existing pipeline.
 - c. Section 3: Supply Line 49-16 Section 3 is a replacement of 220 feet of along 65th Avenue at Akins Avenue and Imperial Avenue. Section 3 utilized jack and bore to install [REDACTED] casing pipe beneath Metropolitan Transit System (MTS) right of way (ROW) for the [REDACTED] carrier pipe. The Project Team included new pipe as replacement, offset parallel to the existing pipeline.
 - d. Section 4: Supply Line 49-16 Section 4 is a replacement of 636 feet near the intersection of Massachusetts Avenue and Main Street, the installation of a new [REDACTED] MLV with a vault, and a new [REDACTED] automated bridle assembly. The replacement included new and incidental pipe necessary to relocate a tap to

Final Report for Supply Line 49-16 Replacement and Hydrotest Project

Supply Line 49-16-E away from a railroad crossing to provide safer accessibility to the bridle valves. The Project Team coordinated the installation of one of the new valves with the Supply Line 49-16 Valve Enhancement Bundle – Massachusetts and Main. The installation of the valve identified for automation was included in the scope of the Supply Line 49-16 Replacement and Hydrotest – Section 4 work, and the automation activities were included in the scope of the Valve Enhancement Bundle.

- e. Section 5: Supply Line 49-16 Section 5 is a replacement of 26 feet of pipe near the intersection of Main Street and Beryl Street. The Project Team included incidental pipe for constructability.
 - f. Section 6: Supply Line 49-16 Section 6 is a replacement of 0.478 miles along Date Avenue and Baltimore Drive in La Mesa. Approximately 610 feet of the existing pipeline was removed and replaced in kind, and one MLV was replaced. The Project Team included incidental pipe for constructability.
 - g. Section 7: Supply Line 49-16 Section 7 is a hydrotest of 0.295 miles from the intersection of Baltimore Drive and El Cajon Blvd to La Mesa Station. The Project Team included incidental pipe for constructability.
4. Final Project Scope: The final project scope consists of a 0.286 mile Hydrotest, and six replacement projects that total 0.739 miles that included the installation of six new MLVs. The Accelerated mileage consists of 676 feet of Phase 2B pipe and 0.180 miles of incidental pipe.

B. Decision Tree Analysis

SDG&E performed a PSEP Decision Tree analysis of Supply Line 49-16 and confirmed the project design should commence as a Replacement for Sections 1, 2, 3, 4, 5, and 6, and a Hydrotest Project for Section 7.

Final Report for Supply Line 49-16 Replacement and Hydrotest Project

Segments less than 1,000 feet (Sections 1, 2, 3, 4, and 5):

Segments of less than 1,000 feet are identified for replacement under the approved PSEP Decision Tree because, for short segments of pipe, the logistical costs associated with pressure testing (for example, permitting, construction, water handling, and service disruptions for a non-looped system) can approach or exceed the cost of replacement. In such circumstances, replacement affords a more cost-effective approach to achieving compliance with D.11-06-017 while providing equal safety enhancement benefits. Moreover, installation of the new segment can usually be performed while the existing service is maintained to customers, thereby avoiding service disruptions that may otherwise occur during pressure testing.

1. Shut-In Analysis: The Project Team completed a Request for Engineering Review (RER) analysis and concluded that regulator stations within Sections 1, 2, 3, and 4 could not be shut-in during winter conditions. Section 5 could be shut-in without service disruption to customers.
2. Customer Impacts: The Project Team identified Supply Line 49-16 as the primary feed to Supply Line 49-14 and other large volume customers. The Project Team backfed Sections 1, 2, 3, and 4 to maintain uninterrupted service to the thousands of customers that are supplied by this line.
3. Piggability: Non-piggable.
4. Pipe Vintage:¹³
 - a. Section 1: 1958
 - b. Section 2: 1965
 - c. Section 3: 1968
 - d. Section 4: 1958
 - e. Section 5: 1956

¹³ Predominate Cat 4 pipeline vintage.

Final Report for Supply Line 49-16 Replacement and Hydrotest Project

5. Existing Pipe Attributes: The Project Team identified existing non-piggable features such as wrinkle bends, plug valves, large diameter taps, and pressure control fittings (PCFs) on the existing pipeline rendering the pipeline non-piggable.
6. Longseam Type: Unknown.
7. Longseam Repair History: The Project Team identified welding related anomalies identified within 1948 vintage pipe.
8. Condition of Coating: The Project Team did not identify any issues.
9. History of Leaks: Leak repairs completed in 1953, 1954, 1959, 1960, and 1963.

Segments longer than 1000 feet (Sections 6 and 7):

For pipeline segments longer than 1,000 feet in length, under the approved PSEP Decision Tree, SDG&E completes a preliminary review to determine whether SDG&E can manage customer service impacts if the pipeline segment is taken out of service for a period of two to six weeks to complete pressure testing. Where mitigation of customer impacts to remove the line from service for pressure testing is feasible, SDG&E compares the costs, constructability, risks, and benefits of pressure testing and replacement to determine whether pressure testing or replacement is the more prudent option. Through this Decision Tree analysis, SDG&E identified the replacement of Section 6 and the pressure testing of Section 7 as the most prudent options. Key considerations that support SDG&E's determination to replace Section 6 and pressure test Section 7 include:

Section 6:

1. Shut-In Analysis: The Project Team completed a Request for Engineering Review (RER) analysis and concluded that Section 6 cannot be shut-in during winter conditions.
2. Customer Impacts: The Project Team backfed Section 6 to prevent service disruptions to customers
3. Piggability: Non-piggable.

Final Report for Supply Line 49-16 Replacement and Hydrotest Project

4. Pipe Vintage:¹⁴ 1951
5. Existing Pipe Attributes: The Project Team identified multiple diameters along this portion of Supply Line 49-16 rendering the pipeline non-piggable.
6. Longseam Type: Unknown.
7. Longseam Repair History: The Project Team did not identify any issues.
8. Condition of Coating: The Project Team did not identify any issues.
9. History of Leaks: The Project Team did not identify any issues.

Section 7:

1. Shut-In Analysis: The Project Team completed a Request for Engineering Review (RER) analysis and concluded that Section 7 can be shut-in without service disruption to customers.
2. Customer Impacts: The Project Team concluded Section 7 could be taken out of service for the duration of the hydrotest project as there were no customers within the shut-in limits and an adjacent regulator station. The Project Team utilized a bridle feed to maintain uninterrupted service to customers.
3. Piggability: Piggable.
4. Pipe Vintage:¹⁵ 1955
5. Longseam Type: Unknown.
6. Longseam Repair History: The Project Team did not identify any issues.
7. Condition of Coating: The Project Team did not identify any issues.
8. History of Leaks: The Project Team did not identify any issues.

C. Engineering, Design, and Planning Factors

SDG&E reviewed pipeline drawings and other information, contacted internal planning groups, communicated with external stakeholders, conducted survey activities, including reviewing public records and potholing of the area to confirm the presence of underground

¹⁴ Predominated Cat 4 pipeline vintage.

¹⁵ Ibid.

Final Report for Supply Line 49-16 Replacement and Hydrotest Project

utilities and substructures, and completed a pre-design site walk. Key factors that influenced the engineering and design of the Project are as follows for Sections 1, 2, 3, 4, and 5:

1. Shut-In Analysis: As discussed above, the Project Team completed an RER analysis and concluded that regulator stations within Sections 1, 2, 3, and 4 could not be shut-in during winter conditions. Section 5 can be shut-in without service disruption.
2. Customer Impact: Per the RER, the Project Team identified that Supply Line 49-16 is the primary feed to Supply Line 49-14, some critical and several major noncore customers. The Project Team backfed Sections 1, 2, 3, and 4 to maintain uninterrupted service to customers.
3. Community Impact: The location of the project is in a very busy commercial and residential area that required extensive traffic control measures and work restrictions to mitigate construction impact to business and residents along the construction routes. Notable locations where mitigation strategies were especially necessary are as follows:
 - a. Section 3:
 - i. The Project Team utilized a jack and bore to cross Imperial Avenue to mitigate traffic impact and avoid extended road closures.
 - ii. The Project Team identified several businesses, churches, an elementary school, and an MTS station near this construction site.
 - b. Section 4: The Project Team identified an MTS station near this construction site.
4. Known Substructures: At the Section 3 construction site, the Project Team identified a sewer line that conflicted with the installation of the new pipeline. To resolve the conflict, the Project Team installed a temporary sewer bypass prior to executing the jack and bore activities.
5. Permit Conditions:

Final Report for Supply Line 49-16 Replacement and Hydrotest Project

- a. Section 1: The Project Team obtained encroachment, grading, and site demolition permits from National City. The Project Team worked with National City to develop a Traffic Control Plan (TCP).
- b. Section 2: The Project Team worked with the City of San Diego to develop a TCP.
- c. Section 3:
 - i. The Project team obtained an encroachment permit and a noise variance permit from the City of San Diego. The Project Team worked with the City of San Diego to develop and obtain an approved TCP.
 - ii. The Project Team obtained an encroachment permit from the MTS. The Project Team worked with the MTS to develop and obtain an approved TCP.
- d. Section 4:
 - i. During the permitting process, protracted negotiations and design revisions associated with the City of Lemon Grove's review delayed the construction start. The issues brought forth by the City of Lemon Grove were ultimately resolved and the Project Team obtained an encroachment permit.. The Project Team also worked with the City of Lemon Grove to develop and obtain an approved TCP.
 - ii. The Project Team obtained an encroachment permit from the MTS. The Project Team worked with the MTS to develop and obtain an approved TCP.
 - iii. The Project Team worked with the City of San Diego to develop and obtain an approved TCP.
- e. Section 5: The Project Team obtained an encroachment permit from the City of Lemon Grove. The Project Team worked with the City of Lemon Grove to develop and obtain an approved TCP.

Final Report for Supply Line 49-16 Replacement and Hydrotest Project

6. Constructability:
 - a. Section 3: The Project Team utilized a jack and bore to install a 36-inch diameter casing pipe beneath MTS ROW for the [REDACTED] diameter carrier pipe.
 - b. Section 5: The Project Team prefabricated and pretested this section of pipeline above ground, prior to installation, due to the short length of this section.
7. Land Use: The Project Team utilized the same laydown and prefabrication yards for Sections 2, 3, 4, 5, and 6 due to the general proximity of the project sites.
8. Environmental: The Project Team determined that the pipeline coating likely contained asbestos and planned for abatement activities wherever existing pipe was to be exposed.
9. Valves: The Project Team replaced five preexisting MLVs.
 - a. Section 1: The Project Team coordinated the installation of two of the new valves with the Supply Line 49-16 Valve Enhancement Bundle – 4th and Palm. The installation of the two valves identified for automation were included in the scope of the Supply Line 49-16 Replacement and Hydrotest – Section 1 work and the automation activities were included in the scope of the Valve Enhancement Bundle.
 - b. Section 4: The Project Team coordinated the installation of one of the new valves with the Supply Line 49-16 Valve Enhancement Bundle – Massachusetts and Main. The installation of the one valve identified for automation was included in the scope of the Supply Line 49-16 Replacement and Hydrotest – Section 4 work and the automation activities were included in the scope of the Valve Enhancement Bundle.

Section 6:

1. Shut-In Analysis: The Project Team completed an RER and concluded that two regulator stations are supplied by Section 6 cannot be shut-in during winter conditions.

Final Report for Supply Line 49-16 Replacement and Hydrotest Project

2. Customer Impact: The RER stated that Supply Line 49-16 is the primary feed to Supply Line 49-14, some critical and several major noncore customers. The Project Team backfed Section 6 to maintain uninterrupted service to customers.
3. Community Impact: The location of this project is in a very busy commercial and residential area that required extensive traffic control measures and work restrictions to mitigate construction impact to business, residents, public service entities, and schools along the construction route
4. Known Substructures: The Project Team performed potholing of the area and identified multiple substructures along the replacement route.
5. Permit Conditions:
 - a. The Project Team obtained an Encroachment Permit from the City of La Mesa.
 - b. The Project Team worked with Caltrans and the City of La Mesa to develop and obtain an approved TCP.
6. Land Use: The Project Team utilized the same laydown and prefabrication yards for Sections 2, 3, 4, 5, and 6 due to the general proximity of the Project sites.
7. Environmental: The Project Team determine that the pipeline coating likely contained asbestos and planned for abatement activities wherever existing pipe was to be exposed.
8. Valves: The Project Team replaced one preexisting, non-piggable, MLV.
9. Constructability: Approximately 610 feet of the existing pipeline was removed to allow for the placement of the new pipeline within the existing ROW due to limitations in the available construction area and the lack of expanded easement availability.

Section 7:

1. Shut-In Analysis: The Project Team completed an RER analysis and concluded that Section 7 could be shut-in without service disruption.
2. Customer Impact: The RER identified Supply Line 49-16 as the primary feed to Supply Line 49-14, serving critical noncore customers. Section 7 could be taken out of service

Final Report for Supply Line 49-16 Replacement and Hydrotest Project

for the duration of the hydrotest project. The Project Team utilized a bridle feed to maintain uninterrupted service to customers.

3. Community Impact: The location of this project is in a very busy commercial and residential area that required extensive traffic control measures and work restrictions to mitigate construction impact to business and residents along the construction route.
4. Known Substructures: The Project Team performed potholing of the area and identified multiple substructures.
5. Permit Conditions: The Project Team obtained traffic control permits from the City of La Mesa and Caltrans and a Letter of Consideration from the MTS.
6. Environmental: The Project Team determine that the pipeline coating likely contained asbestos and planned for abatement activities wherever existing pipe was to be exposed.

D. Scope Changes

Through engineering, design, and planning activities, SDG&E determined that changes in scope were appropriate to enhance the design of the Project and address engineering factors. As a result, the scope of work that the preliminary cost estimate was based on does not fully reflect the final scope. Summarized below are notable changes in scope made after the preliminary cost estimate was developed and approved.

Section 3:

The Project Team revised the design of the jack and bore crossing Imperial Avenue due to a conflicting storm drain.

Section 4:

The Project Team revised the design several times to accommodate the City of Lemon Grove's requirements described below:

1. The City of Lemon Grove required that the new pipeline near the sidewalk be at a depth of seven feet. The original design called for a depth of five feet.

Final Report for Supply Line 49-16 Replacement and Hydrotest Project

2. The Project Team designed the Project to account for a park planned by the City of Lemon Grove. After the development of the preliminary estimate, City of Lemon Grove altered the park design resulting in a rerouted alignment and redesign of the pipeline.
3. The City of Lemon Grove requested additional changes to the design that included the addition of a utility pole and mounted radio antenna for pipeline automation equipment.

Final Report for Supply Line 49-16 Replacement and Hydrotest Project

III. CONSTRUCTION

A. Construction Contractor Selection

The Project Team prepared an initial cost estimate based on the preliminary design. Following completion of the more detailed engineering, design, and planning activities described above, the Project Team directed the Performance Partner contractor to prepare cost estimates based on the more detailed engineering design package, that included the updated design described in the discussion of notable Scope Changes above. SDG&E awarded the construction contract to the Performance Partner.

1. SDG&E’s Preliminary Construction Cost Estimate (confidential): SDG&E’s preliminary cost estimate for construction was [REDACTED].
2. Construction Contractor’s Target Price Estimate (confidential): The Construction Contractor’s cost estimate was [REDACTED], that was [REDACTED] than SDG&E’s preliminary cost estimate for construction.

B. Construction Schedule

Table 3: Construction Timeline

Section 1	
Construction Start	01/08/2018
Construction Completion	01/11/2019
NOP Date	05/08/2018
Section 2	
Construction Start	05/02/2016
Construction Completion	08/31/2016
NOP Date	07/11/2016
Section 3	
Construction Start	09/05/2017
Construction Completion	09/03/2018
NOP Date	01/05/2018

Final Report for Supply Line 49-16 Replacement and Hydrotest Project

Section 4	
Construction Start	08/07/2017
Construction Completion	11/01/2017
NOP Date	10/12/2017
Section 5	
Construction Start	03/16/2015
Construction Completion	04/13/2015
NOP Date	07/11/2016
Section 6	
Construction Start	03/13/2017
Construction Completion	07/31/2017
NOP Date	06/15/2017
Section 7	
Construction Start	03/22/2016
Construction Completion	07/28/2016
NOP Date	07/11/2016

Final Report for Supply Line 49-16 Replacement and Hydrotest Project

C. Changes During Construction

SDG&E successfully mitigated conditions during construction in a manner that minimized significant impacts on project scope, cost, and schedule. As a result, these conditions did not result in any notable change orders.

Final Report for Supply Line 49-16 Replacement and Hydrotest Project

Figure 3: Section 3 Bore Pit with Boring Machine Track System



Final Report for Supply Line 49-16 Replacement and Hydrotest Project

Figure 4: Section 4 Hydrotesting of a Prefabricated Installation



Final Report for Supply Line 49-16 Replacement and Hydrotest Project

Figure 5: Section 4 Trenching near New MLV Location



Final Report for Supply Line 49-16 Replacement and Hydrotest Project

Figure 6: Section 6 Test Head in the Foreground, Temporary Pigging Equipment in the Background



Final Report for Supply Line 49-16 Replacement and Hydrotest Project

D. Commissioning and Site Restoration

Commissioning activities include restoration of the site, final inspection and placement of the pipeline back into service, transportation and disposal of hydrotest water and hazardous material, and site demobilization. Closeout activities include development of final drawings, finalization of a reconciliation package, and updates to company recordkeeping systems to reflect the completed scope of work.

IV. PROJECT COSTS

A. Cost Avoidance Actions

SDG&E exercised due diligence in the planning, design, and construction activities for this project to minimize or avoid costs when prudent to do so. As discussed above, the Project Team conducted a site visit to identify and incorporate discernible site conditions into the engineering, design, and planning of the Project. Specific examples of cost avoidance actions taken on this project are:

1. Land Use: The Project Team utilized the same laydown and prefabrication yards for Sections 2, 3, 4, 5, and 6 due to the general proximity of the Project sites avoiding the cost of renting, setting up and operating multiple yards.
2. Materials: The Project Team ordered 16-inch piping in bulk.
3. Future Maintenance: The Project Team installed a casing vent at the Section 3 site in the center median to allow for easier and safer access to the vent.
4. Construction Execution: The Project Team relocated southern tie-in point for Section 4 from beneath a concrete pad to a grassy area reducing construction and restoration costs.

B. Cost Estimate

Once the primary elements of the project scope were confirmed and engineering, design, and planning activities were underway, SDG&E prepared an estimate of the Direct Costs of the Project in the amount of \$24,380,658, based on the preliminary design. The Project Team considered the conditions known at the time to prepare the preliminary Direct Cost estimate. This estimate reflects the projected Labor, Material, and Services costs anticipated to be incurred to execute the Project.

SDG&E estimated Indirect Costs of the Project based on the estimated Direct Costs and other project-related variables.

Final Report for Supply Line 49-16 Replacement and Hydrotest Project

C. Actual Direct and Indirect Costs

Actual Direct Costs reflect the Labor, Material, and Services costs incurred to execute the Project. Actual Indirect Costs reflect costs for incremental overhead loaders in accordance with Company overhead allocation policies. The total loaded cost of the Project is \$38,141,875.

Table 4: Estimated and Actual Direct Costs and Variances¹⁶

Direct Costs (\$)	Estimate	Actuals ¹⁷	Delta Over/(Under)
Company Labor	1,079,322	985,843	(93,479)
Materials	1,261,514	945,788	(315,726)
Construction Contractor	14,949,297	15,779,144	829,847
Construction Management & Support	945,344	2,180,833	1,235,489
Environmental	412,639	1,392,863	980,224
Engineering & Design	1,910,722	7,864,701	5,953,979
Project Management & Services	811,460	1,095,398	283,938
ROW & Permits	978,638	1,227,839	249,201
GMA	2,031,722	1,853,598	(178,124)
Total Direct Costs	24,380,658	33,326,008	8,945,350

Table 5: Estimated and Actual Indirect Costs, Total Costs, and Variances¹⁸

Indirect Costs/Total Costs (\$)	Estimate	Actuals	Delta Over/(Under)
Overheads	3,576,547	3,679,831	103,284
AFUDC	3,446,456	963,420	(2,483,036)
Property Taxes	0	172,617	172,617
Total Indirect Costs	7,023,003	4,815,867	(2,207,136)
Total Direct Costs	24,380,658	33,326,008	8,945,350
Total Loaded Costs	31,403,661	38,141,875	6,738,214

¹⁶ Values may not add to total due to rounding.

¹⁷ Actual Material and Construction Contractor costs exclude the cost of upsizing the pipe.

¹⁸ Values may not add to total due to rounding.

Final Report for Supply Line 49-16 Replacement and Hydrotest Project

D. Disallowance

For this project, SDG&E identified 520 feet of pipe as being installed after 1955 and lacking records that provide the minimum information necessary to demonstrate compliance with then-applicable industry standards or regulatory strength testing and recordkeeping requirements. Of the pipeline that was replaced, 520 feet of post-1955 are disallowed. Therefore, a \$167,507 reduction to ratebase was calculated by multiplying 0.098 miles of pipe by \$1,709,257 million per mile, which was SoCalGas and SDG&E's system average cost of pressure testing at the time the pipeline was returned to service.

V. CONCLUSION

SDG&E enhanced the safety of their integrated natural gas transmission system by prudently executing the Supply Line 49-16 Replacement and Hydrotest Project. Through this Replacement and Hydrotest Project, SDG&E successfully hydrotested 0.286 miles of pipeline and replaced 0.739 miles of pipeline in the Cities of National City, San Diego, Lemon Grove, and La Mesa. The total loaded cost of the Project is \$38,141,875.

SDG&E executed this project prudently through designing and executing the Project to support achievement of the Pipeline Safety Enhancement Plan objectives. SDG&E adhered to all permit requirements for site restoration and completed work in accordance with permit requirements for traffic control and work hours that minimized impacts to the community

SDG&E engaged in prudent cost avoidance efforts to complete this project at a reasonable cost by carefully planning and coordinating engineering and construction activities to maximize efficiencies and reduce customer and community impacts, engaging in reasonable efforts to promote competitive and market based rates for contractor services and materials, and by using a reasonable amount of company and contractor resources to complete this projects as soon as practicable.

End of Supply Line 49-16 Replacement and Hydrotest Project Final Report

I. SUPPLY LINE 49-28 ABANDONMENT PROJECT

A. Background and Summary

Supply Line 49-28 is a predominantly [REDACTED] diameter supply line that runs approximately 7.3 miles along Interstate 5, through residential neighborhoods and commercial areas in the City of San Diego. The pipeline was primarily routed across a Class 3 location. This Project represents the abandonment activities for the Supply Line 49-28 Replacement Project.¹ The abandoned pipeline crossed under Interstate 5 and required grout filling of three crossings in Caltrans right of way (ROW). Execution of the abandonment of the crossings was delayed due to unusually long lead times in obtaining Caltrans permit approvals.

This report describes the activities associated with Supply Line 49-28 Abandonment Project which consists of the grout filling of three crossings, the removal of one mainline valve (MLV), and the removal of one existing regulator station. The specific attributes of this Project are detailed in Table 1 below. The total loaded cost of the Project is \$2,379,002.

¹ Supply Line 49-28 Replacement Project was authorized for recovery in Decision D.20-08-034.

Final Report for Supply Line 49-28 Abandonment Project

Table 1: General Project Information

Project Name		Supply Line 49-28 Abandonment		
Project Type	Abandonment			
Length	N/A			
Location	San Diego			
Class	3			
MAOP (<i>confidential</i>)	[REDACTED]			
Pipe Vintage	1932			
Construction Start ²	11/27/2017			
Construction Finish	03/01/2019			
Original Pipe Diameter (<i>confidential</i>)	[REDACTED]			
New Diameter (<i>confidential</i>)	N/A			
Original SMYS ³ (<i>confidential</i>)	[REDACTED]			
New SMYS (<i>confidential</i>)	N/A			
Project Costs (\$)	Capital	O&M	Total	
Loaded Project Costs	2,379,002	-	2,379,002	
Disallowed Costs	-	-	-	

² For Supply 49-28 Abandonment Project, Construction Start is the initiation date of the remaining abandonment activities.

³ Highest percentage of Specified Minimum Yield Strength (SMYS) of Category 4 Criteria pipe.

Final Report for Supply Line 49-28 Abandonment Project

B. Maps and Images

Figure 1: Satellite Image of Supply Line 49-28 Abandonment Project

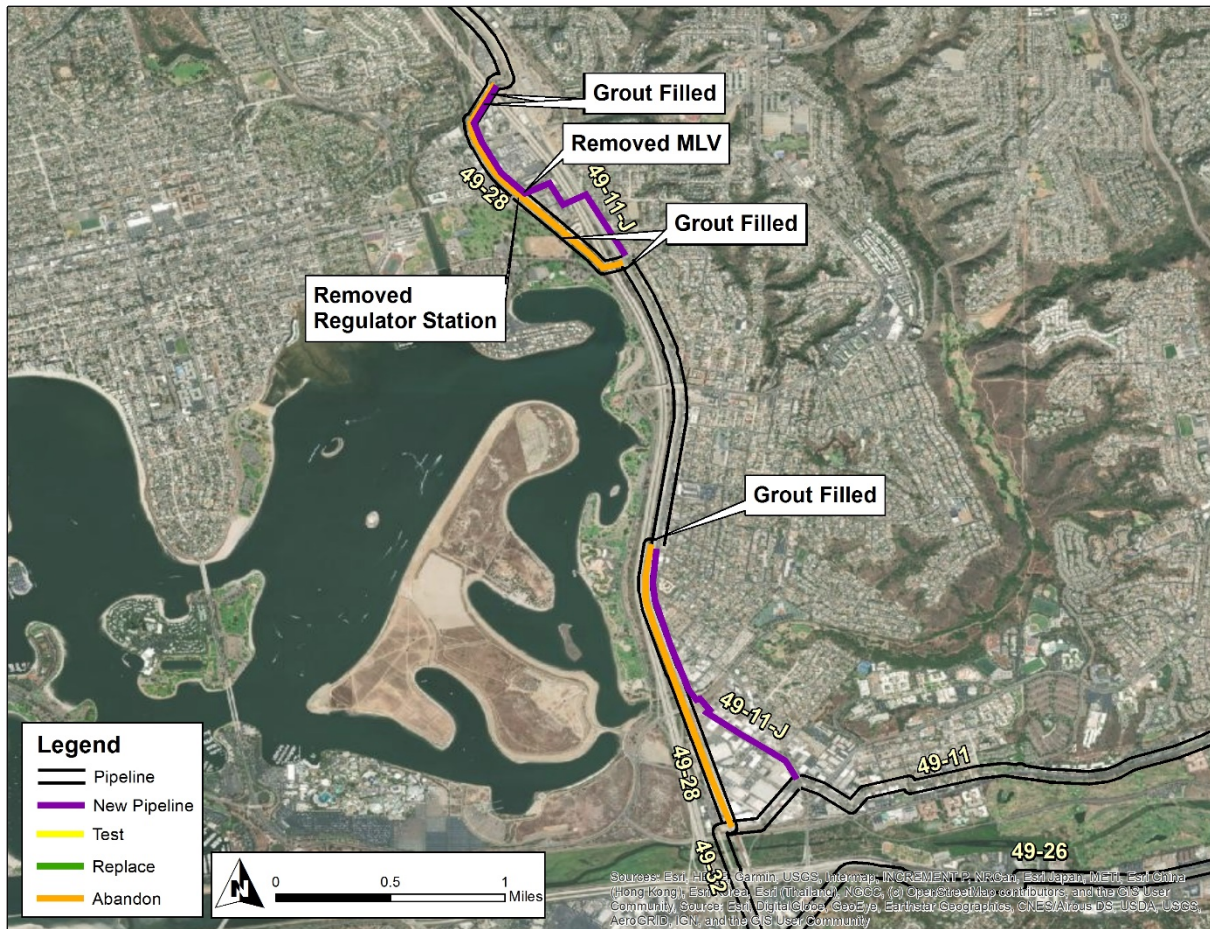

Final Report for Supply Line 49-28 Abandonment Project

Figure 2: Overview Map of Supply Line 49-28 Replacement Project

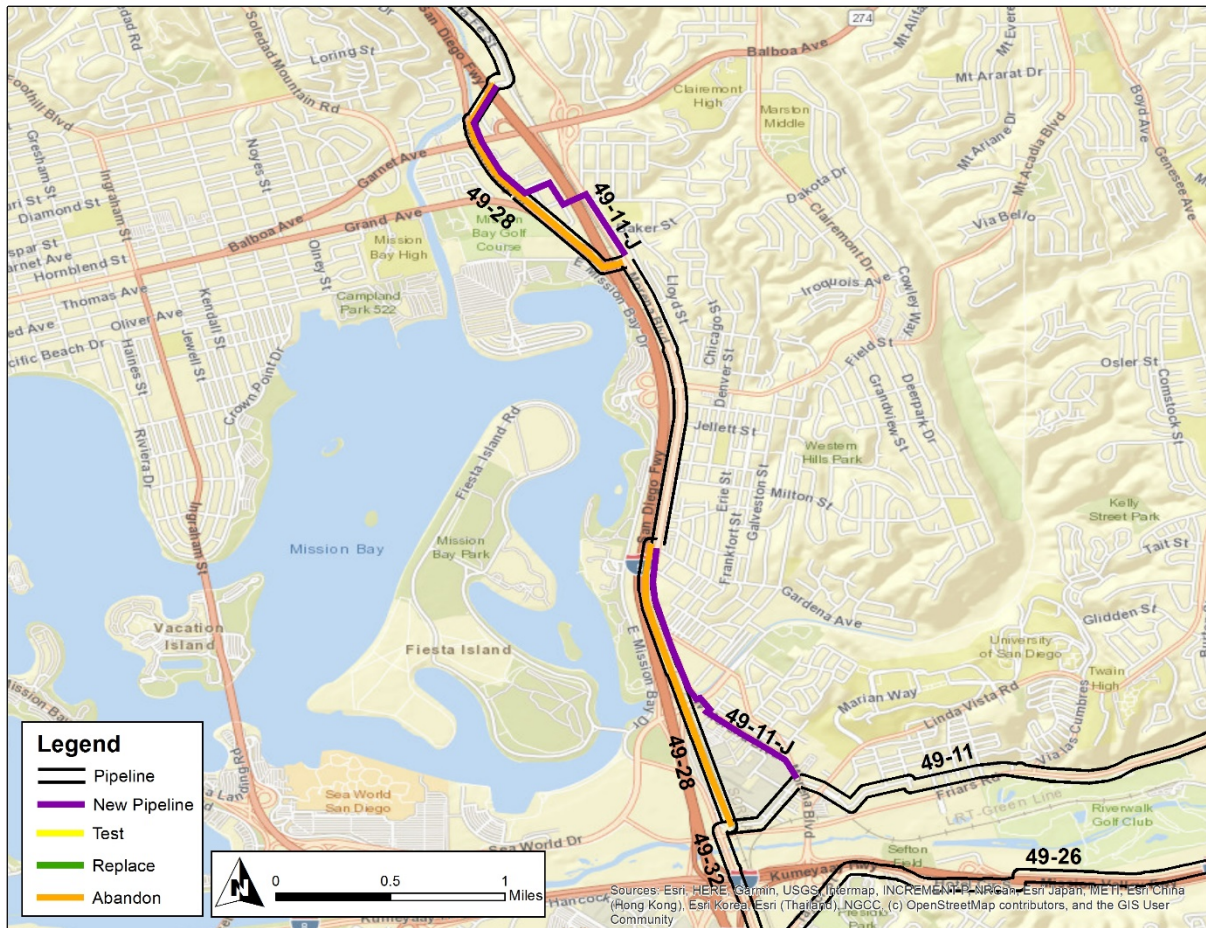

II. ENGINEERING, DESIGN, AND PLANNING

A. Project Scope

Table 2: Mileage Information⁴

	Criteria	Accelerated	Incidental	New	Total
Final Mileage	N/A	N/A	N/A	N/A	N/A
	N/A	N/A	N/A	N/A	N/A

SoCalGas and SDG&E presented a conceptual project scope in workpapers supporting the 2011 PSEP filing.⁵ Prior to initiating execution of the Project in 2017, SDG&E reviewed existing pipeline records to validate the scope of the Project. During the Engineering, Design, and Planning phase, SDG&E further refined the scope. This progression of the project scope is summarized as follows:

1. 2011 PSEP Filing: SoCalGas and SDG&E identified Supply Line 49-28 as a Phase 1A Replacement Project comprised of 1.796 miles of Category 4 Criteria pipe and 3.099 miles of Accelerated pipe.
2. Scope Validation: Through scope validation activities, SDG&E established the abandonment scope for the Supply Line 49-28 Abandonment Project.
3. Engineering, Design, and Constructability:
 - a. The Project Team completed the rerouted installation of the North Section of Supply Line 49-28 Replacement Project and once service to all customers were connected to the new line, they abandoned and purged the gas from the preexisting pipeline section

⁴ The PSEP Criteria mileage associated with Supply Line 49-28 was accounted for in the Supply Line 49-28 Replacement Project included for reasonableness review in Application 18-11-010.

⁵ See Amended PSEP of SoCalGas and SDG&E, submitted December 2, 2011, in R.11-02-019 and subsequently transferred to A.11-11-002.

Final Report for Supply Line 49-28 Abandonment Project

- b. The remaining abandonment activities of the Supply Line 49-28 Replacement Project - North Section were postponed due to delays in acquiring Caltrans permits. Activities included the grout filling at three crossings, removal of one MLV, and removal of one regulator station.
4. Final Project Scope: The final project scope consists of the grout filling of three crossings, the removal of one MLV, and the removal of one existing regulator station.

B. Decision Tree Analysis

SDG&E performed a PSEP Decision Tree analysis of Supply Line 49-28 and confirmed the project design should commence as a Replacement Project.⁶ The abandonment of preexisting pipeline was not subject to a decision tree analysis. It is the final step at the conclusion of a pipeline replacement.

C. Engineering, Design, and Planning Factors

As part of the Supply Line 49-28 Replacement Project, SDG&E reviewed pipeline drawings and other information, contacted internal planning groups, communicated with external stakeholders, conducted survey activities including reviewing public records and potholing of the area to confirm the presence of underground utilities and substructures, and completed a pre-design site walk. Subsequently, the Project Team determined that the post completion abandonment of the North Section of the project had to be delayed pending receipt of Caltrans permits.

Key factors that influenced the engineering and design of the Abandonment Project are as follows:

1. Permit Conditions: Permits were required from the City of San Diego and Caltrans for encroachment, noise, and traffic control. Caltrans rejected the initial project plans, which resulted in multiple revisions requiring additional engineering.

⁶ Please refer to the workpapers submitted with A.18-11-010 for the complete description of the Decision Tree Analysis performed for 49-28 Replacement Project.

Final Report for Supply Line 49-28 Abandonment Project

2. Constructability: Remaining abandonment activities were delayed pending receipt of permits. This included grout filling at three crossings as required per the permits and removal of one MLV. Grout filling activity includes excavation of the abandoned pipe, the installation of grout filling equipment, and welding and plating of pipe ends.
3. Shut-In Analysis: The pipeline was capped and purged of gas as part of the Supply Line 49-28 Replacement Project and all preexisting customers were tied over to the new pipeline.
4. Customer Impact: The Project Team did not identify any anticipated service disruptions to customers.
5. Community Impact: The Project Team utilized traffic control at the construction sites.
6. Known Substructures: The Project performed potholing of the area and identified multiple substructures.
7. Land Use: The Project used SDG&E property for the laydown yard.
8. Environmental:
 - a. The Project Team identified multiple vegetated areas that required restoration after the completion of excavation activities.
 - b. The shelter for the automation equipment at the regulator station contained asbestos and required abatement to remove it.

D. Scope Changes

SDG&E did not make any notable scope changes during detailed design.

III. CONSTRUCTION

A. Construction Contractor Selection

The Project Team directed the Performance Partner to prepare cost estimates based on the final engineering design package. SDG&E awarded the construction contract to the Performance Partner.

1. SDG&E’s Construction Cost Estimate (*confidential*): SDG&E’s cost estimate based on the Work Order Authorization (WOA) was [REDACTED].
2. Construction Contractor’s Target Price Estimate (*confidential*): The Construction Contractor’s cost estimate was [REDACTED], which was [REDACTED] than SDG&E’s WOA.

B. Construction Schedule

Table 3: Construction Timeline

Construction Start Date ⁷	11/27/2017
Construction Completion Date	03/01/2019

C. Changes During Construction

The conditions summarized below were encountered during construction. Activities to address or mitigate these conditions resulted in approximately \$203,000 in change orders.

1. Field Design Changes:
 - a. The Construction Contractor provided additional support for traffic control, excavating and exposing the existing pipeline to install electrolysis test stations

⁷ For Supply 49-28 Abandonment Project, Construction Start is the initiation date of the remaining abandonment activities.

Final Report for Supply Line 49-28 Abandonment Project

(ETS), backfill of the excavations, and restoration of the road surface back to original condition.

- b. The Construction Contractor provided additional pipeline abandonment support following Caltrans requirement to grout fill the casing and carrier pipe crossing at a heavily trafficked intersection.

Final Report for Supply Line 49-28 Abandonment Project

Figure 4: Sawcutting to Access the Abandoned Pipeline for Grout Fill



Final Report for Supply Line 49-28 Abandonment Project

Figure 5: Grout Filling the Abandoned Pipeline



Final Report for Supply Line 49-28 Abandonment Project

Figure 6: Grout Test Samples



Final Report for Supply Line 49-28 Abandonment Project

D. Decommissioning and Site Restoration

Decommissioning activities included site restoration, final inspections, cut and weld plates on the abandoned lines, the installation of weld caps on the active lines, disposal of hazardous material, and demobilization from the site. Closeout activities included development of final drawings, finalization of a reconciliation package, and updates to company recordkeeping systems to reflect the completed scope of work.

IV. PROJECT COSTS

A. Cost Avoidance Actions

SDG&E exercised due diligence in the planning, design, and construction activities for this project to minimize or avoid costs when prudent to do so. As discussed above, the Project Team conducted a site visit to identify and incorporate discernible site conditions into the engineering, design, and planning of the Project. An example of a cost avoidance action taken on this project was the Project Team's use of SDG&E property for the laydown yard avoiding the cost of leasing additional land.

B. Cost Estimate

The Project Team developed a high level estimate for the new WOA based on the remaining activity to determine the Direct Costs of the Project in the amount of \$400,000. SDG&E estimated Indirect Costs of the Project based on the estimate prepared for the WOA.

C. Actual Direct and Indirect Costs

Actual Direct Costs reflect the Labor, Material, and Services costs incurred to execute the Project. Actual Indirect Costs reflect costs for incremental overhead loaders in accordance with Company overhead allocation policies. The total loaded cost of the Project is \$2,379,002.

Final Report for Supply Line 49-28 Abandonment Project

Table 4: Estimated and Actual Direct Costs and Variances⁸

Direct Costs (\$)	Estimate	Actuals	Delta Over/(Under)
Company Labor	579	3,688	3,109
Materials	709	3,202	2,493
Construction Contractor	300,000	1,100,140	800,140
Construction Management & Support	32,503	173,209	140,706
Environmental	30,851	170,839	139,988
Engineering & Design	30,176	159,590	129,414
Project Management & Services	2,823	15,220	12,397
ROW & Permits	2,359	12,382	10,023
GMA	0	90,347	90,347
Total Direct Costs	400,000	1,728,618	1,328,618

Table 5: Estimated and Actual Indirect Costs, Total Costs, and Variances⁹

Indirect Costs/Total Costs (\$)	Estimate	Actuals	Delta Over/(Under)
Overheads	54,190	650,384	596,194
AFUDC	3,094	0	(3,094)
Property Taxes	0	0	0
Total Indirect Costs	57,284	650,384	593,100
Total Direct Costs	400,000	1,728,618	1,328,618
Total Loaded Costs	457,284	2,379,002	1,921,718

⁸ Values may not add to total due to rounding.

⁹ Ibid

Final Report for Supply Line 49-28 Abandonment Project

D. Disallowance

The scope of the Line 49-28 Abandonment Project did not include any pipe subject to disallowance under D.14-06-007 or D.15-12-020.

Final Report for Supply Line 49-28 Abandonment Project

V. CONCLUSION

SDG&E enhanced the safety of their integrated natural gas transmission system by prudently executing the Supply Line 49-28 Abandonment Project to complete the final phase of the Supply Line 49-28 Replacement Project. Through this Abandonment Project, SDG&E successfully grout filled three Caltrans crossings, and removed one MLV and one regulator station. The total loaded cost of the Project is \$2,379,002.

SDG&E executed this project prudently through meeting the strict permitting requirements set forth by Caltrans. SDG&E engaged in prudent cost avoidance efforts by utilizing SDG&E property for the laydown yard.

End of Supply Line 49-28 Abandonment Project Final Report

Final Report for Supply Line 49-11 Valve Enhancement Project

I. SUPPLY LINE 49-11 VALVE ENHANCEMENT PROJECT

A. Background and Summary

The Supply Line 49-11 Valve Enhancement Project consists of valve enhancements made to an existing mainline valve (MLV) located in the City of San Diego in San Diego County. Through this project, SDG&E enhanced the safety of its natural gas transmission system by enabling the rapid detection of a significant change in pipeline pressure and remote isolation and depressurization of a portion of Line 49-11 in the event of a pipeline rupture. SDG&E relocated an existing mainline valve, installed a new actuator, new power equipment, new communications equipment, and the necessary automation equipment. The total loaded project cost is \$2,145,312.

The Supply Line 49-11 Valve Enhancement Project construction site is located within an urban area in the central part of the City of San Diego. There are high voltage power lines nearby. The site is on SDG&E owned property.

WP-198 – 301

SDG&E Reasonableness Review

Valve Enhancement Project Workpapers

REASONABLENESS REVIEW VALVE ENHANCEMENT PROJECTS

Table 3 – Valve Project Bundles submitted in the 2024 Reasonableness Review

Valve Workpaper Title	Project Scope (valves, sites)	Workpaper Page
49-11 Valve Enhancement Project	1 Valve, 1 Site	WP-198
49-16 Valve Enhancement Bundle	4 Valves, 3 Sites	WP-213
49-18 Mission Valley Valve Enhancement Project	1 Valve, 1 Site	WP-238
49-23 Valve Enhancement Bundle	2 Valves, 2 Sites	WP-253
49-32 Valve Enhancement Project	1 Valve, 1 Site	WP-270
1601 Valve Enhancement Project	1 Valve, 1 Site	WP-287

Final Report for Supply Line 49-11 Valve Enhancement Project

Table 1: General Project Information

Supply Line 49-11 Valve Enhancement Project			
Location	San Diego		
Days on Site	34 days		
Construction Start	10/18/2016		
Construction Finish	05/04/2017		
Commissioning Date	12/12/2018		
Valve Upgrades			
Valve Number	2205		
Valve Type	Existing – Ball		
Actuator	New		
Actuator Above-/Below-Grade	Above-Grade		
ASV	Yes		
RCV	Yes		
Site Upgrades			
Vault	None		
Power	New – Solar		
Communication	New – Radio		
SCADA Panel	New		
Equipment Shelter	New		
Wall	New – Retaining		
Project Costs (\$)	Capital	O&M	Total
Loaded Project Costs	2,145,312	-	2,145,312
Disallowed Costs	-	-	-

Final Report for Supply Line 49-11 Valve Enhancement Project

B. Maps and Images

Figure 1: Satellite Image of Supply Line 49-11 Valve Enhancement Project



II. ENGINEERING, DESIGN, AND PLANNING

A. Project Scope

SoCalGas and SDG&E presented a conceptual project scope for the Supply Line 49-11 Valve Enhancement Project in workpapers supporting the Valve Enhancement Plan in the 2011 PSEP filing.¹ This conceptual scope identified MLV 2205 on Supply Line 49-11 for automation to enable remote isolation to a portion of Supply Line 49-11. Prior to initiating execution of the Project, SoCalGas and SDG&E reviewed available information and performed a detailed system flow analysis to validate the scope of the Project and confirmed that this valve enhancement will provide the planned isolation. The final project scope is summarized in Table 2 below.

1. 2011 PSEP Filing: SDG&E identified MLV 2205 on Supply Line 49-11 for automation to achieve the objective of rapid system isolation.
2. Updated Scope: Upon project initiation, SDG&E reviewed the conceptual project scope and determined that this isolation point would achieve the transmission isolation objectives set forth in the Valve Enhancement Plan.
3. Engineering, Design, and Constructability: The valve selected for automation was orientated on its side with a gearbox attached to the existing valve. The Project Team determined that, due to the depth of the pipeline, and to facilitate the installation of the new actuator, the valve required repositioning so that the valve stem protrudes straight up from the top of the valve.
4. Final Project Scope: The final project scope consists of the automation of one valve that included the repositioning of an existing MLV, the installation of a new actuator, the installation of power equipment, the installation of communications equipment, and the installation of necessary automation equipment at the project site.

¹ See Amended PSEP of SoCalGas and SDG&E, submitted December 2, 2011, in R.11-02-019 and subsequently transferred to A.11-11-002.

Final Report for Supply Line 49-11 Valve Enhancement Project

Table 2: Final Project Scope

Final Project Scope				
Line	Valve #	Valve Size (<i>confidential</i>)	Installation Type	Function
49-11	2205		A/AG	ASV/RCV

B. Site Evaluation and Planning

SDG&E initiated the planning process for the Supply Line 49-11 Valve Enhancement Project by performing a pre-design site walk to determine the existing conditions and assess any potential impact on the design. Key factors that influenced the engineering and design of this project are as follows:

1. Site Description: This site is in an urban area within the central part of the City of San Diego. The land parcel is partially developed with the undeveloped portion consisting of mostly sloped terrain with predominantly native vegetation. There are high voltage power lines near the site.
2. Land Issues: The site is on land owned by SDG&E. The Project Team did not anticipate any land issues for this project.
3. DOT Class: This project site is in a Class 3 location.
4. Power Source: There was no preexisting power equipment. The Project Team installed new power equipment at the site.
5. Communication Technology: There was no preexisting communications equipment. The Project Team installed new communications equipment at the site.

C. Engineering, Design, and Planning Factors

SDG&E reviewed drawings and records, contacted internal planning groups, communicated with external stakeholders, conducted survey activity, performed potholing of the area to identify the presence of underground utilities and substructures, and

Final Report for Supply Line 49-11 Valve Enhancement Project

completed a site walk. Key factors that influenced the engineering and design of the Project are as follows:

1. Engineering Assessment: During the site evaluation, the Project Team confirmed the existing technology. The Project Team determined that the existing valve required repositioning and thus the line would be shut-in for a portion of construction.
2. Valve Details: The existing valve was a manually operated Class 300 ball valve, which was reused by the Project Team.
3. Actuator Details: There was no preexisting actuator. The Project Team installed a new actuator.
4. Customer Impact: The Project Team did not identify any anticipated service disruptions to customers. The Project Team utilized existing valves to shut-in the line and maintained service to customers by utilizing alternate feeds.
5. Community Impact: The Project Team did not anticipate any notable impacts to the community from this project.
6. Substructures: The Project Team did not identify any existing substructures that affected the design and engineering at this site.
7. Environmental: The Project Team did not identify any notable environmental concerns at the work site. An environmental monitor performed routine site visits during construction.
8. Permit Restrictions: There were no special permits or permit restrictions for this project site.
9. Land Use: The Project Team performed all work within existing SDG&E property.
10. Traffic Control: The Project Team did not identify any traffic control needs at the site.

Final Report for Supply Line 49-11 Valve Enhancement Project

Figure 2: Supply Line 49-11 Valve Enhancement Project Schematic

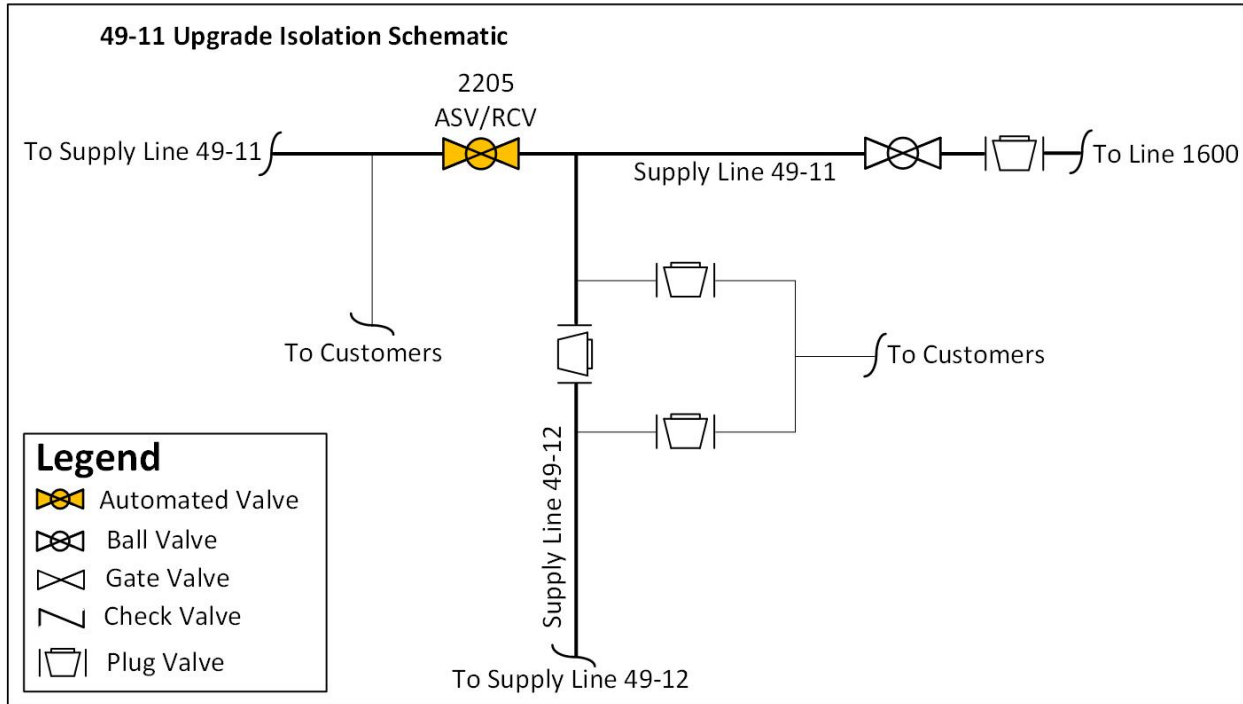

Final Report for Supply Line 49-11 Valve Enhancement Project

D. Scope Changes

Through engineering, design, and planning activities, SDG&E determined that changes in scope were appropriate to enhance the design of the Project and address engineering factors. As a result, the preliminary cost estimate does not fully reflect the final scope. Summarized below are notable changes in scope made after the preliminary cost estimate was developed and approved. After the development and approval of the preliminary cost estimate, The Project Team determined that utilizing utility power was not feasible due to the location of the nearest utility power source. The Project Team updated the design to include solar power. Additionally, the Project Team identified the need to install a retaining wall to protect the new automation equipment.

III. CONSTRUCTION

A. Construction Contractor Selection

The Project Team prepared an initial cost estimate based on the preliminary design. Following completion of the engineering, design, and planning activities described above, the Project Team directed the Performance Partner (Mechanical Construction Contractor) and Alliance Partner (Electrical Contractor) to prepare cost estimates based on a more detailed engineering design package, which included the updated design described in the discussion of notable changes in scope above.

1. SDG&E’s Preliminary Mechanical Construction Contractor Estimate (confidential): SDG&E’s preliminary cost estimate for construction was [REDACTED].
2. Mechanical Construction Contractor’s Target Price Estimate (confidential): The Mechanical Construction Contractor’s cost estimate was [REDACTED], which was [REDACTED] than SDG&E’s preliminary cost estimate for construction.
3. SDG&E’s Preliminary Electrical Contractor Estimate (confidential): SDG&E’s preliminary cost estimate for electrical construction was [REDACTED].
4. Electrical Contractor’s Estimate (confidential): The Electrical Contractor’s estimate was [REDACTED], which was [REDACTED] than SDG&E’s preliminary cost estimate.

B. Construction Schedule

Table 3: Construction Timeline

Construction Start Date	10/18/2016
Construction Completion Date	05/04/2017
Days on Site	34 days
Commissioning Date	12/12/2018

The Project Team completed all construction activities as soon as practicable prior to commissioning. Finalization of commissioning activities is dependent on electrical utility connections, and system and/or resource availability.

Final Report for Supply Line 49-11 Valve Enhancement Project

C. Changes During Construction

SDG&E successfully mitigated field conditions during construction in a manner that minimized potential impacts on project scope, cost, and schedule. As a result, these conditions did not result in any notable change orders.

Final Report for Supply Line 49-11 Valve Enhancement Project

Figure 3: Mainline Valve Assembly With Instrument Piping



Final Report for Supply Line 49-11 Valve Enhancement Project

D. Commissioning and Site Restoration

Commissioning activities included site restoration, final inspections, and placement of the valve back into service. During this stage, SDG&E successfully performed site acceptance testing and conducted point-to-point verification with Gas Control personnel for the newly automated valve, and transferred ownership of the new equipment to Field Operations. Closeout activities included development of final drawings, the reconciliation package, and updates to company recordkeeping systems to reflect the completed scope of work. The site was fully commissioned on December 12, 2018, as summarized in Table 3.

IV. PROJECT COSTS

A. Cost Avoidance Actions

SDG&E exercised due diligence in the design, planning, and construction activities for this project to minimize or avoid costs when prudent to do so. As discussed above, the Project Team reviewed existing records, communicated with external stakeholders, and conducted a site walk to incorporate known site conditions in the project plan and design. The Project Team reused the existing valve as opposed to installing a new mainline valve.

B. Cost Estimates

Based on the preliminary design, once the preliminary project scope was confirmed and engineering, design, and planning activities were underway, SDG&E prepared an estimate of the Direct Costs of the Project in the amount of \$1,706,878. The Project Team considered the conditions known at the time to prepare the preliminary Direct Cost estimate. This estimate reflects the projected Labor, Material, and Services costs anticipated to be incurred to execute the Project, based on initial design plans.

SDG&E estimated Indirect Costs of the Project based on the estimated Direct Costs and other project-related variables.

C. Actual Direct and Indirect Costs

Actual Direct Costs reflect the Labor, Material, and Services costs incurred to execute the Project. Actual Indirect Costs reflect costs for incremental overhead loaders in accordance with Company overhead allocation policies. The total loaded cost of the Project is \$2,145,312.

Final Report for Supply Line 49-11 Valve Enhancement Project

Table 4: Estimated and Actual Direct Costs and Variances²

Direct Costs (\$)	Estimate	Actuals	Delta Over/(Under)
Company Labor	106,660	59,461	(47,199)
Materials	165,080	82,578	(82,502)
Mechanical Construction Contractor	429,342	337,881	(91,461)
Electrical Contractor	76,073	70,736	(5,337)
Construction Management & Support	126,873	190,248	63,375
Environmental	149,960	19,760	(130,201)
Engineering & Design	266,356	974,439	708,083
Project Management & Services	245,384	42,576	(202,808)
ROW & Permits	4,600	5,360	760
GMA	136,550	72,537	(64,013)
Total Direct Costs	1,706,878	1,855,575	148,697

Table 5: Estimated and Actual Indirect Costs, Total Costs, and Variances³

Indirect Costs/Total Costs (\$)	Estimate	Actuals	Delta Over/(Under)
Overheads	234,667	175,927	(58,740)
AFUDC	206,991	99,492	(107,499)
Property Taxes	0	14,317	14,317
Total Indirect Costs	441,658	289,737	(151,921)
Total Direct Costs	1,706,878	1,855,575	148,697
Total Loaded Costs	2,148,536	2,145,312	(3,224)

² Values may not add to total due to rounding.

³ Ibid

V. CONCLUSION

SDG&E enhanced the safety of their integrated natural gas system by prudently executing the Supply Line 49-11 Valve Enhancement Project. Through this Valve Enhancement Project, SDG&E successfully automated one valve to achieve the objective of enabling rapid system isolation of a portion of Supply Line 49-11 within the City of San Diego. The total loaded cost of the Project is \$2,145,312.

SDG&E executed this project prudently through designing and executing the Project to support achievement of Valve Enhancement Plan isolation objectives, responding to unanticipated changes by modifying the design from utility power to solar power, and by installing the equipment necessary to bring power and communications to this valve to enable rapid automated isolation to a portion of Line 49-11 in San Diego County.

SDG&E engaged in prudent cost avoidance efforts to complete this safety enhancement at a reasonable cost by engaging in reasonable efforts to promote competitive and market-based rates for contractor services and materials and using a reasonable amount of Company and contractor resources to complete this safety enhancement as soon as practicable.

End of Supply Line 49-11 Valve Enhancement Project Final Report

Final Report for Supply Line 49-16 Valve Enhancement Bundle

I. SUPPLY LINE 49-16 VALVE ENHANCEMENT BUNDLE

A. Background and Summary

The Supply Line 49-16 Valve Enhancement Bundle consists of valve enhancements made to four mainline valves¹ (MLVs) located in the Cities of La Mesa, National City, and Lemon Grove in San Diego County. Through this project, SDG&E enhanced the safety of its natural gas transmission system by enabling the rapid detection of a significant change in pipeline pressure and remote isolation and depressurization of portions of Lines 49-16, 49-16E, and 49-18 in the event of a pipeline rupture. The Project Team coordinated the execution of this Valve Enhancement Bundle with the PSEP project Supply Line 49-16 Replacement and Hydrotest Project that included the installation of three new valves. The Valve Enhancement Bundle scope included the installation of four new actuators, new power equipment, new communications equipment, and the necessary automation equipment at the sites. The total loaded project cost is \$2,290,560.

The valves comprising the Supply Line 49-16 Valve Enhancement Bundle are separated into four construction sites that are in urban areas. The La Mesa Gate Station site is within an existing SDG&E facility in the City of La Mesa in an area that is a mix of residential and commercial developments. Workspace at the site was constrained due to the existing gas pressure regulator station, a sloped bank, and other infrastructure surrounding the work location. Furthermore, an elevated electrified light rail track crosses above the work location, limiting the use of cranes and tall equipment. The available work area was relatively small, with the perimeter closely bound by a water drainage channel, Interstate 8, and related freeway on ramps and city surface streets. The 4th and Palm site that is within an existing SDG&E facility at the

¹ Three of the valves automated in this project, valves 30217, 30317, and 32516, were in the project scope for the PSEP Supply Line 49-16 Replacement Project. The costs associated with the MLV installations are discussed in the associated pipeline replacement workpaper also submitted as part of this filing.

Final Report for Supply Line 49-16 Valve Enhancement Bundle

intersection of 4th Street and Palm Avenue in the City of National City in an area that is a mix of residential and commercial developments. There are overhead electrical utility lines next to the site. The Massachusetts and Main site is located at the intersection of Main Street and Massachusetts Avenue in the City of Lemon Grove in an area that is a mix of residential and commercial developments. There are two sets of railroad tracks across the street from the Project site. SDG&E grouped the three project sites together into a single valve bundle and executed the three sites as a comprehensive package because the sites are geographically proximate.

Final Report for Supply Line 49-16 Valve Enhancement Bundle

Table 1: General Project Information

Supply Line 49-16 Enhancement Bundle			
Site	La Mesa Gate Station	4th & Palm	Massachusetts & Main
Location	City of La Mesa	City of National City	City of Lemon Grove
Days on Site	16 days	44 days	10 days
Construction Start	09/20/2017	02/06/2018	09/11/2017
Construction Finish	11/02/2017	10/01/2018	11/03/2017
Commissioning Date	08/29/2018	12/12/2018	12/11/2018
Valve Upgrades			
Valve Number	1602L-9180B-S	30217	32516
Valve Type	Existing – Ball	New ² – Ball	New ³ – Ball
Actuator	New	New	New
Actuator Above-/Below-Grade	Above-Grade	Above-Grade	Below-Grade
ASV	Yes	Yes	Yes
RCV	Yes	Yes	Yes
Valve Number		30317	
Valve Type		New ⁴ – Ball	
Actuator		New	
Actuator Above-/Below-Grade		Above-Grade	
ASV		Yes	
RCV		Yes	
Site Upgrades			
Vault	None	None	New
Power	Existing – Utility	New – Utility	New – Utility
Communication	Existing – Radio	New – Radio	New – Radio
SCADA Panel	New	New	New
Equipment Shelter	None	None	None
Fencing	Existing – Fencing	Existing – Fencing	None
Project Costs (\$)	Capital	O&M	Total
Loaded Project Costs	2,290,560	-	2,290,560
Disallowed Costs	-	-	-

² The cost of the installation of the new valve was incurred by the PSEP Supply Line 49-16 Replacement Project

³ Ibid

⁴ Ibid

Final Report for Supply Line 49-16 Valve Enhancement Bundle

B. Maps and Images

Figure 1: Satellite Image of Supply Line 49-16 Valve Enhancement Bundle Overview

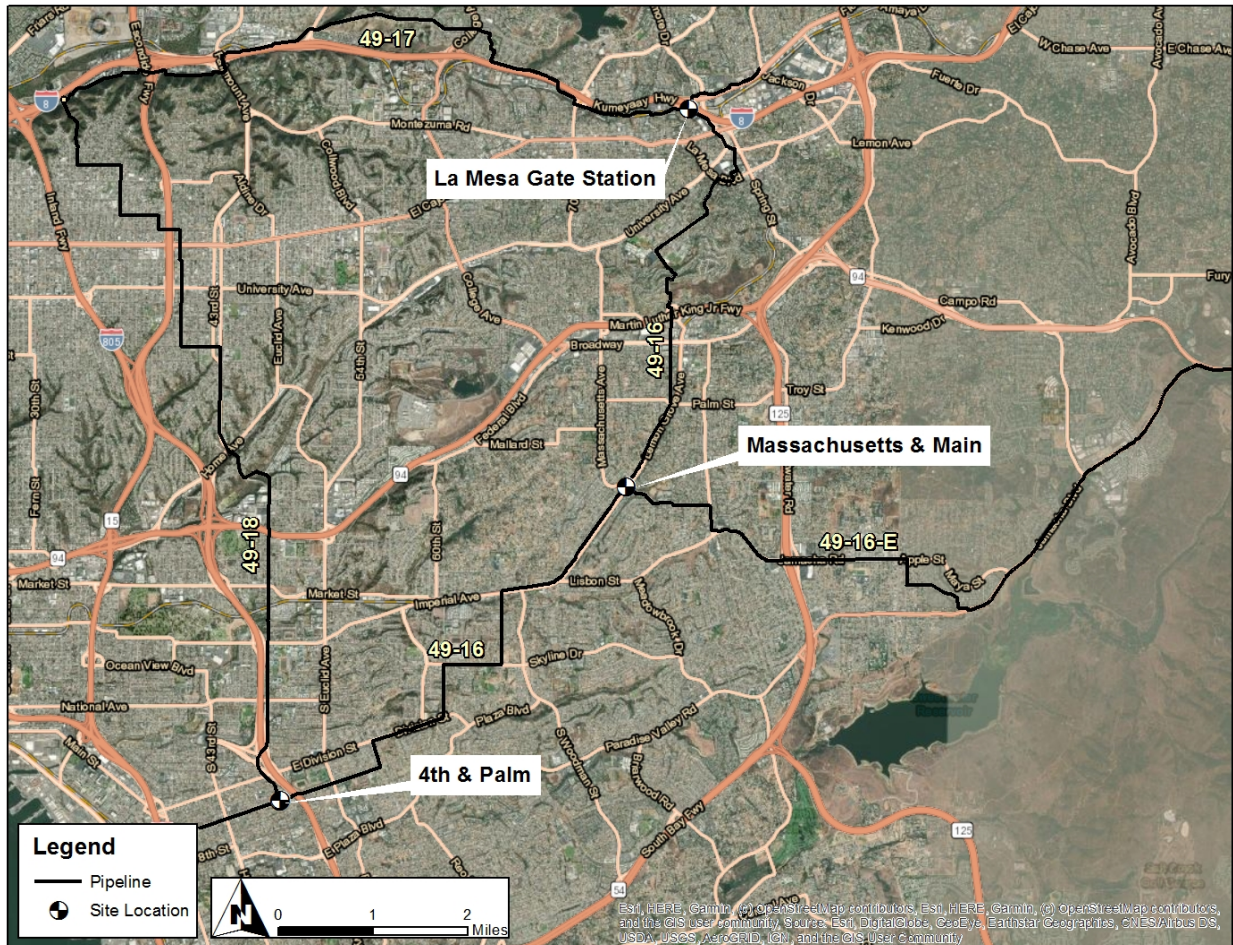

Final Report for Supply Line 49-16 Valve Enhancement Bundle

Figure 2: Satellite Image of La Mesa Gate Station Site

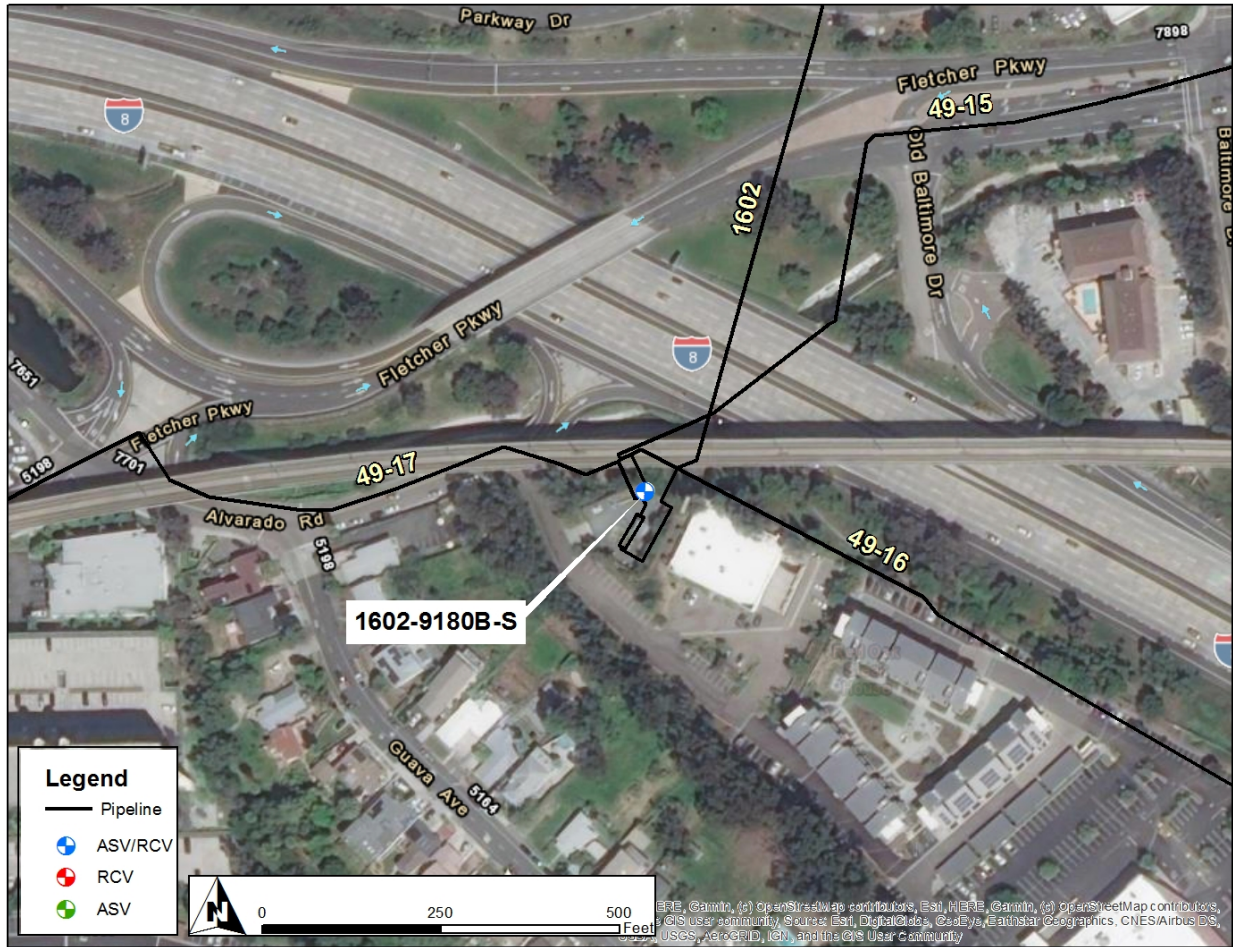

Final Report for Supply Line 49-16 Valve Enhancement Bundle

Figure 3: Satellite Image of 4th and Palm Site



II. ENGINEERING, DESIGN, AND PLANNING

A. Project Scope

SoCalGas and SDG&E presented a conceptual project scope in workpapers supporting the Valve Enhancement Plan⁵ in the 2011 PSEP filing. This conceptual scope identified six MLV's for automation to enable remote isolation to a portion of Lines 49-16, 49-18, and 49-21. Prior to initiating execution of the Project, SDG&E reviewed available information, performed a detailed system flow analysis to validate the scope of the Project and determined that a revised scope would better achieve project objectives. The revised scope included the installation and enhancement of three new valves and the automation of an existing valve, that would be sufficient to provide the planned rapid isolation. The final project scope is summarized in Table 2 below.

1. 2011 PSEP Filing: SoCalGas and SDG&E identified MLVs 49-16-832, 49-16-1040, 46-16-1041, 49-18-830, 49-21-1330, and 49-21-1331 for automation to achieve the objective of rapid system isolation. This scope was later updated.
2. Updated Scope: Upon project initiation, SDG&E reviewed the conceptual project scope and determined that the installation and automation of three new valves on Lines 49-16, 49-16E, and 49-18, and the automation of an existing valve on Line 49-16 would better achieve the objectives set forth in the Valve Enhancement Plan. The Project Team updated the scope to exclude the automation of MLVs 49-16-832, 49-18-830, 49-21-1330, and 49-21-1331.
3. Engineering, Design, and Constructability:
 - a. La Mesa Gate Station: No notable engineering adjustments were required to the standard design.
 - b. 4th and Palm: The Project Team coordinated the enhancement of the valves at this site with the Supply Line 49-16 Replacement and Hydrotest Project. The installation of the two new valves identified for automation was included in the

⁵ See Amended PSEP of SoCalGas and SDG&E, submitted December 2, 2011, in R.11-02-019 and subsequently transferred to A.11-11-002.

Final Report for Supply Line 49-16 Valve Enhancement Bundle

scope of the Supply Line 49-16 Replacement and Hydrotest Project. The scope of the automation work for this valve which is part of the 49-16 Valve Enhancement Bundle included the installation of power, communication equipment, and the necessary automation equipment. No notable engineering adjustments were required to the standard design.

- c. Massachusetts and Main: The Project Team coordinated the enhancement of the valve at this site with the Supply Line 49-16 Section 4 Replacement and Hydrotest Project. The installation of the new valve identified for automation was included in the scope of the Supply Line 49-16 Section 4 Replacement and Hydrotest Project. The scope of the automation work for this valve which is part of the 49-16 Valve Enhancement Bundle included the installation of power, communication equipment, and the necessary automation equipment. No notable engineering adjustments were required to the standard design.
- 4. Final Project Scope: The final project scope for the Supply Line 49-16 Valve Enhancement Bundle consists of the installation of four new actuators, the installation of a new vault to house one actuator, the installation of power equipment, the installation of communications equipment, and the installation of the necessary automation equipment at the project sites.

Table 2: Final Project Scope

Final Project Scope					
Site	Line	Valve #	Valve Size (<i>confidential</i>)	Installation Type	Function
La Mesa Gate	49-16	1602L-9180B-S	████████	A/AG	ASV/RCV
4 th and Palm	49-16	30217	████████	NV/AG	ASV/RCV
	49-18	30317	████████	NV/AG	ASV/RCV
Mass. & Main	49-16E	32516	████████	NV/VT	ASV/RCV

Final Report for Supply Line 49-16 Valve Enhancement Bundle

B. Site Evaluation and Planning

SDG&E initiated the planning process for the Supply Line 49-16 Valve Enhancement Bundle by performing a pre-design site walk to determine the existing conditions and assess any potential impact on the design. Key factors that influenced the engineering and design of this project are as follows:

La Mesa Gate Station

1. Site Description: The site is an existing SDG&E facility located in an area that is a mixture of commercial and residential buildings. Workspace at the site was constrained due to the existing gas pressure regulator station, a sloped bank and other infrastructure surrounding the work location. Furthermore, an elevated electrified light rail track crosses above the work location, limiting the use of cranes and tall equipment. The available work area was relatively small, with the perimeter closely bound by a water drainage channel, Interstate 8, and related freeway on ramps and city surface streets.
2. Land Issues: During the pre-design site walk, the Project Team noted that the existing facility can accommodate the new equipment.
3. DOT Class: This project site is in a Class 3 location.
4. Power Source: The site had existing utility power.
5. Communication Technology: The site had existing radio communications.

4th and Palm

1. Site Description: The site is located in an SDG&E facility in a high-density area that is a mix of commercial and residential buildings. There are overhead electrical utility lines next to the site.
2. Land Issues: During the pre-design site walk, the Project Team determined that the new equipment should be enclosed in a fence to increase public safety.

Final Report for Supply Line 49-16 Valve Enhancement Bundle

3. Schedule Coordination: The Project Team coordinated the construction at this site with the PSEP project Supply Line 49-16 Section 1 Replacement Project⁶. The scope of the replacement project included the installation of two new valves.
4. DOT Class: This project site is in a Class 3 location.
5. Power Source: There was no preexisting power equipment. The Project Team installed new power equipment.
6. Communication Technology: There was no preexisting communications equipment. The Project Team installed new communications equipment at the site.

Massachusetts and Main

1. Site Description: This site is in a high-density area that is a mix of commercial and residential buildings. There are two sets of railroad tracks adjacent to the Project site.
2. Land Issues: During the pre-design site walk, the Project Team noted that the new actuator will need to be below grade in a vault to protect the new equipment and increase public safety. The Project Team also noted that excavations will impact the street as well as the adjacent sidewalk.
3. DOT Class: This project site is in a Class 3 location.
4. Power Source: There was no preexisting electrical power source. The Project Team installed new power equipment.
5. Communication Technology: There was no preexisting communications equipment. The Project Team installed new communications equipment at the site.

C. Engineering, Design, and Planning Factors

SDG&E reviewed drawings and records, contacted internal planning groups, communicated with external stakeholders, conducted survey activity, performed

⁶ The final report for Supply Line 49-16 Section 1-7 Replacement and Hydrotest Projects is included in these workpapers and includes a description of the activities and costs associated with the installation of Valves 30217 and 30317.

Final Report for Supply Line 49-16 Valve Enhancement Bundle

potholing of the area to identify the presence of underground utilities and substructures, and completed a site walk. Key factors that influenced the engineering and design of the Project are as follows:

La Mesa Gate Station

1. Engineering Assessment: During the site evaluation, the Project Team confirmed the existing equipment and technology and verified that the station could accommodate the new valve enhancement related equipment.
2. Valve Details: The existing valve was a manually operated Class 600 ball valve, which was reused by the Project Team.
3. Actuator Details: There was no preexisting actuator. The Project Team installed a new actuator.
4. Customer Impact: The Project Team did not identify any anticipated service disruptions to customers.
5. Community Impact: The Project Team did not anticipate any notable impacts to the community from this project.
6. Substructures: The Project Team did not identify any existing substructures that affected the design and engineering at this site.
7. Environmental: The Project Team did not identify any notable environmental concerns at the site. An environmental monitor performed routine site visits during construction.
8. Permit Restrictions: There were no special permits or permit restrictions for this project site.
9. Land Use: The Project Team performed all work within the existing SDG&E facility.
10. Traffic Control: The Project Team did not identify any traffic control needs at the site.

Final Report for Supply Line 49-16 Valve Enhancement Bundle

4th and Palm

1. Engineering Assessment: During the site evaluation, the Project Team confirmed the existing equipment and technology and verified that the station could accommodate the new valve enhancement related equipment.
2. Valve Details:
 - a. MLV 30217: The existing valve was a manually operated Class 600 ball valve, which was reused by the Project Team.
 - b. MLV 30317: The existing valve was a manually operated Class 300 ball valve, which was reused by the Project Team.
3. Actuator Details:
 - a. MLV 30217: There was no preexisting actuator. The Project Team installed a new actuator.
 - b. MLV 30317: There was no preexisting actuator. The Project Team installed a new actuator.
4. Customer Impact: The Project Team did not anticipate service disruptions to customers.
5. Community Impact: The Project Team restricted public access to the sidewalk during construction.
6. Substructures: The Project Team did not identify any existing substructures that affected the design and engineering at this site.
7. Environmental: The Project Team did not identify any notable environmental concerns at the site. An environmental monitor performed routine site visits during construction.
8. Permit Restrictions: Other than traffic control related requirements, there were no special permits or permit restrictions for this project site.
9. Land Use: The Project Team performed all work within the SDG&E facility.
10. Traffic Control: The Project Team closed two lanes on Palm Avenue during construction.

Final Report for Supply Line 49-16 Valve Enhancement Bundle

Massachusetts and Main

1. Engineering Assessment: During the site evaluation, the Project Team confirmed the existing technology and verified the need to install the new actuator in a new vault below grade.
2. Valve Details: The existing valve was a manually operated Class 600 ball valve, which was reused by the Project Team.
3. Actuator Details: There was no preexisting actuator. The Project Team installed a new actuator.
4. Customer Impact: The Project Team did not anticipate service disruptions to customers
5. Community Impact: The Project Team restricted public access to the sidewalk during construction.
6. Substructures: The Project Team did not identify any existing substructures that affected the design and engineering at this site.
7. Environmental: The Project Team did not identify any notable environmental concerns at the site. An environmental monitor performed routine site visits during construction.
8. Permit Restrictions: The Project Team obtained encroachment permits from the City of Lemon Grove and the San Diego Metropolitan Transit System. The Project Team also obtained Traffic Control Plans from The San Diego Metropolitan Transit System and the City of San Diego.
9. Land Use: The Project Team utilized the laydown yard for the PSEP Supply Line 49-16 Sections 1-7 Replacement and Hydrotest Projects.
10. Traffic Control: The Project Team created a Traffic Control Plan to minimize the impact to the community. The Project Team closed two lanes on Main Street during construction.

Final Report for Supply Line 49-16 Valve Enhancement Bundle

Figure 5: Supply Line 49-16 Valve Enhancement Bundle – La Mesa Gate Station Schematic

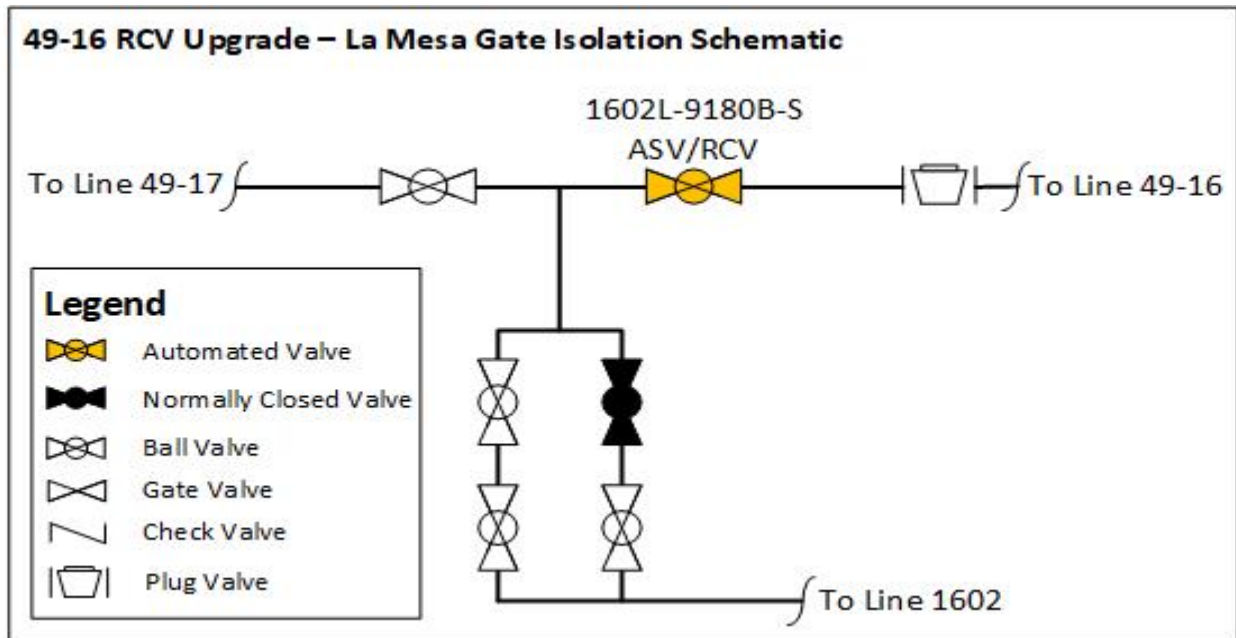

Final Report for Supply Line 49-16 Valve Enhancement Bundle

Figure 6: Supply Line 49-16 Valve Enhancement Bundle – 4th and Palm Schematic

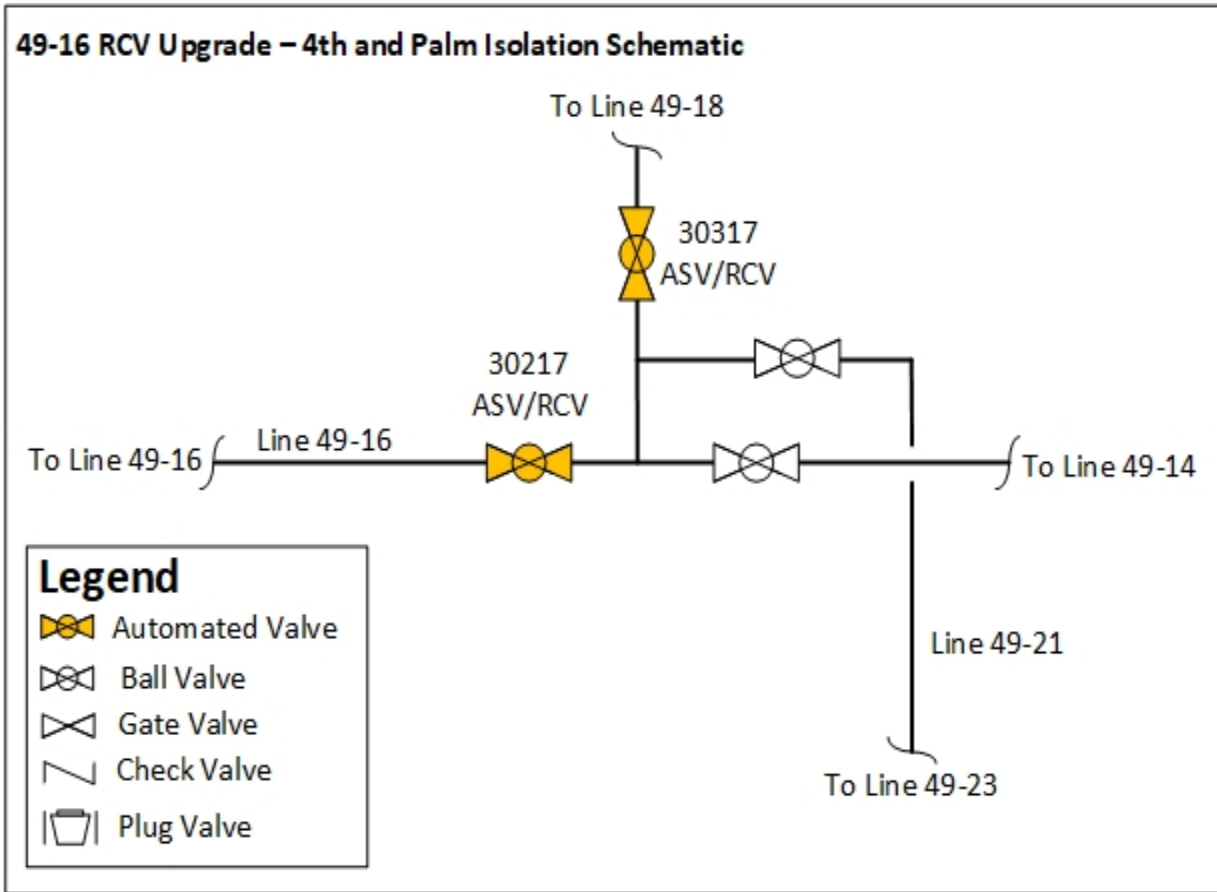

Final Report for Supply Line 49-16 Valve Enhancement Bundle

Figure 7: Supply Line 49-16 Valve Enhancement Bundle – Massachusetts and Main Schematic

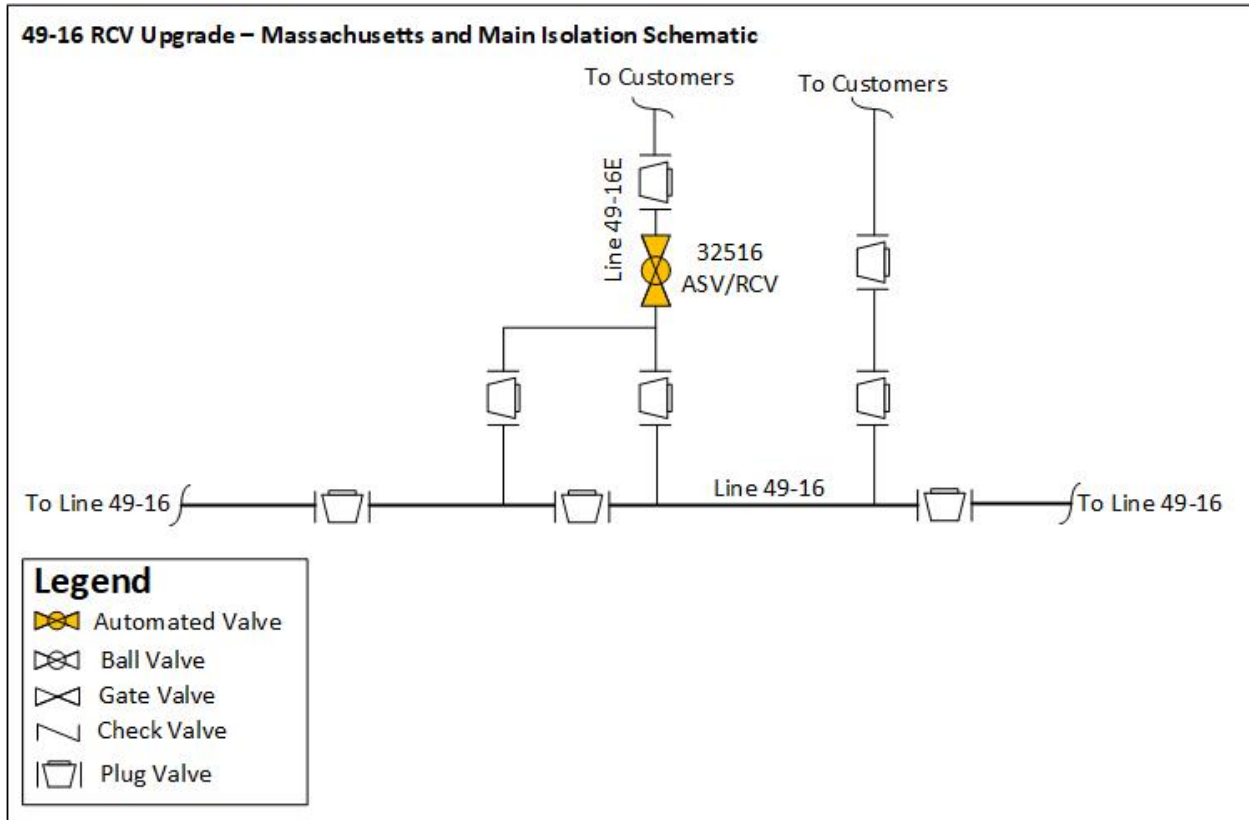

Final Report for Supply Line 49-16 Valve Enhancement Bundle

D. Scope Changes

SDG&E did not make any notable scope changes during detailed design.

III. CONSTRUCTION

A. Construction Contractor Selection

The Project Team prepared an initial cost estimate based on the preliminary design. Following completion of the engineering, design, and planning activities described above, the Project Team directed the Performance Partner (Mechanical Construction Contractor) and Alliance Partner (Electrical Contractor) to prepare cost estimates based on a more detailed engineering design package. As indicated above, there were no notable changes in scope between the time when the Project Team prepared the preliminary cost estimate and when the Performance Partner and Alliance Partner prepared and submitted their estimates.

1. SDG&E's Preliminary Mechanical Construction Contractor Estimate (confidential): SDG&E's preliminary cost estimate for construction was [REDACTED].
2. Mechanical Construction Contractor's Target Price Estimate (confidential): The Mechanical Construction Contractor's cost estimate was [REDACTED], which was [REDACTED] than SDG&E's preliminary cost estimate for construction.
3. SDG&E's Preliminary Electrical Contractor Estimate (confidential): SDG&E's preliminary cost estimate for construction was [REDACTED].
4. Electrical Contractor's Estimate (confidential): The Electrical Contractor's estimate was [REDACTED], which was [REDACTED] than SDG&E's preliminary cost estimate.

Final Report for Supply Line 49-16 Valve Enhancement Bundle

B. Construction Schedule

Table 3: Construction Timeline

La Mesa Gate	
Construction Start Date	09/20/2017
Construction Completion Date	11/02/2017
Days on Site	16 days
Commissioning Date	08/29/2018
4th and Palm	
Construction Start Date	02/06/2018
Construction Completion Date	10/01/2018
Days on Site	44 days
Commissioning Date	12/12/2018
Massachusetts and Main	
Construction Start Date	09/11/2017
Construction Completion Date	11/03/2017
Days on Site	10 days
Commissioning Date	12/11/2018

The Project Team completed all construction activities as soon as practicable prior to commissioning. Finalization of commissioning activities is dependent on electrical utility and communications connections, and system and/or resource availability. SDG&E upgraded the communication network while this project was in execution. This delayed the final commissioning of the valves automated in this bundle.

C. Changes During Construction

SDG&E successfully mitigated field conditions during construction in a manner that minimized potential impacts on project scope, cost, and schedule. As a result, these conditions did not result in any notable change orders.

Final Report for Supply Line 49-16 Valve Enhancement Bundle

Figure 8: Trenching Work for Electrical Power Supply Installation at the Massachusetts and Main Site



Final Report for Supply Line 49-16 Valve Enhancement Bundle

D. Commissioning and Site Restoration

Commissioning activities included site restoration, final inspections, and placement of the valves into service. During this stage, SDG&E successfully performed site acceptance testing, conducted point-to-point verification with SoCalGas Gas Control personnel for the newly automated valve, and transferred ownership of the new equipment to Field Operations. Closeout activities included development of final drawings, the reconciliation package, and updates to company recordkeeping systems to reflect the completed scope of work. The sites were commissioned on August 29, 2018, December 11, 2018, and December 12, 2018, as summarized in Table 3.

IV. PROJECT COSTS

A. Cost Avoidance Actions

SDG&E exercised due diligence in the design, planning, and construction activities for this project to minimize or avoid costs when prudent to do so. As discussed above, the Project Team reviewed existing records, communicated with external stakeholders, and conducted a site walk to incorporate known site conditions in the project plan and design. The Project Team shared the laydown yard with the PSEP Supply Line 49-16 Replacement and Hydrotest Projects avoiding the cost of getting an additional laydown yard.

B. Cost Estimates

Based on the preliminary design, once the preliminary project scope was confirmed and engineering, design, and planning activities were underway, SDG&E prepared an estimate of the Direct Costs of the Project in the amount of \$4,770,885. The Project Team considered the conditions known at the time to prepare the preliminary Direct Cost estimate. This estimate reflects the projected Labor, Material, and Services costs anticipated to be incurred to execute the Project, based on initial design plans.

SDG&E estimated Indirect Costs of the Project based on the estimated Direct Costs and other project-related variables.

C. Actual Direct and Indirect Costs

Actual Direct Costs reflect the Labor, Material, and Services costs incurred to execute the Project. Actual Indirect Costs reflect costs for incremental overhead loaders in accordance with Company overhead allocation policies. The total loaded cost of the Project is \$2,290,560.

Final Report for Supply Line 49-16 Valve Enhancement Bundle

Table 4: Estimated and Actual Direct Costs and Variances⁷

Direct Costs (\$)	Estimate	Actuals	Delta Over/(Under)
Company Labor	641,904	49,272	(592,632)
Materials	277,994	263,753	(14,241)
Mechanical Construction Contractor	849,055	441,716	(407,339)
Electrical Contractor	433,005	287,550	(145,455)
Construction Management & Support	211,915	54,367	(157,548)
Environmental	173,428	92,381	(81,047)
Engineering & Design	826,898	703,194	(123,704)
Project Management & Services	578,476	120,888	(457,588)
ROW & Permits	229,348	2,130	(227,218)
GMA	548,862	26,080	(522,782)
Total Direct Costs	4,770,885	2,041,331	(2,729,554)

Table 5: Estimated and Actual Indirect Costs, Total Costs, and Variances⁸

Indirect Costs/Total Costs (\$)	Estimate	Actuals	Delta Over/(Under)
Overheads	577,729	119,785	(457,944)
AFUDC	571,648	109,506	(462,142)
Property Taxes	0	19,938	19,938
Total Indirect Costs	1,149,377	249,229	(900,148)
Total Direct Costs	4,770,885	2,041,331	(2,729,554)
Total Loaded Costs	5,920,262	2,290,560	(3,629,702)

⁷ Values may not add to total due to rounding.

⁸ Ibid

Final Report for Supply Line 49-16 Valve Enhancement Bundle

V. CONCLUSION

SDG&E enhanced the safety of its natural gas system by prudently executing the Supply Line 49-16 Valve Enhancement Bundle. Through this Valve Enhancement Bundle, SDG&E successfully automated four valves to achieve the objective of enabling rapid system isolation of portions of Supply Lines 49-16, 49-16E, and 49-18 in the Cities of La Mesa, National City, and Lemon Grove. The total loaded cost of the Project is \$2,290,560.

SDG&E executed this project prudently through designing and executing the Project to support achievement of Valve Enhancement Plan isolation objectives, bundling three geographically proximate projects together to capture efficiencies through coordinated engineering, and by installing the equipment necessary to enable rapid system isolation to portions of Lines 49-16, 49-16E, and 49-18 in the Cities of La Mesa, National City, and Lemon Grove.

SDG&E engaged in prudent cost avoidance efforts to complete this safety enhancement at a reasonable cost by carefully planning and coordinating engineering and construction activities to maximize efficiencies and reduce customer and community impacts, engaging in reasonable efforts to promote competitive and market based rates for contractor services and materials, and using a reasonable amount of company and contractor resources to complete this safety enhancement as soon as practicable.

End of Supply Line 49-16 Valve Enhancement Bundle Final Report

I. SUPPLY LINE 49-18 MISSION VALLEY VALVE ENHANCEMENT PROJECT

A. Background and Summary

The Supply Line 49-18 Mission Valley Valve Enhancement Project consists of valve enhancements made to an existing valve located in the City of San Diego. Through this project, SDG&E enhanced the safety of its integrated natural gas transmission system by enabling the rapid detection of a significant change in pipeline pressure and remote isolation and depressurization of a portion of Supply Line 49-18 in the event of a pipeline rupture. SDG&E installed a new actuator, new power equipment, new communications equipment, and the necessary automation equipment at the site. The total loaded project cost is \$866,774.

The Supply Line 49-18 Mission Valley Enhancement Project construction site is within an existing SDG&E facility in the City of San Diego on Camino del Rio South just south of Interstate 8. There are several commercial buildings and a parking lot nearby.

Final Report for Supply Line 49-18 Mission Valley Valve Enhancement Project

Table 1: General Project Information

Supply Line 49-18 Mission Valley Valve Enhancement Project			
Location	San Diego		
Days on Site	9 days		
Construction Start	10/09/2017		
Construction Finish	11/14/2017		
Commissioning Date	02/26/2019		
Valve Upgrades			
Valve Number	2726		
Valve Type	Existing – Ball		
Actuator	New		
Actuator Above-/Below-Grade	Above-Grade		
ASV	Yes		
RCV	Yes		
Site Upgrades			
Vault	None		
Power	New – Solar		
Communication	New – Radio		
SCADA Panel	New		
Equipment Shelter	None		
Fencing	Existing		
Project Costs (\$)	Capital	O&M	Total
Loaded Project Costs	866,774	-	866,774
Disallowed Costs	-	-	-

Final Report for Supply Line 49-18 Mission Valley Valve Enhancement Project

B. Maps and Images

Figure 1: Satellite Image of Supply Line 49-18 Mission Valley Valve Enhancement Project



II. ENGINEERING, DESIGN, AND PLANNING

A. Project Scope

SDG&E presented a conceptual project scope for the 49-18 Mission Valley Header RCV Upgrade Valve Enhancement Project in workpapers supporting the Valve Enhancement Plan in the 2011 PSEP filing.¹ This conceptual scope identified a valve on Line 49-18 at the Mission Valley Header for automation to provide remote isolation to a portion of Line 49-18. SDG&E reviewed available information, performed a detailed system flow analysis, and confirmed that this valve enhancement will provide the planned isolation. The final project scope is summarized in Table 2 below.

1. 2011 PSEP Filing: SDG&E identified a valve at this site for automation to achieve the objective of rapid system isolation.
2. Updated Scope: Upon project initiation, SDG&E reviewed the conceptual project scope and determined that this isolation point would achieve the transmission isolation objectives set forth in the Valve Enhancement Plan.
3. Engineering, Design, and Constructability: No notable engineering adjustments were required to the standard design.
4. Final Project Scope: The final project scope consists of the automation of one valve that included the installation of a new actuator, the installation of new power equipment, the installation of new communications equipment, and the installation of the necessary automation equipment at the project sites.

¹ See Workpapers supporting Amended Pipeline Safety Enhancement Plan (PSEP) of SoCalGas and SDG&E, submitted on December 2, 2011, at WP-IX-2-14 through WP-IX-2-25 (A.11-11-002 Exh. # SCG-32).

Final Report for Supply Line 49-18 Mission Valley Valve Enhancement Project

Table 2: Final Project Scope

Final Project Scope					
Line	Mile ²	Valve #	Valve Size (<i>confidential</i>)	Installation Type	Function
49-18	N/A	2726	██████████	A/AG	ASV/RCV

B. Site Evaluation and Planning

SDG&E initiated the planning process for the Supply Line 49-18 Mission Valley Valve Enhancement Project by performing a pre-design site walk to determine the existing conditions and assess any potential impact on the design. Key factors that influenced the engineering and design of this project are as follows:

1. Site Description: The site is an existing SDG&E facility in a commercial area in the City of San Diego.
2. Land Issues: During the pre-design site walk, the Project Team noted that the existing facility can accommodate the new equipment.
3. DOT Class: This project site is in a Class 3 location.
4. Power Source: There was no preexisting power source at the valve site. The Project Team installed new power equipment at the site.
5. Communication Technology: There was no preexisting communications equipment at the valve site. The Project Team installed new communications equipment at the site.

C. Engineering, Design, and Planning Factors

SDG&E reviewed drawings and records, contacted internal planning groups, communicated with external stakeholders, conducted survey activity, performed potholing of the area to identify the presence of underground utilities and substructures,

² Valve naming convention at SDG&E does not include mile point.

Final Report for Supply Line 49-18 Mission Valley Valve Enhancement Project

and completed a site walk. Key factors that influenced the engineering and design of the Project are as follows:

1. Engineering Assessment: During the site evaluation, the Project Team confirmed the existing technology and verified that the station could accommodate the new equipment.
2. Valve Details: The existing valve was a manually operated Class 300 ball valve, which was reused by the Project Team.
3. Actuator Details: There was no preexisting actuator. The Project Team installed a new actuator.
4. Customer Impact: The Project Team did not identify any anticipated service disruptions to customers.
5. Community Impact: The project site is near the driveway to a local commercial property. Care was taken during construction to minimize the impact on the employees' day to day business.
6. Substructures: The Project Team did not identify any existing substructures that affected the design and engineering at this site.
7. Environmental: The Project Team did not identify any notable environmental concerns at the site. An environmental monitor performed routine site visits during construction.
8. Permit Restrictions: There were no special permits or permit restrictions for this project site.
9. Land Use: The Project Team performed all work within the existing SDG&E facility. The Project Team obtained a Temporary Right of Entry (TPE) with the nearby property to use the parking lot adjacent to the worksite during construction.
10. Traffic Control: The Project Team did not identify any traffic control needs at the site.

Final Report for Supply Line 49-18 Mission Valley Valve Enhancement Project

Figure 2: Line 49-18 Mission Valley Header RCV Upgrade Valve Enhancement Project Schematic

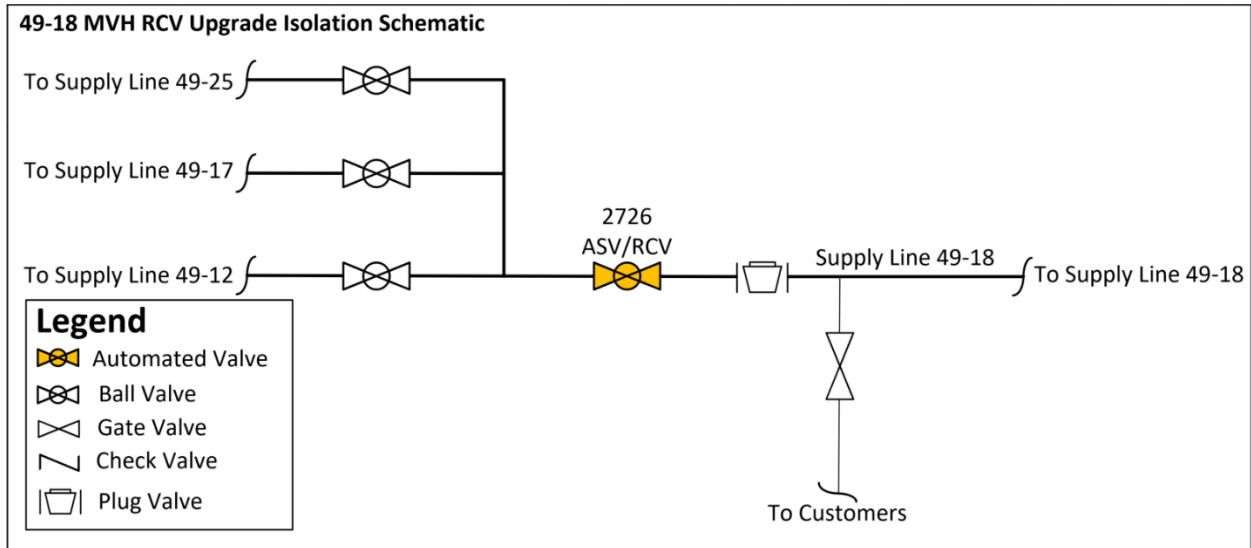

Final Report for Supply Line 49-18 Mission Valley Valve Enhancement Project

D. Scope Changes

Through engineering, design, and planning activities, SDG&E determined that changes in scope were appropriate to enhance the design of the Project and address engineering factors. As a result, the preliminary cost estimate does not fully reflect the final scope. The Project Team initially planned to utilize utility power. The Project Team altered the design to incorporate the installation of solar power due to delays encountered in obtaining utility power.

III. CONSTRUCTION

A. Construction Contractor Selection

The Project Team prepared an initial cost estimate based on the preliminary design. Following completion of the engineering, design, and planning activities described above, the Project Team directed the Performance Partner (Mechanical Construction Contractor) and Alliance Partner (Electrical Contractor) to prepare cost estimates based on a more detailed engineering design package, which included the updated design described in the discussion of notable changes in scope above.

1. SDG&E’s Preliminary Mechanical Construction Contractor Estimate (confidential): SDG&E’s preliminary cost estimate for construction was [REDACTED].
2. Mechanical Construction Contractor’s Target Price Estimate (confidential): The Mechanical Construction Contractor’s cost estimate was [REDACTED], which was [REDACTED] than SDG&E’s preliminary cost estimate for construction.
3. SDG&E’s Preliminary Electrical Contractor Estimate (confidential): SDG&E’s preliminary cost estimate for construction was [REDACTED].
4. Electrical Contractor’s Estimate (confidential): The Electrical Contractor’s estimate was [REDACTED], which was [REDACTED] than SDG&E’s preliminary cost estimate.

B. Construction Schedule

Table 3: Construction Timeline

Construction Start Date	10/09/2017
Construction Completion Date	11/14/2017
Days on Site	9 days
Commissioning Date	2/26/2019

The Project Team completed all construction activities as soon as practicable prior to commissioning. Finalization of commissioning activities is dependent on electrical utility connections, and system and/or resource availability.

Final Report for Supply Line 49-18 Mission Valley Valve Enhancement Project

C. Changes During Construction

SDG&E successfully mitigated field conditions during construction in a manner that minimized potential impacts on project scope, cost, and schedule. As a result, these conditions did not result in any notable change orders.

Final Report for Supply Line 49-18 Mission Valley Valve Enhancement Project

Figure 3: New Instrumentation Taps



Final Report for Supply Line 49-18 Mission Valley Valve Enhancement Project

D. Commissioning and Site Restoration

Commissioning activities included site restoration, final inspections, and placement of the valve into service. During this stage, SDG&E successfully performed site acceptance testing and conducted point-to-point verification with Gas Control personnel for the newly automated valve and transferred ownership of the new equipment to Field Operations. Closeout activities included development of final drawings, the reconciliation package, and updates to company recordkeeping systems to reflect the completed scope of work. The site was commissioned on February 26, 2019, as summarized in Table 3.

IV. PROJECT COSTS

A. Cost Avoidance Actions

SDG&E exercised due diligence in the design, planning, and construction activities for this project to minimize or avoid costs when prudent to do so. As discussed above, the Project Team reviewed existing records, communicated with external stakeholders, and conducted a site walk to incorporate known site conditions in the project plan and design. Automating a valve in an existing SDG&E facility avoided costs compared to other potential locations that would have required acquiring additional land rights.

B. Cost Estimates

Based on the preliminary design, once the preliminary project scope was confirmed and engineering, design, and planning activities were underway, SDG&E prepared an estimate of the Direct Costs of the Project in the amount of \$1,176,283. The Project Team considered the conditions known at the time to prepare the preliminary Direct Cost estimate. This estimate reflects the projected Labor, Material, and Services costs anticipated to be incurred to execute the Project, based on initial design plans.

SDG&E estimated Indirect Costs of the Project based on the estimated Direct Costs and other project-related variables.

C. Actual Direct and Indirect Costs

Actual Direct Costs reflect the Labor, Material, and Services costs incurred to execute the Project. Actual Indirect Costs reflect costs for incremental overhead loaders in accordance with Company overhead allocation policies. The total loaded cost of the Project is \$866,774.

Final Report for Supply Line 49-18 Mission Valley Valve Enhancement Project

Table 4: Estimated and Actual Direct Costs and Variances³

Direct Costs (\$)	Estimate	Actuals	Delta Over/(Under)
Company Labor	152,527	23,354	(129,173)
Materials	109,620	77,775	(31,845)
Mechanical Construction Contractor	204,460	68,364	(136,096)
Electrical Contractor	100,650	118,124	17,474
Construction Management & Support	65,420	76,139	10,719
Environmental	40,337	40,574	237
Engineering & Design	176,113	232,798	56,685
Project Management & Services	118,727	8,207	(110,520)
ROW & Permits	73,105	5,000	(68,105)
GMA	135,324	30,116	(105,208)
Total Direct Costs	1,176,283	680,450	(495,833)

Table 5: Estimated and Actual Indirect Costs, Total Costs, and Variances⁴

Indirect Costs/Total Costs (\$)	Estimate	Actuals	Delta Over/(Under)
Overheads	229,292	183,995	(45,297)
AFUDC	62,782	2,164	(60,618)
Property Taxes	-	165	165
Total Indirect Costs	292,074	186,324	(105,750)
Total Direct Costs	1,176,283	680,450	(495,833)
Total Loaded Costs	1,468,357	866,774	(601,583)

³ Values may not add to total due to rounding.

⁴ Ibid.

Final Report for Supply Line 49-18 Mission Valley Valve Enhancement Project

V. CONCLUSION

SDG&E enhanced the safety of its natural gas system by prudently executing the Supply Line 49-18 Mission Valley Valve Enhancement Project. Through this Valve Enhancement Project, SDG&E successfully automated one valve to achieve the objective of enabling rapid system isolation of a portion of Line 49-18 in the City of San Diego. The total loaded cost of the Project is \$ 866,774.

SDG&E executed this project prudently through designing and executing the Project to support achievement of Valve Enhancement Plan isolation objectives, installing the equipment necessary to bring power and communication capabilities to this valve, and by installing the necessary automation equipment to enable rapid system isolation to a portion of Supply Line 49-18 located in the City of San Diego.

SDG&E engaged in prudent cost avoidance efforts to complete this safety enhancement project at a reasonable cost by carefully planning and coordinating construction activities to minimize the impact to the community, and by scheduling the tie-in to prevent service interruptions to customers limiting the number of mobilizations and reducing costs for customers.

End of Supply Line 49-18 Mission Valley Valve Enhancement Project Final Report

Final Report for Supply Line 49-23 Valve Enhancement Bundle

I. SUPPLY LINE 49-23 VALVE ENHANCEMENT BUNDLE

A. Background and Summary

The Supply Line 49-23 Valve Enhancement Bundle consists of valve enhancements made to one new mainline valve (MLV) and the installation of one new check valve in the City of Chula Vista. Through this project, SDG&E enhanced the safety of its natural gas transmission system by enabling the rapid detection of a significant change in pipeline pressure and remote isolation and depressurization of a portion of Supply Lines 49-24 and 49-24-D in the event of a pipeline rupture. SDG&E installed one new MLV, one new check valve, a new bridle assembly, one new actuator, two new vaults, new power equipment, new communications equipment, and the necessary automation equipment at the sites. The total loaded project cost is \$2,642,662.

The Supply Line 49-23 Valve Enhancement Bundle construction sites are located in high density residential areas at two separate sites. The 5th and J site is located on J Street west of the intersection of 5th Avenue and J Street and is surrounded by single family homes. The 5th and L site is located on 5th Avenue south of the intersection of 5th Avenue and L Street next to a church and a high school. SDG&E grouped the two project sites into a single valve bundle and executed the two sites as a comprehensive package because the sites are geographically proximate and are in locations where work could be performed simultaneously.

Final Report for Supply Line 49-23 Valve Enhancement Bundle

Table 1: General Project Information

Supply Line 49-23 Valve Enhancement Bundle			
Site	5th and J	5th and L	
Location	City of Chula Vista	City of Chula Vista	
Days on Site	77 days	77 days	
Construction Start	09/10/2018	09/10/2018	
Construction Finish	02/22/2019	02/22/2019	
Commissioning Date	11/19/2018 ¹	07/16/2019	
Valve Upgrades			
Valve Number	N/A	30018	
Valve Type	New – Check ²	New – Ball	
Actuator	N/A	New	
Actuator Above-/Below-Grade	N/A	Below-Grade	
ASV	N/A	Yes	
RCV	N/A	Yes	
Site Upgrades			
Vault	New	New	
Power	None	New – Utility	
Communication	None	New – Radio	
SCADA Panel	None	New	
Equipment Shelter	None	None	
Fencing/Wall	None	None	
Project Costs (\$)	Capital	O&M	Total
Loaded Project Costs	2,642,662	-	2,642,662
Disallowed Costs	-	-	-

¹ This date represents the NOP date of the valve.

² Check valves are not numbered.

Final Report for Supply Line 49-23 Valve Enhancement Bundle

B. Maps and Images

Figure 1: Satellite Image of Supply Line 49-23 Valve Enhancement Bundle



II. ENGINEERING, DESIGN, AND PLANNING

A. Project Scope

SoCalGas and SDG&E presented a conceptual project scope for the Supply Line 49-23 Valve Enhancement Bundle in workpapers supporting the Valve Enhancement Plan in the 2011 PSEP filing.³ This conceptual scope identified MLV 884 for automation to enable remote isolation to a portion Supply Line 49-23. Prior to initiating execution of the Project, SDG&E reviewed available information and performed a detailed system flow analysis and determined that the installation and automation of a new mainline valve on Supply Line 49-24 and the installation of a new check valve on Supply Line 49-24-D as they would better achieve the isolation objectives compared to MLV 884 on Supply Line 49-23. The final project scope is summarized in Table 2 below.

1. 2011 PSEP Filing: SDG&E identified MLV 884 for automation to achieve the objective of rapid system isolation.
2. Updated Scope: Upon project initiation, SDG&E reviewed the conceptual project scope and determined that the installation and automation of a new valve on Supply Line 49-23 and the installation of a new check valve on Supply Line 49-24-D would better achieve the objectives set forth in the Valve Enhancement Plan. The Project Team updated the scope to reflect the revised plan which then excluded the automation of MLV 49-23-884.
3. Engineering, Design, and Constructability:
 - a. 5th and J: SDG&E determined that the installation of a bridle assembly around the new check valve installation would provide enhanced operational flexibility and

³ See Amended PSEP of SoCalGas and SDG&E, submitted December 2, 2011, in R.11-02-019 and subsequently transferred to A.11-11-002.

Final Report for Supply Line 49-23 Valve Enhancement Bundle

would decrease future maintenance costs. The Project Team incorporated the installation of the assembly into the design.

- b. 5th and L: No notable engineering adjustments were required to the standard design.
- 4. Final Project Scope: The final project scope consists of: the installation of one new MLV, the installation of a new check valve, the installation of a new bridle assembly, the installation of a new actuator, the installation of two new vaults, the installation of power equipment, the installation of communications equipment, and the installation of the necessary automation equipment at the site.

Table 2: Final Project Scope

Final Project Scope					
Line	Mile ⁴	Valve #	Valve Size (<i>confidential</i>)	Installation Type	Function
49-24-D	N/A	N/A	[REDACTED]	NV	BFP2
49-24	N/A	30018	[REDACTED]	NV/VT	ASV/RCV

B. Site Evaluation and Planning

SDG&E initiated the planning process for the Supply Line 49-23 Valve Enhancement Bundle by performing a pre-design site walk to determine the existing conditions and assess any potential impact on the design. Key factors that influenced the engineering and design of this project are as follows:

5th and J (check valve with bridle)

1. Site Description: The site is located near the intersection of 5th Avenue and J Street in a high-density residential area.
2. Land Issues: During the pre-design site walk, the Project Team noted that excavations will impact the street as well as the adjacent sidewalk.
3. DOT Class: This project site is in a Class 3 location.

⁴ Valve naming convention at SDG&E does not include milepoint.

Final Report for Supply Line 49-23 Valve Enhancement Bundle

4. Power Source: The scope of work for this project site did not require any power equipment.
5. Communication Technology: The scope of work for this project site did not require any communications equipment.

5th and L (automated MLV)

1. Site Description: The site is located near the intersection of 5th Avenue and L Street and is located underneath 5th Avenue.
2. Land Issues: During the pre-design site walk, the Project Team noted that excavations will impact the street as well as the adjacent sidewalk.
3. DOT Class: This project site is in a Class 3 location.
4. Power Source: There was no preexisting power source. The Project Team installed new power equipment at the site.
5. Communication Technology: There was no preexisting communications equipment. The Project Team installed new communications equipment at the site.

C. Engineering, Design, and Planning Factors

SDG&E reviewed drawings and records, contacted internal planning groups, communicated with external stakeholders, conducted survey activity, performed potholing of the area to identify the presence of underground utilities and substructures, and completed a site walk. Key factors that influenced the engineering and design of the Project are as follows:

5th and J (check valve with bridle)

1. Engineering Assessment: The Project Team determined that the installation of a bridle assembly around the new check valve installation would provide enhanced operational flexibility and would decrease future maintenance costs. The Project Team incorporated the installation of the assembly into the design. The Project Team

Final Report for Supply Line 49-23 Valve Enhancement Bundle

also determined that the new check valve should be installed in a vault to improve access while performing maintenance.

2. Valve Details: There was no preexisting check valve. The Project Team installed a new check valve.
3. Actuator Details: The scope of work for this project site did not require an actuator.
4. Customer Impact: The Project Team utilized pressure control fittings (PCFs) to prevent service disruptions to customers.
5. Community Impact: For safety reasons, the Project Team restricted public access to the sidewalk, and implemented traffic control measures in the street, during construction.
6. Substructures: The Project Team did not identify any existing substructures that affected the design and engineering at this site.
7. Environmental: The Project Team did not identify any notable environmental concerns at the site. An environmental monitor performed routine site visits during construction.
8. Permit Restrictions: The Project Team acquired a traffic control permit, an encroachment permit, and a utility permit from the City of Chula Vista.
9. Land Use: The Project Team utilized the same laydown yard in Chula Vista for both project sites.
10. Traffic Control: The Project Team utilized signage, flagmen, channelization devices, and barricades to direct traffic during construction. The Project Team also closed the sidewalk on the west side of J Street.

5th and L

1. Engineering Assessment: The Project Team did not make any notable changes to the engineering and design of this project.
2. Valve Details: There was no preexisting valve. The Project Team installed a new Class 600 ball valve.
3. Actuator Details: There was no preexisting actuator. The Project Team installed a new actuator.

Final Report for Supply Line 49-23 Valve Enhancement Bundle

4. Customer Impact: The Project Team backfed existing customers during the tie-in and therefore was able to maintain service to customers without disruption.
5. Community Impact: For safety reasons, the Project Team restricted public access to the sidewalk, and implemented traffic control measures in the street, during construction.
6. Substructures: The Project Team did not identify any existing substructures that affected the design and engineering at this site.
7. Environmental: The Project Team did not identify any notable environmental concerns at the site. An environmental monitor performed routine site visits during construction.
8. Permit Restrictions: The Project Team acquired a traffic control permit, an encroachment permit, and a utility permit from the City of Chula Vista.
9. Land Use: The Project Team utilized the same laydown yard in Chula Vista for both project sites.
10. Traffic Control: The Project Team utilized signage, flagmen, channelization devices, and barricades to direct traffic during construction. The Project Team also closed the sidewalk on the west side of 5th Avenue.

Final Report for Supply Line 49-23 Valve Enhancement Bundle

Figure 2: Supply Line 49-23 Valve Enhancement Bundle Schematic

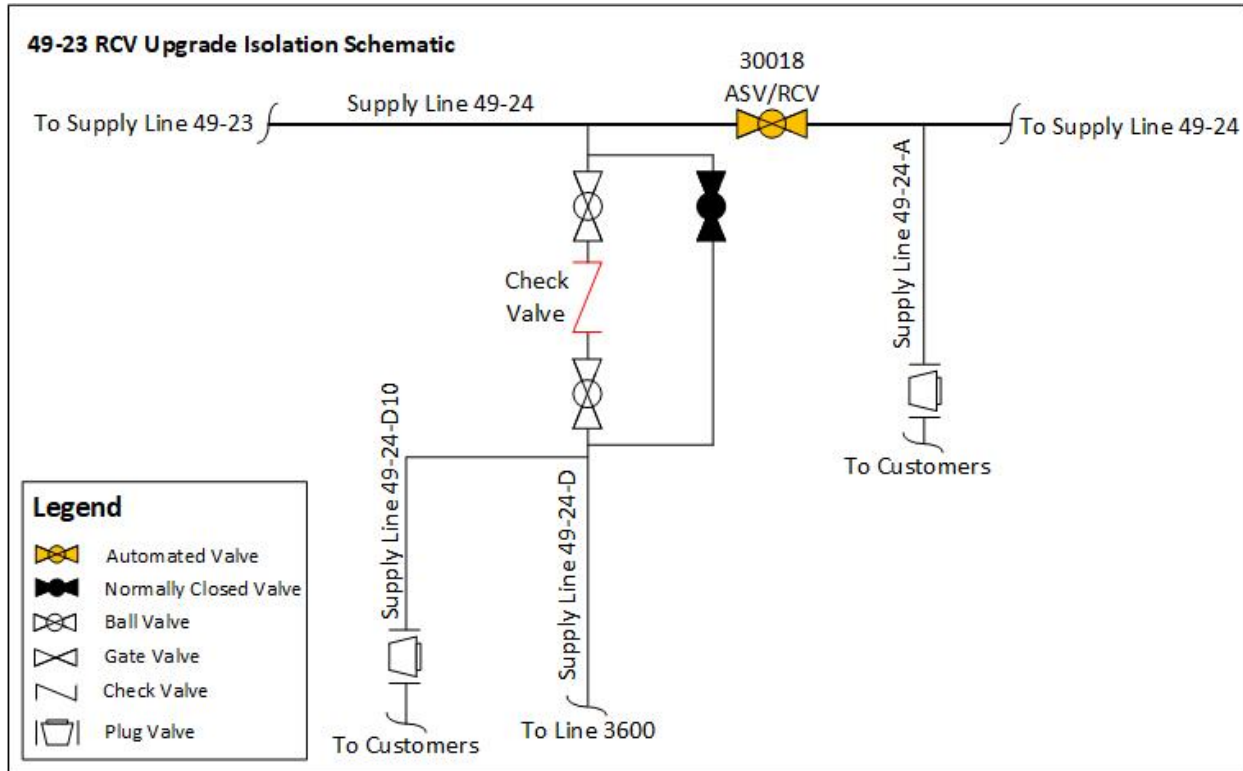

Final Report for Supply Line 49-23 Valve Enhancement Bundle

D. Scope Changes

SDG&E did not make any notable scope changes during detailed design.

III. CONSTRUCTION

A. Construction Contractor Selection

The Project Team prepared an initial cost estimate based on the preliminary design. Following completion of the engineering, design, and planning activities described above, the Project Team directed the Performance Partner (Mechanical Construction Contractor) and Alliance Partner (Electrical Contractor) to prepare cost estimates based on a more detailed engineering design package. As indicated above, there were no notable changes in scope between the time when the Project Team prepared the preliminary cost estimate and when the Performance Partner and Alliance Partner prepared and submitted their estimates.

1. SDG&E's Preliminary Mechanical Construction Contractor Estimate (confidential): SDG&E's preliminary cost estimate for construction was [REDACTED].
2. Mechanical Construction Contractor's Target Price Estimate (confidential): The Mechanical Construction Contractor's cost estimate was [REDACTED], which was [REDACTED] than SDG&E's preliminary cost estimate for construction.
3. SDG&E's Preliminary Electrical Contractor Estimate (confidential): SDG&E's preliminary cost estimate for construction was [REDACTED].
4. Electrical Contractor's Estimate (confidential): The Electrical Contractor's estimate was [REDACTED], which was [REDACTED] than SDG&E's preliminary cost estimate.

Final Report for Supply Line 49-23 Valve Enhancement Bundle

B. Construction Schedule

Table 3: Construction Timeline

5th and J	
Construction Start Date	09/10/2018
Construction Completion Date	02/22/2019
Days on Site	77 days
NOP Date	11/19/2018
5th and L	
Construction Start Date	09/10/2018
Construction Completion Date	02/22/2019
Days on Site	115 days
Commissioning Date	7/16/2019

The Project Team completed all construction activities as soon as practicable prior to commissioning. SDG&E’s finalization of commissioning activities was dependent on electrical utility and communication connections, and system and/or resource availability.

C. Changes During Construction

SDG&E successfully mitigated conditions during construction in a manner that minimized potential impacts on project scope, cost, and schedule. As a result, these conditions did not result in any notable change orders. SDG&E successfully completed construction in a manner that minimized potential impacts on project scope, cost, and schedule. As a result, there were no Construction Contractor change orders.

Final Report for Supply Line 49-23 Valve Enhancement Bundle

D. Commissioning and Site Restoration

Commissioning activities included site restoration, final inspections, and placement of the valves into service. During this stage, SDG&E successfully performed site acceptance testing, conducted point to point verification with Gas Control personnel for the newly automated valve, and transferred ownership of the new equipment to Field Operations. Closeout activities included development of final drawings, the reconciliation package, and updates to company recordkeeping systems to reflect the completed scope of work. The site was commissioned on July 16, 2019, as summarized in Table 3.

IV. PROJECT COSTS

A. Cost Avoidance Actions

SDG&E exercised due diligence in the design, planning, and construction activities for this project to minimize or avoid costs when prudent to do so. As discussed above, the Project Team reviewed existing records, communicated with external stakeholders, and conducted a site walk to incorporate the known site conditions in the project plan and design. Specific examples of cost avoidance actions taken on this project are:

1. Bundling of Projects: The Project Team grouped the two project sites into a single valve bundle and executed the two sites as a comprehensive package because the sites are geographically proximate and are in locations where work could be performed simultaneously.
2. Land Use: The Project Team utilized a laydown in Chula Vista for both project sites avoiding the costs of obtaining an additional temporary easement and setting up and maintaining a separate laydown yard.

B. Cost Estimates

Based on the preliminary design, once the preliminary project scope was confirmed and engineering, design, and planning activities were underway, SDG&E prepared an estimate of the Direct Costs of the Project in the amount of \$2,350,811. The Project Team considered the conditions known at the time to prepare the preliminary Direct Cost estimate. This estimate reflected the projected Labor, Material, and Services costs anticipated to be incurred to execute the Project, based on initial design plans.

SDG&E estimated Indirect Costs of the Project based on the estimated Direct Costs and other project-related variables.

Final Report for Supply Line 49-23 Valve Enhancement Bundle

C. Actual Direct and Indirect Costs

Actual Direct Costs reflect the Labor, Material, and Services costs incurred to execute the Project. Actual Indirect Costs reflect costs for incremental overhead loaders in accordance with Company overhead allocation policies. The total loaded cost of the Project is \$2,642,662.

Table 4: Estimated and Actual Direct Costs and Variances⁵

Direct Costs (\$)	Estimate	Actuals	Delta Over/(Under)
Company Labor	257,733	121,715	(136,018)
Materials	129,893	267,556	137,663
Mechanical Construction Contractor	692,481	771,343	78,862
Electrical Contractor	163,625	72,561	(91,064)
Construction Management & Support	89,292	318,259	228,967
Environmental	230,451	80,305	(150,146)
Engineering & Design	412,630	509,318	96,688
Project Management & Services	240,928	42,842	(198,086)
ROW & Permits	51,272	28,374	(22,898)
GMA	82,506	71,000	(11,506)
Total Direct Costs	2,350,811	2,283,273	(67,539)

Table 5: Estimated and Actual Indirect Costs, Total Costs, and Variances⁶

Indirect Costs/Total Costs (\$)	Estimate	Actuals	Delta Over/(Under)
Overheads	598,802	332,903	(265,898)
AFUDC	233,396	23,273	(210,123)
Property Taxes	0	3,214	3,214
Total Indirect Costs	832,197	359,389	(472,808)
Total Direct Costs	2,350,812	2,283,273	(67,539)
Total Loaded Costs	3,183,008	2,642,662	(540,347)

⁵ Values may not add to total due to rounding.

⁶ Ibid.

Final Report for Supply Line 49-23 Valve Enhancement Bundle

V. CONCLUSION

SDG&E enhanced the safety of its natural gas system by prudently executing the 49-23 Valve Enhancement Bundle. Through this Valve Enhancement Bundle, SDG&E successfully installed and automated one new MLV and installed one new check valve with bridle to achieve the objective of enabling rapid system isolation in the City of Chula Vista. The total loaded cost of the Project is \$2,642,662.

SDG&E executed this project prudently through designing and executing the project to support achievement of Valve Enhancement Plan isolation objectives, combining two geographically proximate sites together to capture efficiencies through coordinated engineering, and by installing the equipment necessary to enable rapid system isolation to portions of Supply Lines 49-24 and 49-24-D in the City of Chula Vista.

SDG&E engaged in prudent cost avoidance efforts to complete this safety enhancement at a reasonable cost by carefully planning and coordinating engineering and construction activities to maximize efficiencies and reduce customer and community impacts, engaging in reasonable efforts to promote competitive and market based rates for contractor services and materials, and using a reasonable amount of company and contractor resources to complete this safety enhancement as soon as practicable.

End of Supply Line 49-23 Valve Enhancement Bundle Final Report

Final Report for Supply Line 49-32 Valve Enhancement Project

I. SUPPLY LINE 49-32 VALVE ENHANCEMENT PROJECT

A. Background and Summary

The Line 49-32 Valve Enhancement Project consists of valve enhancements made to one mainline valve (MLV) located in the City of San Diego in San Diego County. Through this project, SDG&E enhanced the safety of its natural gas transmission system by enabling the rapid detection of a significant change in pipeline pressure and remote isolation and depressurization of a portion of Supply Line 49-32 in the event of a pipeline rupture. SDG&E installed one new actuator, new power equipment, new communications equipment, and the necessary automation equipment at the site. The total loaded project cost is \$2,497,474.

The Supply Line 49-32 Valve Enhancement Project construction site is located in a high-density commercial area next to the interchange for Interstate 5 and Interstate 8 on the heavily traveled Pacific Highway in the City of San Diego.

Final Report for Supply Line 49-32 Valve Enhancement Project

Table 1: General Project Information

Supply Line 49-32 Valve Enhancement Project			
Location	City of San Diego		
Days on Site	32 days		
Construction Start	10/17/2016		
Construction Finish	12/01/2016		
Commissioning Date	02/27/2019		
Valve Upgrades			
Valve Number	20400		
Valve Type	New ¹ – Ball		
Actuator	New		
Actuator Above-/Below-Grade	Below-Grade		
ASV	Yes		
RCV	Yes		
Site Upgrades			
Vault	New		
Power	New – Utility		
Communication	New – Radio		
SCADA Panel	New		
Equipment Shelter	None		
Fencing/Wall	None		
Project Costs (\$)	Capital	O&M	Total
Loaded Project Costs	2,497,474	-	2,497,474
Disallowed Costs	-	-	-

¹ The cost of the installation of the new valve was incurred by the PSEP Supply Line 49-32-L Replacement Project

Final Report for Supply Line 49-32 Valve Enhancement Project

B. Maps and Images

Figure 1: Satellite Image of Supply Line 49-32 Valve Enhancement Project



II. ENGINEERING, DESIGN, AND PLANNING

A. Project Scope

SoCalGas and SDG&E presented a conceptual project scope for the Supply Line 49-32 Valve Enhancement Project in workpapers supporting the Valve Enhancement Plan in the PSEP 2011 filing.² This conceptual scope identified MLV 806 on Supply Line 49-11 for automation to provide remote isolation to a portion of Supply Line 49-11. Prior to initiating execution of the Project, SDG&E reviewed available information and performed a detailed system flow analysis to validate the scope of the Project, and identified MLV 6495 on Supply Line 49-32 for enhancement to provide the planned isolation as it would better achieve the isolation objectives compared to MLV 806 on Supply Line 49-11. The final project scope is summarized in Table 2 below.

1. 2011 PSEP Filing: SDG&E identified MLV 806 on Supply Line 49-11 for automation to achieve the objective of rapid system isolation.
2. Updated Scope: Upon Valve Enhancement Project initiation, SDG&E reviewed the conceptual project scope and determined that this isolation point would not achieve the transmission isolation objectives set forth in the Valve Enhancement Plan. The Project Team determined that the automation of the MLV 6495 on Supply Line 49-32 would better achieve the objectives set forth in the Valve Enhancement Plan. MLV 6495 is now called MLV 20400.³
3. Engineering, Design, and Constructability: The Project Team coordinated the enhancement of the valve at this site with the Supply Line 49-32-L Replacement Project. The installation of the new valve identified for automation was included in the scope of the 49-32-L Replacement Project. The scope of the automation work for this

² See Workpapers supporting Amended Pipeline Safety Enhancement Plan (PSEP) of SoCalGas and SDG&E, submitted on December 2, 2011, at WP-IX-2-14 through WP-IX-2-25 (A.11-11-002 Exh. SCG-32).

³ MLV 6495 was relocated as part of the Supply Line 49-32-L Replacement Project and the MLV was accordingly renamed to reflect the new location.

Final Report for Supply Line 49-32 Valve Enhancement Project

valve included the installation of power, communication equipment, and the necessary automation equipment. No notable engineering adjustments were required to the standard design.

4. Final Project Scope: The final project scope of the Supply Line 49-32 Valve Enhancement Project consists of the automation of one MLV, the installation of a new actuator, the installation of power equipment, the installation of communications equipment, and the installation of the necessary automation equipment at the project site.

Table 2: Final Project Scope

Final Project Scope					
Line	Mile ⁴	Valve #	Valve Size (<i>confidential</i>)	Installation Type	Function
49-32	N/A	20400	████████	A/VT	ASV/RCV

B. Site Evaluation and Planning

SDG&E initiated the planning process for the Supply Line 49-32 Valve Enhancement Project by performing a pre-design site walk to determine the existing conditions and assess any potential impact on the design. Key factors that influenced the engineering and design of this project are as follows:

1. Site Description: This site is located in a high-density, commercial area next to the interchange for Interstate 5 and Interstate 8 on the heavily trafficked Pacific Highway in the City of San Diego. The valve is in a vault in the street.
2. Land Issues: The Project Team noted that excavation will impact the street and sidewalk.
3. DOT Class: This project site is in a Class 3 location.
4. Power Source: There was no preexisting power source. The Project Team installed new power equipment at the site.

⁴ Valve naming convention at SDG&E does not include milepoint.

Final Report for Supply Line 49-32 Valve Enhancement Project

5. Communication Technology: There was no preexisting communications equipment. The Project Team installed new communications equipment at the site.

C. Engineering, Design, and Planning Factors

SDG&E reviewed drawings and records, contacted internal planning groups, communicated with external stakeholders, conducted survey activity, performed potholing of the area to identify the presence of underground utilities and substructures, and completed a site walk. Key factors that influenced the engineering and design of the Project are as follows:

1. Engineering Assessment: The Project Team coordinated the enhancement of the valve at this site with the Supply Line 49-32-L Replacement Project. The installation of the new valve identified for automation was included in the scope of the 49-32-L Replacement Project. Project Team coordinated construction schedules and executed the automation work immediately after the new MLV 20400 was installed.
2. Valve Details: There was no preexisting valve. A new Class 600 ball valve was installed as part of the 49-32-L Replacement Project.
3. Actuator Details: There was no preexisting actuator. The Project Team installed a new actuator.
4. Customer Impact: The Project Team did not identify any anticipated service disruptions to customers.
5. Community Impact: For safety reasons, the Project Team restricted public access to the sidewalk during construction.
6. Substructures: The Project Team identified a water main and culvert between the valve and the location of the necessary automation equipment. The Project Team routed the instrument piping to avoid the water line and culvert.
7. Environmental: The Project Team identified two trees that interfered with the planned construction and received permission to remove and replace the two trees. The Project Team prepared a Storm Water Pollution Prevention Plan (SWPPP). An environmental monitor performed routine site visits during construction.

Final Report for Supply Line 49-32 Valve Enhancement Project

8. Permit Restrictions: The Project Team obtained encroachment permits from Caltrans and the City of San Diego as well as an environmental permit from the City of San Diego.
9. Land Use: The Project Team shared a laydown yard with the Supply Line 49-32-L Replacement Project – Section 1 and 3.
10. Traffic Control: The Project Team closed the northbound lanes and limited street parking during construction.

Final Report for Supply Line 49-32 Valve Enhancement Project

Figure 2: Supply Line 49-32 Valve Enhancement Project Schematic

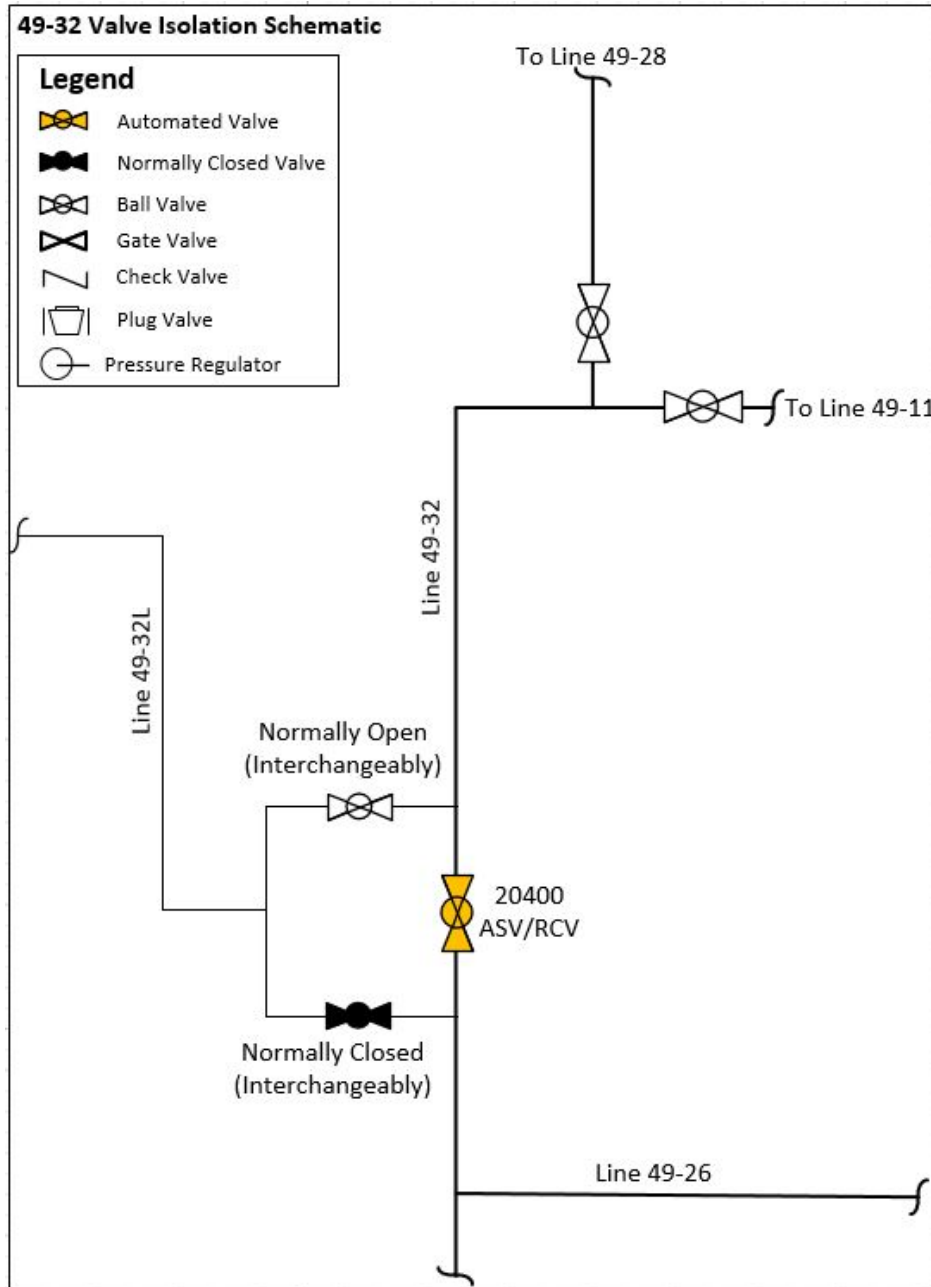

Final Report for Supply Line 49-32 Valve Enhancement Project

D. Scope Changes

Through engineering, design, and planning activities, SDG&E determined that changes in scope were appropriate to enhance the design of the Project and address engineering factors. As a result, the preliminary cost estimate does not fully reflect the final scope. Summarized below are notable changes in scope made after the preliminary cost estimate was developed and approved.

1. The Project Team initially planned to provide automation capabilities to the bridle valves around MLV 20400. Upon further engineering review, SDG&E determined that these valves did not require automation.
2. The Project Team also included in the preliminary estimate the cost of installing a new vault to house three actuators, as well as the related excavations. With the descoping of the automation of the two bridle valves, the vault and related excavations were significantly smaller. The installation of the vault was included in the Supply Line 49-32-L Replacement Project.

Final Report for Supply Line 49-32 Valve Enhancement Project

III. CONSTRUCTION

A. Construction Contractor Selection

The Project Team prepared an initial cost estimate based on the preliminary design. Following completion of the engineering, design, and planning activities described above, the Project Team directed the Performance Partner (Mechanical Construction Contractor) and Alliance Partner (Electrical Contractor) to prepare cost estimates based on a more detailed engineering design package, which included the updated design described in the discussion of notable changes in scope above.

1. SDG&E’s Preliminary Mechanical Construction Contractor Estimate (confidential): SDG&E’s preliminary cost estimate for construction was [REDACTED].
2. Mechanical Construction Contractor’s Target Price Estimate (confidential): The Mechanical Construction Contractor’s cost estimate was [REDACTED], which was [REDACTED] than SDG&E’s preliminary cost estimate for construction.
3. SDG&E’s Preliminary Electrical Contractor Estimate (confidential): SDG&E’s preliminary cost estimate for construction was [REDACTED].
4. Electrical Contractor’s Estimate (confidential): The Electrical Contractor’s estimate was [REDACTED], which was [REDACTED] than SDG&E’s preliminary cost estimate.

B. Construction Schedule

Table 3: Construction Timeline

Construction Start Date	10/17/2016
Construction Completion Date	12/01/2016
Days on Site	32 days
Commissioning Date	02/27/2019

The Project Team completed all construction activities as soon as practicable prior to commissioning. Finalization of commissioning activities was dependent on electrical utility and communication connections, and system and/or resource availability. SDG&E

Final Report for Supply Line 49-32 Valve Enhancement Project

upgraded the communication network while this project was in execution. This delayed the final commissioning of the valves automated in this bundle.

C. Changes During Construction

SDG&E successfully completed construction in a manner that minimized potential impacts on project scope, cost, and schedule. As a result, there were no Construction Contractor change orders.

Final Report for Supply Line 49-32 Valve Enhancement Project

Figure 3: New Vault Vent



Final Report for Supply Line 49-32 Valve Enhancement Project

Figure 4: New Sensing Lines



Final Report for Supply Line 49-32 Valve Enhancement Project

D. Commissioning and Site Restoration

Commissioning activities included site restoration, final inspections, and placement of the valve into service. During this stage, SDG&E successfully performed site acceptance testing, conducted point-to-point verification with Gas Control personnel for the newly automated valve, and transferred ownership of the new equipment to Field Operations. Closeout activities included development of final drawings, the reconciliation package, and updates to company recordkeeping systems to reflect the completed scope of work. The site was commissioned on February 27, 2019, as summarized in Table 3.

IV. PROJECT COSTS

A. Cost Avoidance Actions

SDG&E exercised due diligence in the design, planning, and construction activities for this project to minimize or avoid costs when prudent to do so. As discussed above, the Project Team reviewed existing records, communicated with external stakeholders, and conducted a site walk to incorporate known site conditions in the project plan and design. For this Project, the Project Team shared a laydown yard with the Supply Line 49-32-L Replacement Project, avoiding the cost of obtaining an additional temporary easement and setting up and maintaining a separate laydown yard.

B. Cost Estimates

Based on the preliminary design, once the preliminary project scope was confirmed and engineering, design, and planning activities were underway, SDG&E prepared an estimate of the Direct Costs of the Project in the amount of \$3,500,414. The Project Team considered the conditions known at the time to prepare the preliminary Direct Cost estimate. This estimate reflects the projected Labor, Material, and Services costs anticipated to be incurred to execute the Project, based on initial design plans.

SDG&E estimated Indirect Costs of the Project based on the estimated Direct Costs and other project-related variables.

C. Actual Direct and Indirect Costs

Actual Direct Costs reflect the Labor, Material, and Services costs incurred to execute the Project. Actual Indirect Costs reflect costs for incremental overhead loaders in accordance with Company overhead allocation policies. The total loaded cost of the Project is \$2,497,474.

Final Report for Supply Line 49-32 Valve Enhancement Project

Table 4: Estimated and Actual Direct Costs and Variances⁵

Direct Costs (\$)	Estimate	Actuals	Delta Over/(Under)
Company Labor	196,637	60,788	(135,849)
Materials	91,157	127,483	36,326
Mechanical Construction Contractor	1,781,503	122,969	(1,658,534)
Electrical Contractor	29,040	102,166	73,126
Construction Management & Support	115,633	50,383	(65,250)
Environmental	64,680	7,468	(57,212)
Engineering & Design	764,369	1,321,743	557,373
Project Management & Services	165,694	137,831	(27,863)
ROW & Permits	0	10,516	10,516
GMA	291,701	147,150	(144,551)
Total Direct Costs	3,500,414	2,088,498	(1,411,916)

Table 5: Estimated and Actual Indirect Costs, Total Costs, and Variances⁶

Indirect Costs/Total Costs (\$)	Estimate	Actuals	Delta Over/(Under)
Overheads	559,607	263,756	(295,851)
AFUDC	416,818	128,522	(288,296)
Property Taxes	0	16,699	16,699
Total Indirect Costs	976,425	408,977	(567,448)
Total Direct Costs	3,500,414	2,088,498	(1,411,916)
Total Loaded Costs	4,476,839	2,497,474	(1,979,365)

⁵ Values may not add to total due to rounding.

⁶ Ibid.

Final Report for Supply Line 49-32 Valve Enhancement Project

V. CONCLUSION

SDG&E enhanced the safety of its natural gas system by prudently executing the Supply Line 49-32 Valve Enhancement Project. Through this Valve Enhancement Project, SDG&E successfully installed and automated one mainline valve to achieve the objective of enabling rapid system isolation to a portion of Supply Line 49-32 in the City of San Diego. The total loaded cost of the Project is \$2,497,474.

SDG&E executed this project prudently through designing and executing the Project to support the Valve Enhancement Plan isolation objectives, installing a new actuator in the existing vault, and by installing the equipment necessary to bring power and communication capabilities to this valve to enable rapid system isolation to a portion of Supply Line 49-32 in the City of San Diego.

SDG&E engaged in prudent cost avoidance efforts to complete this safety enhancement at a reasonable cost by carefully planning and coordinating construction activities and coordinating with the Supply Line 49-32-L Replacement Project.

End of Supply Line 49-32 Valve Enhancement Project Final Report

I. LINE 1601 VALVE ENHANCEMENT PROJECT

A. Background and Summary

The Line 1601 Valve Enhancement Project consists of the installation of a flowmeter on Line 1601 located in the City of Carlsbad. Through this project, SDG&E enhanced the operational flexibility and the system diagnosis capabilities of its natural gas transmission system in the event of a significant change in pipeline pressure or the accidental closing of a valve on a portion of Line 1601. SDG&E installed a new flowmeter, a new vault to house the flowmeter, and new power equipment. The total loaded project cost is \$822,943.

The Line 1601 Valve Enhancement Project construction site is within an existing SDG&E facility located in a commercial area of the City of Carlsbad. The facility is located on a major thoroughfare, El Camino Real, north of the intersection of El Camino Real and Palomar Airport Road.

Final Report for Line 1601 Valve Enhancement Project

Table 1: General Project Information

Line 1601 Valve Enhancement Project			
Location	City of Carlsbad		
Days on Site	32 days		
Construction Start	04/23/2018		
Construction Finish	01/09/2019		
NOP Date	07/23/2019		
Valve Upgrades			
Valve Number	1601-0.0-FM		
Valve Type	Flowmeter		
Actuator	N/A		
Actuator Above-/Below-Grade	N/A		
ASV	No		
RCV	No		
Line 1601 Site Upgrades			
Vault	New		
Power	New – Utility		
Communication	Existing – Radio		
SCADA Panel	Existing		
Equipment Shelter	None		
Wall	Existing		
Project Costs (\$)	Capital	O&M	Total
Loaded Project Costs	822,943	-	822,943
Disallowed Costs	-	-	-

Final Report for Line 1601 Valve Enhancement Project

B. Maps and Images

Figure 1: Satellite Image of Line 1601 Valve Enhancement Project



II. ENGINEERING, DESIGN, AND PLANNING

A. Project Scope

SoCalGas and SDG&E presented a conceptual project scope for the Line 1601 Valve Enhancement Project in workpapers supporting the Valve Enhancement Plan in the 2011 PSEP filing.¹ Prior to initiating execution of the Project, SDG&E reviewed available information, performed a detailed system flow analysis, and identified this location as one of the candidates for a flowmeter installation. The final project scope is summarized in Table 2 below.

1. 2011 PSEP Filing: SoCalGas and SDG&E planned to install 20 flowmeters on its transmission system. This conceptual scope proposed to install 20 flowmeters on its transmission system at strategic locations to help identify leaks and system imbalances, to provide enhanced operational flexibility, and to assist with system diagnosis in the event of a rupture or accidental closing of a valve in an area with complex piping.²
2. Updated Scope: Upon project initiation, SDG&E reviewed the conceptual project scope and determined that this location is an ideal location for a flowmeter installation, achieving Valve Enhancement Plan objectives.
3. Engineering, Design, and Constructability: No notable engineering adjustments were required to the standard design.
4. Final Project Scope: The final project scope consists of the installation of a flowmeter, the installation of a new vault to house the flowmeter, and the installation of the necessary associated equipment such as new power connections.

¹ See Amended PSEP of SoCalGas and SDG&E, submitted December 2, 2011, in R.11-02-019 and subsequently transferred to A.11-11-002.

² See A.11-11-002, Chapter 9 Testimony and Workpapers of J.M. Rivera.

Final Report for Line 1601 Valve Enhancement Project

Table 2: Final Project Scope

Final Project Scope					
Line	Mile	Valve #	Valve Size (<i>confidential</i>)	Installation Type	Function
1601	0	FM		FM	FLOWMETER

B. Site Evaluation and Planning

SDG&E initiated the planning process for the Line 1601 Valve Enhancement Project by performing a pre-design site walk to determine the existing conditions and assess any potential impact on the design. Key factors that influenced the engineering and design of this project are as follows:

1. Site Description: This site is an existing SDG&E facility in an urban area. There is an existing wall enclosing the site.
2. Land Issues: During the pre-design site walk, the Project Team noted that the existing facility can accommodate the new equipment.
3. DOT Class: This project site is in a Class 3 location.
4. Power Source: There was existing solar power at the construction site. The Project Team installed new utility power to accommodate the new equipment.
5. Communication Technology: The site had existing radio communications.

C. Engineering, Design, and Planning Factors

SDG&E reviewed drawings and records, contacted internal planning groups, communicated with external stakeholders, conducted survey activity, performed potholing of the area to identify the presence of underground utilities and substructures, and completed a site walk. Key factors that influenced the engineering and design of the Project are as follows:

Final Report for Line 1601 Valve Enhancement Project

1. Engineering Assessment: During the site evaluation, the Project Team confirmed the preexisting technology and verified that the station could accommodate the new equipment.
2. Flowmeter Details: The Project Team installed a new, non-intrusive, ultrasonic flowmeter.
3. Customer Impact: The Project Team did not identify any anticipated service disruptions to customers.
4. Community Impact: The Project Team did not anticipate any notable impacts to the community from this project.
5. Substructures: The Project Team did not identify any existing substructures that affected the design and engineering at this site.
6. Environmental: The Project Team did not identify any notable environmental concerns at the work site. An environmental monitor performed routine site visits during construction.
7. Permit Restrictions: There were no special permits or permit restrictions for this project site.
8. Land Use: The Project Team performed all work within the existing SDG&E facility.
9. Traffic Control: The Project Team did not identify any traffic control needs at the site.

Final Report for Line 1601 Valve Enhancement Project

Figure 2: Line 1601 Valve Enhancement Project Schematic

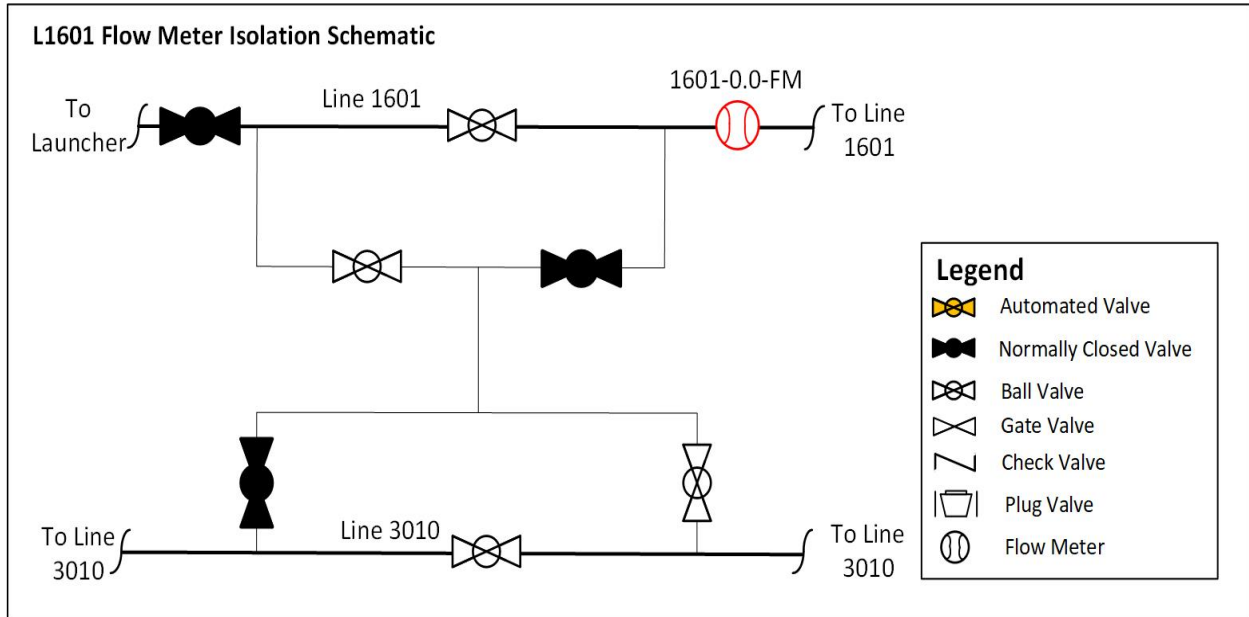

Final Report for Line 1601 Valve Enhancement Project

D. Scope Changes

SDG&E did not make any notable scope changes during detailed design.

III. CONSTRUCTION

A. Construction Contractor Selection

The Project Team prepared an initial cost estimate based on the preliminary design. Following completion of the engineering, design, and planning activities described above, the Project Team directed the Performance Partner (Mechanical Construction Contractor) and Alliance Partner (Electrical Contractor) to prepare cost estimates based on a more detailed engineering design package. As indicated above, there were no notable changes in scope between the time when the Project Team prepared the preliminary cost estimate and when the Performance Partner and Alliance Partner prepared and submitted their estimates.

1. SDG&E’s Preliminary Mechanical Construction Contractor Estimate (confidential): SDG&E’s preliminary cost estimate for construction was [REDACTED].
2. Mechanical Construction Contractor’s Target Price Estimate (confidential): The Mechanical Construction Contractor’s cost estimate was [REDACTED], which was [REDACTED] than SDG&E’s preliminary cost estimate for construction.
3. SDG&E’s Preliminary Electrical Contractor Estimate (confidential): SDG&E’s preliminary cost estimate for electrical construction was [REDACTED].
4. Electrical Contractor’s Estimate (confidential): The Electrical Contractor’s estimate was [REDACTED], which was [REDACTED] than SDG&E’s preliminary cost estimate.

B. Construction Schedule

Table 3: Construction Timeline

Construction Start Date	04/23/2018
Construction Completion Date	01/09/2019
Days on Site	32
NOP Date	07/23/2019

Final Report for Line 1601 Valve Enhancement Project

C. Changes During Construction

SDG&E successfully mitigated field conditions during construction in a manner that minimized potential impacts on project scope, cost, and schedule. As a result, these conditions did not result in any notable change orders.

Final Report for Line 1601 Valve Enhancement Project

Figure 3: New Clamp On Flowmeter



Final Report for Line 1601 Valve Enhancement Project

D. Commissioning and Site Restoration

Commissioning activities included site restoration, final inspections, and placement of the flowmeter into service. During this stage, SDG&E successfully performed site acceptance testing and conducted point-to-point verification with Gas Control personnel for the new flowmeter, and transferred ownership of the new equipment to Field Operations. Closeout activities included development of final drawings, the reconciliation package, and updates to company recordkeeping systems to reflect the completed scope of work. The site was commissioned on July 23, 2019, as summarized in Table 3.

IV. PROJECT COSTS

A. Cost Avoidance Actions

SDG&E exercised due diligence in the design, planning, and construction activities for this project to minimize or avoid costs when prudent to do so. As discussed above, the Project Team reviewed existing records, communicated with external stakeholders, and conducted a site walk to incorporate the site conditions in the project plan and design and captured efficiencies in the project design and project implementation plan when possible. The Project Team located the flowmeter in an existing SDG&E facility that already had communication equipment avoiding costs compared to other potential locations where new communications equipment would be necessary.

B. Cost Estimates

Based on the preliminary design, once the preliminary project scope was confirmed and engineering, design, and planning activities were underway, SDG&E prepared an estimate of the Direct Costs of the Project in the amount of \$459,899. The Project Team considered the conditions known at the time to prepare the preliminary Direct Cost estimate. This estimate reflects the projected Labor, Material, and Services costs anticipated to be incurred to execute the Project, based on initial design plans.

SDG&E estimated Indirect Costs of the Project based on the estimated Direct Costs and other project-related variables.

C. Actual Direct and Indirect Costs

Actual Direct Costs reflect the Labor, Material, and Services costs incurred to execute the Project. Actual Indirect Costs reflect costs for incremental overhead loaders in accordance with Company overhead allocation policies. The total loaded cost of the Project is \$822,943.

Final Report for Line 1601 Valve Enhancement Project

Table 4: Estimated and Actual Direct Costs and Variances³

Direct Costs (\$)	Estimate	Actuals	Delta Over/(Under)
Company Labor	65,263	58,945	(6,318)
Materials	48,895	65,834	16,939
Mechanical Construction Contractor	134,693	225,666	90,973
Electrical Contractor	35,013	31,830	(3,183)
Construction Management & Support	9,900	72,062	62,162
Environmental	59,665	15,800	(43,865)
Engineering & Design	26,284	143,319	117,035
Project Management & Services	32,138	7,083	(25,055)
ROW & Permits	6,239	-	(6,239)
GMA	41,809	24,855	(16,954)
Total Direct Costs	459,899	645,394	185,495

Table 5: Estimated and Actual Indirect Costs, Total Costs, and Variances⁴

Indirect Costs/Total Costs (\$)	Estimate	Actuals	Delta Over/(Under)
Overheads	130,904	130,303	(601)
AFUDC	137,633	40,318	(97,315)
Property Taxes	-	6,927	6,927
Total Indirect Costs	268,537	177,549	(90,988)
Total Direct Costs	459,899	645,394	185,495
Total Loaded Costs	728,436	822,943	94,507

³ Values may not add to total due to rounding.

⁴ Ibid.

V. CONCLUSION

SDG&E enhanced the safety of its integrated natural gas system by prudently executing the Line 1601 Valve Enhancement Project. Through this Valve Enhancement Project, SDG&E successfully installed a new flowmeter to enhance operational flexibility and diagnosis of its natural gas transmission system of Line 1601 in the City of Carlsbad. The total loaded cost of the Project is \$822,943.

SDG&E executed this project prudently through designing and executing the project to support achievement of Valve Enhancement Plan isolation objectives and installing a flowmeter on a portion of Line 1601.

SDG&E engaged in prudent cost avoidance efforts to complete this safety enhancement at a reasonable cost by carefully planning and coordinating construction activities to maximize efficiencies and reduce customer and community impacts.

End of Line 1601 Valve Enhancement Project Final Report