

Modernization of Distribution System & Integration of Distributed Generation and Storage



A  Sempra Energy utility®



Presentation for EPIC Symposium
December 1, 2016
Sacramento, CA

Modernization of Distribution System & Integration of Distributed Generation and Storage



Presented jointly by:

Zoltan Kertay – *Project Technical Lead*

Kirsten Petersen – *Engineering Support Staff,
System Protection & Control Engineering*

SDG&E EPIC Communication Infrastructure Projects



- Visualization and Situational Awareness Demonstrations (EPIC-1 Project)
 - Focus: Presentation of data to system operators in a way that enhances situational awareness
- Smart Grid Architecture Demonstrations (EPIC-1 Project)
 - Focus: Communications standards for integration of feeder equipment and DER into networked automation
- Modernization of Distribution System and Integration of Distributed Generation and Storage (EPIC-2 Project)
 - Focus: New communication standards for substation network
- Monitoring, Communication, and Control Infrastructure for Power System Modernization (EPIC-2 Project)
 - Focus: Open Field Message Bus (presented at last EPIC symposium)

Project Objectives



- Pre-commercial demonstration of distribution system modernization solutions, with main focus on new substation protection systems, integration, control and monitoring.
 - Develop more knowledge of IEC 61850 to aid in decision making on whether or not SDG&E should pursue the IEC 61850 standard on a commercial basis and what the requirements for doing so would be.
 - Address the IEC 61850 interoperability of merging units, process bus and station bus within the substation yard.

Project Team

- Internal groups/resources
 - Technology and System Demonstrations, Distributed Energy Resources Section (Project Technical Lead and DER engineering support staff)
 - System Protection & Control Engineering (Support staff)
 - Integrated Test Facility (ITF)
- External
 - Engineering consulting firm
 - Competitively procured contractor



Project Approach



- Conduct pilot mock-up and pre-commercial demonstration of an IEC 61850-conformant substation network
 - May take place at SDG&E's Integrated Test Facility (ITF) or a similar facility.
- Assess the pros, cons, and benefits of using IEC 61850 by examining a variety of use cases

Project Work Flow

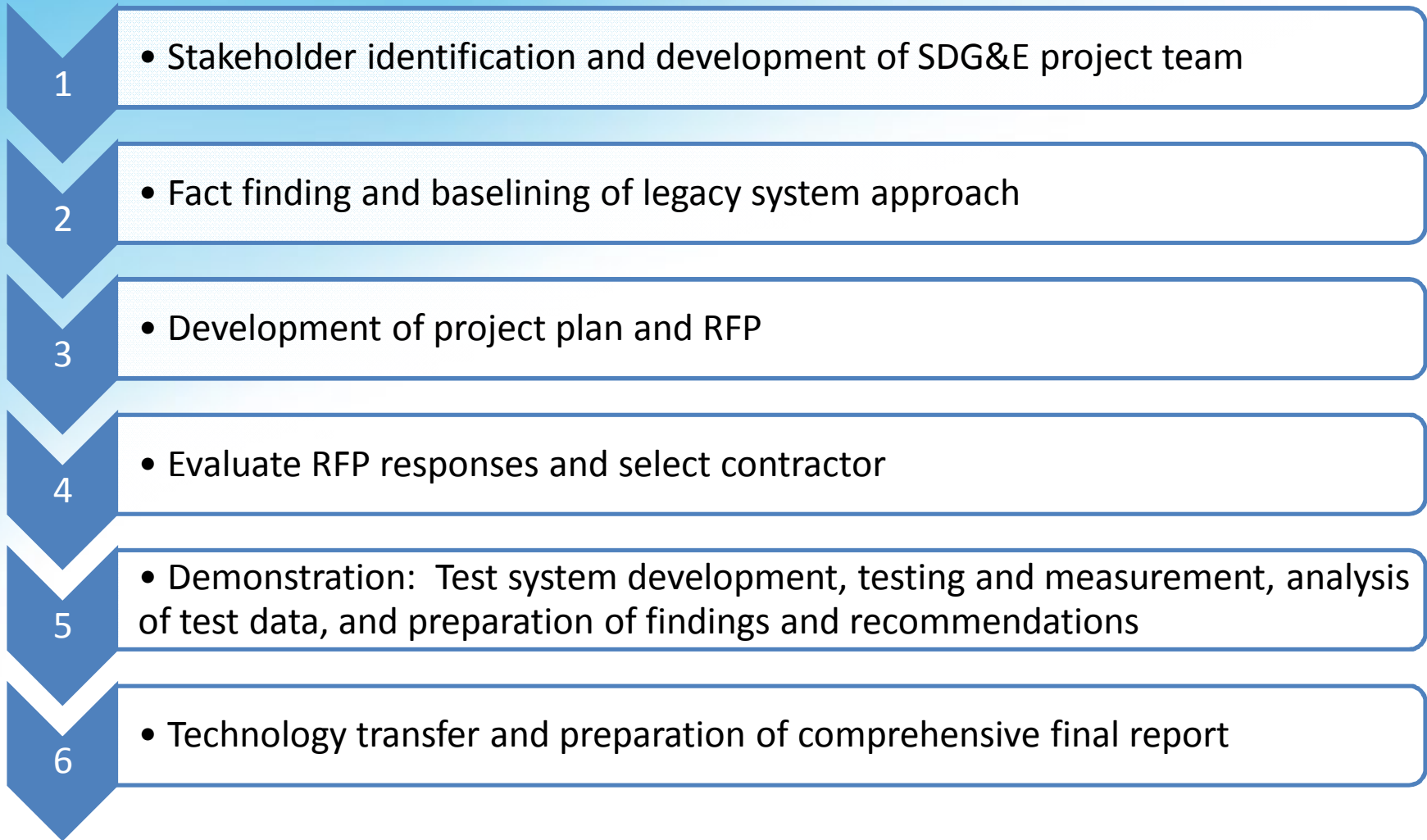

Proposed Use Cases



- Control/Communications Cases
 - Integrate digital messaging with analog inputs by using merging units in the substation yard
 - Test broadcast-capability of substation devices using GOOSE and measured values to protective devices
- Protection Cases
 - Demonstrate IEC 61850 integration with legacy equipment present at existing substations
 - Test the interoperability of merging units with relays for 61850-9-2 sampled values
 - *Are vendor solutions configurable?*
 - *Are solutions compatible with devices made by other vendors?*

Comparison of Legacy and IEC 61850 System

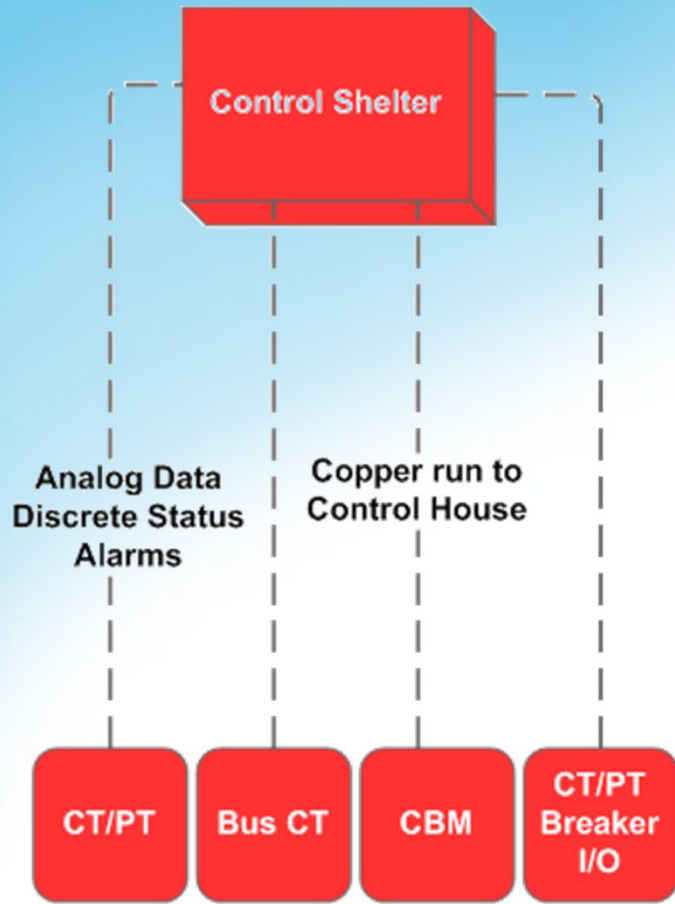

Legacy Analog System

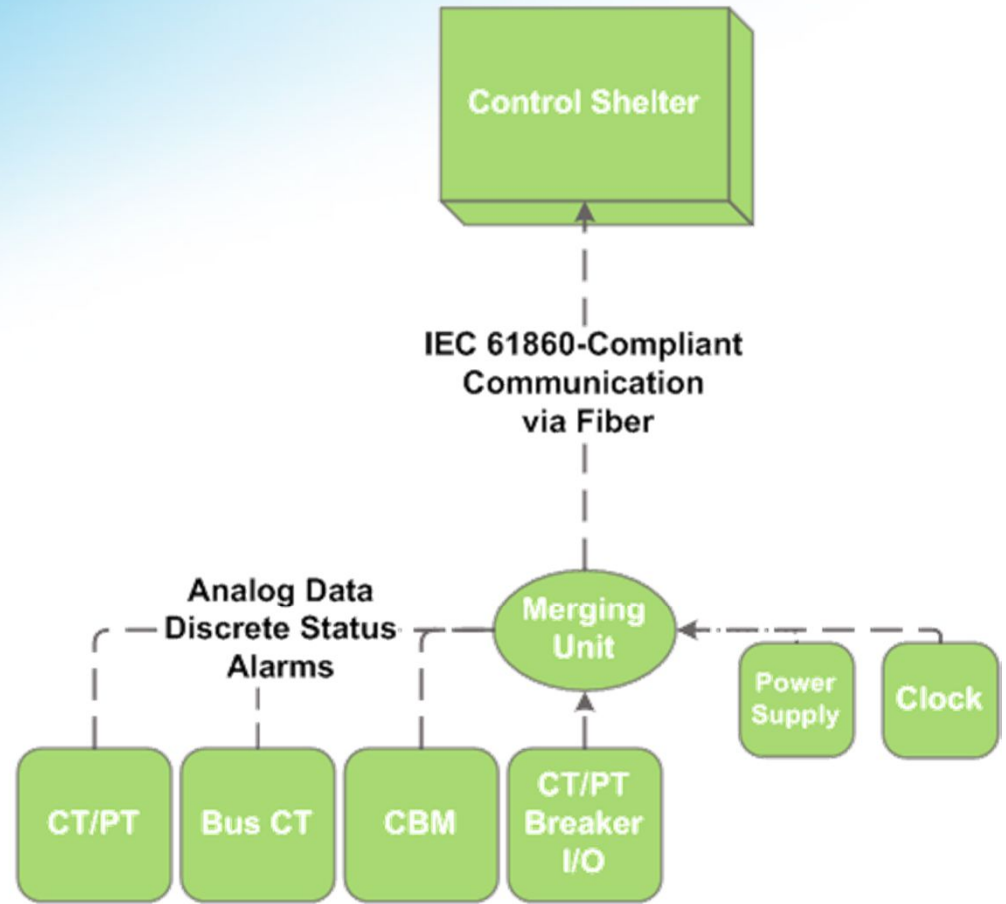

IEC 61850 Compliant System

Our Challenges



© 2016 San Diego Gas & Electric Company

- 
- Interoperability of merging units / vendor-proprietary restrictions
 - Developing SDG&E subject matter experts / experience with IEC 61850

Deliverables

- Comprehensive final report describing work done and results available
 - For use by SDG&E stakeholders in road mapping SDG&E's future plans in this area
 - For delivery to CPUC to be made available to other prospective users



Current Status



- ✓ Project plan drafted
- ✓ Internal SDG&E project team formed and activities launched
- ✓ Project plan to be finalized in December 2016
- ✓ Request for Proposals to be issued by January 2017
- Next step: Competitive procurement of prime contractor in early 2017

Contact Us



For questions or interest in this project please contact:

- EPIC Program Manager
Frank Goodman
fgoodman@semprautilities.com

- Project Technical Lead
Zoltan Kertay
zkertay@seucontractor.com

